

**TECHNICAL MANUAL**

**OPERATOR'S, ORGANIZATIONAL, DIRECT SUPPORT,  
GENERAL SUPPORT, AND DEPOT  
MAINTENANCE MANUAL  
(INCLUDING REPAIR PARTS INFORMATION AND  
SUPPLEMENTAL MAINTENANCE INSTRUCTIONS)  
FOR  
CRANE, TRUCK MOUNTED,  
HYDRAULIC,  
25 TON (CCE)  
HARNISCHFEGER MODEL MT-250  
NON-WINTERIZED  
NSN 3810-00-018-2021  
HARNISCHFEGER MODEL MT-250,  
WINTERIZED  
NSN 3810-00-018-2007**

**This copy is a reprint which includes current  
pages from Changes 1 through 3.**

---

**HEADQUARTERS, DEPARTMENT OF THE ARMY  
15 SEPTEMBER 1980**

**WARNING**

A hydraulic crane is **NOT** like a lattice boom friction crane in one very important way. In most cases, the safe lifting capacity of a lattice boom crane is based **ON THE WEIGHT NEEDED TO TIP THE MACHINE**. Therefore, operators of friction machines sometimes depend on signs that the machine might tip to warn them of impending danger.

This is a very dangerous thing to do with a hydraulic crane. Hydraulic crane ratings are based **ON THE STRENGTH OF THE MATERIAL OF THE BOOM** (and other components). Therefore, the hydraulic crane operator who waits for signs of tipping to warn him of an overloaded condition **WILL OFTEN BEND THE BOOM OR CAUSE SEVERE DAMAGE TO HIS MACHINE BEFORE ANY SIGNS OF TIPPING OCCUR**.

**OPERATORS OF ALL HYDRAULIC CRANES MUST BE GUIDED SOLELY BY THE RATING PLATE RECOMMENDATIONS CONCERNING LOAD, BOOM LENGTH, BOOM RADIUS**, and other factors listed on the rating plate, such as outrigger position and level terrain.

CHANGE }  
NO. 3 }

HEADQUARTERS  
DEPARTMENT OF THE ARMY  
Washington, D.C., 10 October 1986

**TECHNICAL MANUAL**

**OPERATOR'S, ORGANIZATIONAL, DIRECT SUPPORT, GENERAL SUPPORT,  
AND DEPOT MAINTENANCE MANUAL (INCLUDING REPAIR PARTS  
INFORMATION AND SUPPLEMENTAL MAINTENANCE INSTRUCTIONS) FOR**

**CRANE, TRUCK MOUNTED, HYDRAULIC, 25 TON (CCE)**

**HARNISCHFEGER MODEL MT-250, NON-WINTERIZED**

**NSN 3810-00-018-2021**

**HARNISCHFEGER MODEL MT-250, WINTERIZED**

**NSN 3810-00-018-2007**

TM 5-3810-293-14&P-1, 15 September 1980, is changed as follows:

1. Part Three Crane Repair Parts Manual, has been replaced by TM 5381029320P, Organizational Maintenance Repair Parts and Special Tools Lists and TM 5381029334P, Direct Support and General Support Maintenance Repair Parts and Special Tools Lists.
2. Remove old pages and insert new pages as indicated below.

*Remove Pages*

Pages 3-2-11 through 3-2-31/(3-2-32 blank)  
APPENDIX 2-A

*Insert Pages*

Pages 3-2-11 through 3-2-26 APPENDIX 2-A

3. File this change sheet in front of the publication for reference purposes.

By Order of the Secretary of the Army:

JOHN A. WICKHAM, JR.  
*General, United States Army*  
*Chief of Staff*

Official:

R. L. DILWORTH  
*Brigadier General, United States Army*  
*The Adjutant General*

Distribution:

To be distributed in accordance with DA Form 1225AR, (Blocks 571, 572, 573), Operator's, Organizational, Direct Support, General Support and Depot Maintenance requirements for Cranes, Truck Mounted, Hydraulic, 25-T, Model MT-250.

CHANGE }  
No. 2 }

HEADQUARTERS  
DEPARTMENT OF THE ARMY  
WASHINGTON, D.C., 12 October 1983

**Operator, Organizational, Direct Support  
General Support and Depot Maintenance Manual  
(Including Repair Parts Information and Supplemental Maintenance Instructions)  
For  
CRANE, TRUCK MOUNTED, HYDRAULIC,  
25 TON (CCE)  
HARNISCHFEGER MODEL MT-250, NON-WINTERIZED  
(NSN 3810-00-018-2021)  
HARNISCHFEGER MODEL MT-250, WINTERIZED  
(NSN 3810-00-018-2007)**

TM 5-3810-293-14&P-1, 15 September 1980, is changed as follows:

1. Change Sheet for Change 1, following Washington, DC, insert date, "30 June 1983".
2. File this change sheet in front of publication for reference purposes.

By Order of the Secretary of the Army:

Official:

ROBERT M. JOYCE  
*Major General, United States Army  
The Adjutant General*

JOHN A. WICKHAM, JR.  
*General, United States Army  
Chief of Staff*

**DISTRIBUTION:**

To be distributed in accordance with DA Form 12-25B, Operator's Maintenance requirements for Cranes: Truck Mounted.

CHANGE  
NO. 1

HEADQUARTERS  
DEPARTMENT OF THE ARMY  
WASHINGTON, DC, 30 June 1983

**OPERATOR, ORGANIZATIONAL, DIRECT SUPPORT,  
GENERAL SUPPORT AND DEPOT  
MAINTENANCE MANUAL  
(INCLUDING REPAIR PARTS INFORMATION AND  
SUPPLEMENTAL MAINTENANCE INSTRUCTIONS)  
FOR  
CRANE, TRUCK MOUNTED, HYDRAULIC,  
25 TON (CCE)  
HARNISCHFEGER MODEL MT-250, NON-WINTERIZED  
(NSN 3810-00-018-2021)  
HARNISCHFEGER MODEL MT-250, WINTERIZED  
(NSN 3810-00-018-2007)**

TM 5-3810-293-14&P-1, 15 September 1980 is changed as follows:

1. Remove old pages and insert new pages as indicated below.
2. New or changed material is indicated by a vertical bar in the margin of the page.
3. Added or revised illustrations are indicated by a vertical bar adjacent to the illustration identification number.

*Remove pages*

i/(ii blank)  
1-2-5 and 1-2-6  
1-2-21 and 1-2-22  
1-2-22.1/(1-2-22.2 blank)  
1-2-25 through 1-2-27/(1-2-28 blank)  
2-1-3 and 2-1-4

*Insert pages*

i and ii  
1-2-5 and 1-2-6  
1-2-21 and 1-2-22  
  
1-2-25 through 1-2-27/(1-2-28 blank)  
2-1-3 and 2-1-4

File this change in the front of the publication for reference purposes.

By Order of the Secretary of the Army:

E. C. MEYER  
*General, United States Army*  
*Chief of Staff*

Official:

ROBERT M. JOYCE  
*Major General, United States Army*  
*The Adjutant General*

Distribution:

To be distributed in accordance with DA Form 1225B, Operator, Organizational, Direct Support, General Support and Depot Maintenance Manual for Crane, Truck Mounted, Hydraulic, 25-Ton (CCE) Harnischfeger Model MT-250.

*This Manual contains copyrighted material.*

*Published with permission of Dana Corporation, Spicer Transmission Division, Toledo, Ohio and Rockwell International, Automotive Operations Troy, Michigan.*

TECHNICAL MANUAL }  
No. 5-3810-293-14&P-1J }

**HEADQUARTERS  
DEPARTMENT OF THE ARMY  
WASHINGTON, DC, 15 September 1980**

**OPERATOR, ORGANIZATIONAL, DIRECT SUPPORT  
GENERAL SUPPORT AND DEPOT MAINTENANCE MANUAL  
(INCLUDING REPAIR PARTS INFORMATION AND SUPPLEMENTAL MAINTENANCE INSTRUCTIONS)  
FOR  
CRANE, TRUCK MOUNTED, HYDRAULIC,  
25 TON (CCE)  
HARNISCHFEGER MODEL MT-250. NON-WINTERIZED  
(NSN 3810-00-018-2021)  
HARNISCHFEGER MODEL MT-250, WINTERIZED  
(NSN 3810-00-018-2007)**

**REPORTING ERRORS**

You can help improve this publication. If you find any mistakes, or if you know of a way to improve the procedures, please let us know. Mail your letter, DA Form 2028 (Recommended Changes to Publications and Blank Forms), or DA Form 20282 located in back of this manual direct to: US Army Tank Automotive Command, ATTN: DRSTAMPB, Warren, MI 48090. A reply will be furnished to you.

PART ONE. CRANE OPERATOR'S MANUAL .....1-1-1  
TWO WEIGHLOAD AUTOMATIC SAFE LOAD INDICATOR .....2-1-1  
THREE SUPPLEMENTAL MAINTENANCE AND REPAIR PARTS INSTRUCTIONS .....3-1-1

NOTE: Refer to TM 5-3810-293-14&P-2 for Crane Shop Manual, Crane Repair Parts Manual, Front Axle Transmissions, and Winches

NOTE: Refer to TM 5-3810293-14&P-3 for Engine Operator's Manual, Engine Service Manual, Engine Parts Catalog

**This technical manual an authentication of the manufacturer's commercial literature and does not conform with the format and content specified In AR 310-3, Military Publications. This technical manual does, however, contain available information that is essential to the operation and maintenance of the equipment.**



**PART ONE**  
**CRANE OPERATOR'S MANUAL**

TABLE OF CONTENTS

**SECTION I INTRODUCTION**

Scope.....1-1-1  
 General Information.....1-1-1  
 Safety.....1-1-1  
 Serial Number Location.....1-1-1  
 Warranty.....1-1-1  
 Description.....1-1-2  
 Tabulated Data.....1-1-2  
     Dimensions and Transportation Data.....1-1-2  
     Liquid Capacities.....1-1-4  
     Light Bulbs.....1-1-4  
     Filter Elements.....1-1-4

**SECTION II CONTROLS AND OPERATION**

Carrier Control Identification.....1-2-1  
 Carrier Operation.....1-2-5  
 Outrigger Operation.....1-2-6  
 Upper Control Identification.....1-2-8  
 Crane Operation.....1-2-12  
 Carrier Remote Controls.....1-2-17  
     General.....1-2-17  
     Control Identification.....1-2-17  
     Operation.....1-2-17  
 Hand Signals.....1-2-18  
 Operation Under Unusual Conditions.....1-2-18  
 Installing Rope on Drums.....1-2-21  
 Reeving.....1-2-22  
 Jib Attachment.....1-2-23  
 Manual Fly Section.....1-2-26  
 Counterweight.....1-2-27  
 Installation and Operation of Self Powered Pile Driver Hammer (NSN 3895-00-014-0583).....1-2-27  
 Towing.....1-2-27

**SECTION III LUBRICATION**

General.....1-3-1  
 Lubricant Specifications.....1-3-1

**SECTION IV PREVENTIVE MAINTENANCE**

General.....1-4-1  
 Using the Suggested Check Sheet.....1-4-1

**SECTION V MACHINE STORAGE**

General.....1-5-1  
 General.....1-5-1  
 Preparation for Short Term Storage.....1-5-1  
 Preparation for Long Term Storage.....1-5-2  
 Removal from Short Term Storage.....1-5-4  
 Removal from Long Term Storage.....1-5-5

## SECTION I

## INTRODUCTION

## SCOPE

This manual provides operating instructions and information concerning routine lubrication and service as required for the most efficient use of this machine.

Overhaul and repair information is provided in a separate shop manual. Overhaul information on the engine and certain other purchased components is not included in the shop manual, since the original manufacturer's manuals are both authoritative and complete.

## GENERAL INFORMATION

The information, specifications and illustrations in this publication are based on the information in effect at the time of approval for printing. This publication is revised and reprinted periodically. It is recommended that the user contact the Harnischfeger Technical Publications Department for information on the latest revisions. The Harnischfeger Corporation reserves the right to make changes to this manual at any time without prior notice or obligation.

Any part numbers which appear in this manual are for reference only, refer to the P&H Replacement Parts Manual when ordering parts.

## SAFETY

A separate publication, Catalog 221, Safe Operating Practices, is furnished with each machine. It is most important that operators and maintenance personnel read and be familiar with the information in Catalog 221 and this manual before operating or servicing this machine, both for personal protection and for the safety of other workmen and bystanders.

Additional copies of Catalog 221 are available, in reasonable quantities, to Owners of P&H hydraulic

excavators and cranes at no cost. Submit such requests to the Harnischfeger Technical Publications Department.

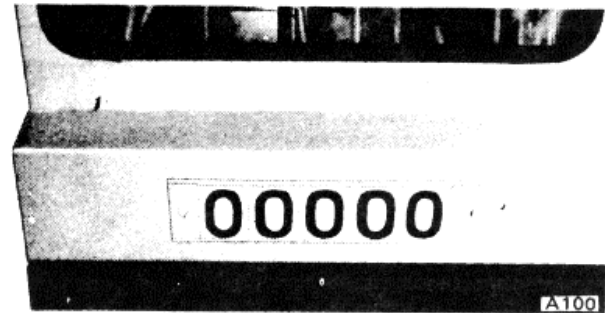

*Figure 1-1. Machine Serial Number*

## SERIAL NUMBER LOCATION

Figure 1-1 illustrates the machine serial number which is located on the lower front side of the operator's cab. Always indicate the machine serial number in all correspondence to properly identify the machine, and to ensure that the correct parts are obtained, when ordered.

## WARRANTY

The terms under which this machine is guaranteed are clearly defined under the warranty which accompanies every P&H product. This warranty, while generous, will be voided if the machine is operated with loads in excess of the rating plate maximums, under unsafe operating conditions, or with accessories or attachments not designed and furnished, or approved by the Harnischfeger Corporation. Modifications made upon the machine which will affect its operation or capacity will void the warranty.

**SECTION I**

**INTRODUCTION**

**DESCRIPTION**

This truck crane is a fully hydraulic machine. All work functions are performed by fluid power. Hydraulic cylinders are used to raise or lower and extend or retract the boom; hydraulic winches raise or lower the load on the main hoist and jib lines; a hydraulic motor swings (rotates) the upper of the machine on the carrier.

The carrier engine serves as the power supply for both the upper and lower. A pump drive, mounted at the front of the engine drives the hydraulic pumps which provide the hydraulic power for the upper. Hydraulic fluid under pressure is delivered through a swivel to the control valves in the upper. When the operator engages the controls in the operator's cab, the control valves direct the fluid to the boom cylinders, swing motor, and winch motors.

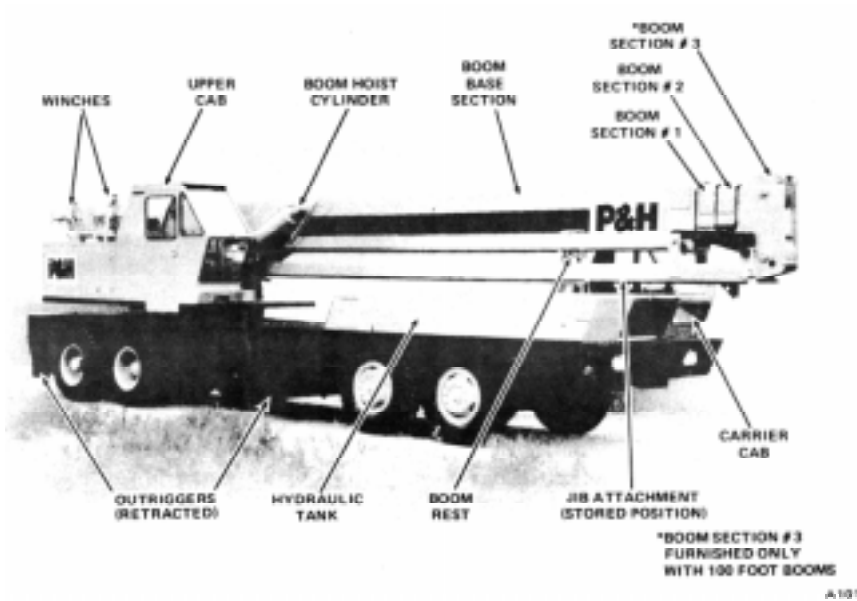

Figure 1-2. Crane Terminology

**TABULATED DATA**

**DIMENSIONS AND TRANSPORTATION DATA**

Overall length, with boom in travel position .....	38'-1-3/8" (11.62 m)
Overall length, without boom .....	33'-1-1/2" (10.10 m)
Overall width .....	8'-" (2.44 m)
Overall height .....	1'-0" (3.00 m)
Ground clearance .....	0'-10-1/2" (0.27 m)
Gross vehicle weight, with main and auxiliary winches, jib, bottom block, 4,500 lb (2,041 kg) counterweight, & 1/2 tank of fuel.....	80' Boom (24.38 m) 64,400 lbs. (29,211 kg)
	100' Boom (30.48 m) 65,300 lbs. (29,620 kg)
Weight Distribution	
Front axle.....	80' Boom 26,600 lbs (12,066 kg)
	100' Boom 27,200 lbs (12,338 kg)
Rear axle .....	80' Boom 37,800 lbs (17,146 kg)
	100' Boom 38,100 lbs (17,282 kg)

SECTION I

INTRODUCTION

MAIN WINCH DATA P&H PART NO. 923P5-FIG. 1									
MODEL: P&H #10-1									
Rope Size:		9/16" Dia. (14.3mm)			Pressure:		3000 P.S.I. (206 Bars)		
Drum Dia.:		10-11/16" (271.5mm)			Flow:		55 G.P.M. (208 l/min)		
Drum Pitch Dia.:		11-1/4" (285.6mm)			Drum Torque "Up" Low SPD.:		65,000 in. lbs. (749 m-kg)		
Drum Width:		14" (355.6mm)			Drum Torque "Up" High SPD.:		29,000 in. lbs. (334 m-kg)		
Flange O.D.:		19" (482.6mm)			Drum RPM "Up" Low SPD.:		46		
P.D. to rope dia. ratio:		20:1			Drum RPM "Up" High SPD.:		109		
LOW SPEED					HIGH SPEED				
Layer	Rope Pitch Dia.-In. (mm)	Line Pull "Up"-Lbs. (kg)	Full Load Line SPD. "Up"-FPM (m/min)	No Load Line SPD. "Up"-FPM (m/min)	Line Pull "Up"-Lbs. (kg)	Full Load Line SPD. "Up"-FPM (m/min)	No Load Line SPD. "Up"-FPM (m/min)	Drum Capacity Ft./Layer (m/Layer)	Accum. Drum Capacity Ft. (m)
1	11-1/4 (285.7)	11,600 (5,262)	136 (41.45)	155 (47.24)	5,200 (2,359)	320 (97.54)	365 (111.25)	67 (20.42)	67 (20.42)
2	12-3/8 (314.3)	10,500 (4,763)	150 (45.72)	170 (51.82)	4,700 (2,132)	350 (106.68)	400 (121.92)	76 (23.16)	143 (43.59)
3	13-1/2 (342.9)	9,600 (4,354)	163 (49.68)	195 (59.44)	4,300 (1,950)	380 (115.82)	435 (132.59)	83 (25.30)	226 (68.88)
4	14-5/8 (371.5)	8,900 (4,037)	175 (53.34)	200 (60.86)	4,000 (1,814)	415 (126.49)	475 (144.78)	90 (27.43)	316 (96.32)
5	15-3/4 (400.0)	8,300 (3,765)	190 (57.91)	220 (67.06)	3,700 (1,678)	450 (137.16)	515 (156.97)	97 (29.57)	413 (125.88)
6	16-7/8 (428.6)	7,700 (3,493)	200 (60.96)	230 (70.10)	3,400 (1,542)	480 (146.30)	550 (167.64)	104 (31.70)	517 (157.98)

AUXILIARY WINCH DATA P&H PART NO. 923P5-FIG. 1									
MODEL: P&H #10-1									
Rope Size:		9/16" Dia. (14.3mm)			Pressure:		3000 P.S.I. (206 Bars)		
Drum Dia.:		10-11/16" (271.5mm)			Flow:		55 G.P.M. (208 l/min)		
Drum Pitch Dia.:		11-1/4" (285.6mm)			Drum Torque "Up" Low SPD.:		65,000 in. lbs. (749 m-kg)		
Drum Width:		14" (355.6mm)			Drum Torque "Up" High SPD.:		29,000 in. lbs. (334 m-kg)		
Flange O.D.:		19" (482.6mm)			Drum RPM "Up" Low SPD.:		46		
P.D. to rope dia. ratio:		20:1			Drum RPM "Up" High SPD.:		109		
LOW SPEED					HIGH SPEED				
Layer	Rope Pitch Dia.-In. (mm)	Line Pull "Up"-Lbs. (kg)	Full Load Line SPD. "Up"-FPM (m/min)	No Load Line SPD. "Up"-FPM (m/min)	Line Pull "Up"-Lbs. (kg)	Full Load Line SPD. "Up"-FPM (m/min)	No Load Line SPD. "Up"-FPM (m/min)	Drum Capacity Ft./Layer (m/Layer)	Accum. Drum Capacity Ft. (m)
1	11-1/4 (285.7)	11,600 (5,262)	136 (41.45)	155 (47.24)	5,200 (2,359)	320 (97.54)	365 (111.25)	67 (20.42)	67 (20.42)
2	12-3/8 (314.3)	10,500 (4,763)	150 (45.72)	170 (51.82)	4,700 (2,132)	350 (106.68)	400 (121.92)	76 (23.16)	143 (43.59)
3	13-1/2 (342.9)	9,600 (4,354)	163 (49.68)	195 (59.44)	4,300 (1,950)	380 (115.82)	435 (132.59)	83 (25.30)	226 (68.88)
4	14-5/8 (371.5)	8,900 (4,037)	175 (53.34)	200 (60.86)	4,000 (1,814)	415 (126.49)	475 (144.78)	90 (27.43)	316 (96.32)
5	15-3/4 (400.0)	8,300 (3,765)	190 (57.91)	220 (67.06)	3,700 (1,678)	450 (137.16)	515 (156.97)	97 (29.57)	413 (125.88)
6	16-7/8 (428.6)	7,700 (3,493)	200 (60.96)	230 (70.10)	3,400 (1,542)	480 (146.30)	550 (167.64)	104 (31.70)	517 (157.98)

**SECTION I**

**INTRODUCTION**

**LIQUID CAPACITIES (U.S UNITS)**

Fuel Tank .....	70 gallons (265 l)
Engine Cooling System:	
Detroit Diesel 6V53N .....	40 quarts (37.8 l)
Cummins C190 .....	31-1/2 quarts (29.8 l)
Detroit Diesel 6-71 .....	48 quarts (45.4 l)
Cummins NHF 240 .....	46 quarts (43.5 l)
Engine Lube Oil, including filter(s):	
Detroit Diesel 6V53N .....	18-1/2 quarts (17.5 l)
Cummins C190 .....	18-1/2 quarts (17.5 l)
Detroit Diesel 6-71 .....	20 quarts (18.9 l)
Cummins NHF 240 .....	22 quarts (20.8 l)
Main Transmission Oil:	
Spicer 6352 .....	17 pints (8.0 l)
Fuller 5CW65T .....	24 pints (11.4 l)
Fuller T905F .....	22 pints (10.4 l)
Auxiliary Transmission Oil:	
Spicer 8031C .....	13 pints (6.2 l)
Spicer R 8341 E .....	13 pints (6.2 l)
Fuller 3K65 .....	12 pints (5.7 l)
Rear Axles Rockwell SSHD:	
Front 32 pints (15.1 l)	
Rear 28 pints (13.2 l)	
Interaxle Differential .....	2 pints (0.9 l)
Rear Axles Rockwell SRHD:	
Front 37 pints (17.5 l)	
Rear 36 pints (17.0 l)	
Interaxle Differential .....	2 pints (0.9 l)
Power Take-Off:	
Dana .....	6 quarts (5.7 l)
Cotta .....	3-1/2 quarts (3.3 l)
Hydraulic Oil Reservoir .....	200 gallons (757 l)
Winch Planetary Housings (each) .....	2 quarts (1.9 l)
Swing Reducer Housing .....	7 quarts (6.6 l)
Steering Gear .....	2-1/2 quarts (2.4 l)

**LIGHT BULBS**

LOCATION	*NUMBER
Headlights-High Beam	5001
Low Beam	4000
Stop/Tail Lights	1157
Clearance Lights	67
Directional Signal Front	1157
Rear	1157
Indicator	53
Hazard Warning Indicator	53
Low Air Pressure Light	53
Upper Ignition Indicator Light	53
Instrument Lights	57
Dome Light	1141
License Plate Light	1157
Identification Lights	67
Outrigger Indicators-Master Switch	53
Safety Lock	53
*USASI Standard	

LOCATION	*NUMBER
Engine Warning Indicator	1893
High Beam Indicator	53
Ignition Indicator	53
Drum Turn Indicators	1893

**FILTER ELEMENTS**

LOCATION	VENDOR NUMBER
Engine Oil	AC PF-132
Fuel Strainer	AC T-815
Fuel Filter	AC TP816
Air Cleaner	Farr P-32
Hydraulic Oil Filters	Vickers 923070

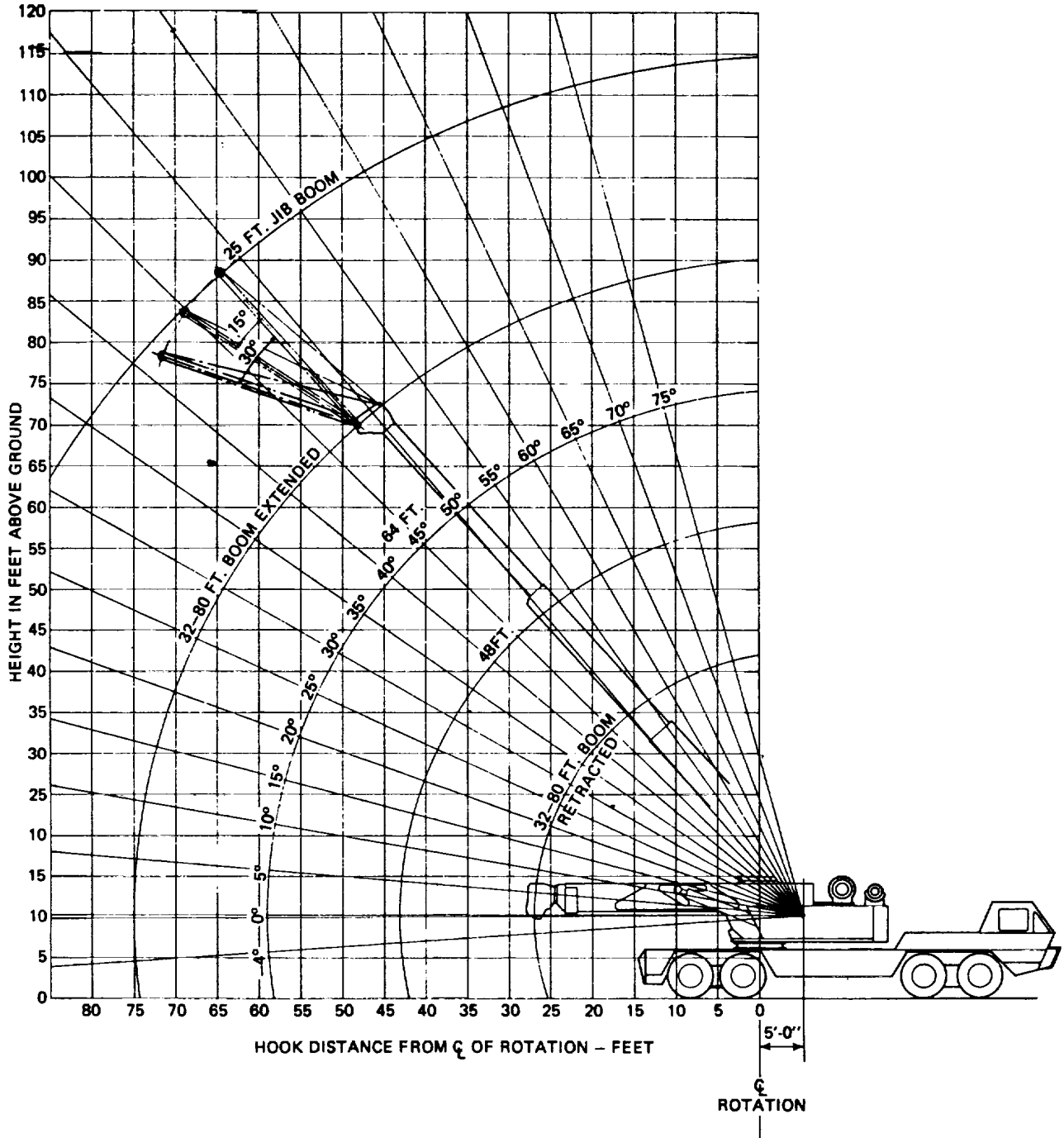

Figure 1-3. Range Diagram - 80' Boom (105X75-A)'

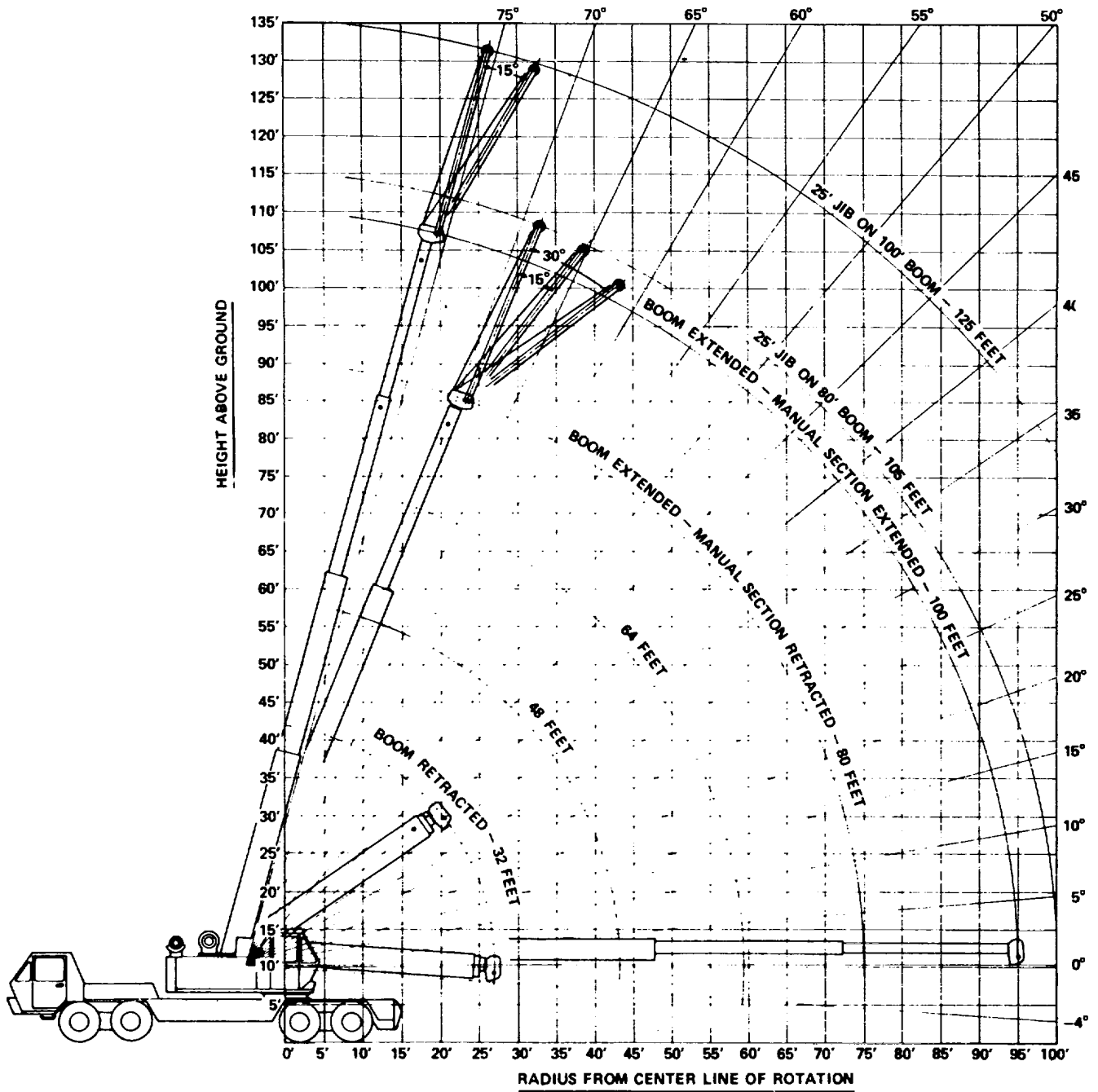

Figure 1-4. Range Diagram-100' Boom (105J683)



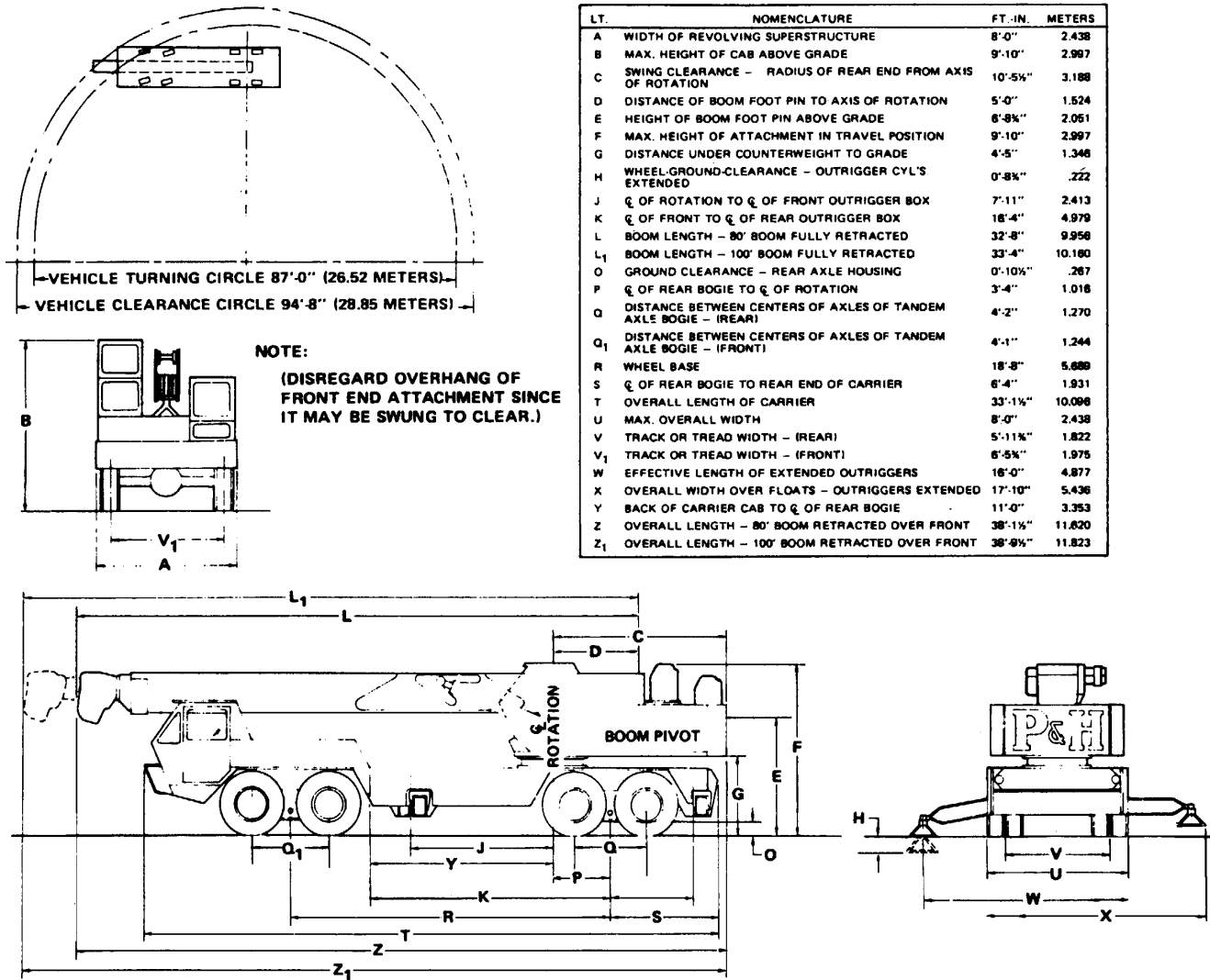

Figure 1-5. Dimensions and Clearance (105J831-B)

## SECTION II CONTROLS AND OPERATION

### CARRIER CONTROL IDENTIFICATION

The instruments and controls in the cab of the carrier are shown in Figure 2-1. The numbers on this figure correspond to the numbers on the following list, which identifies the controls and describes their function.

Before attempting to operate this machine, the operator should study carefully all of the information in this section and in Catalog 221. The operator should become thoroughly familiar with the location and purpose of each control on the machine.

1. **IGNITION INDICATOR.** This lamp is illuminated whenever the ignition switch is in the ON position. If the lamp remains lit after the carrier ignition switch is placed in the OFF position, the upper ignition switch is in the ON position, and must be placed in the OFF position to shut down the ignition system.

2. **HIGHBEAM INDICATOR.** This lamp, when illuminated, indicates that the high headlight beams are on.

3. **VOLTMETER.** The voltmeter measures the voltage produced by the alternator and indicates the condition of the battery. See Figure 2-2 for an explanation of the voltmeter readings.

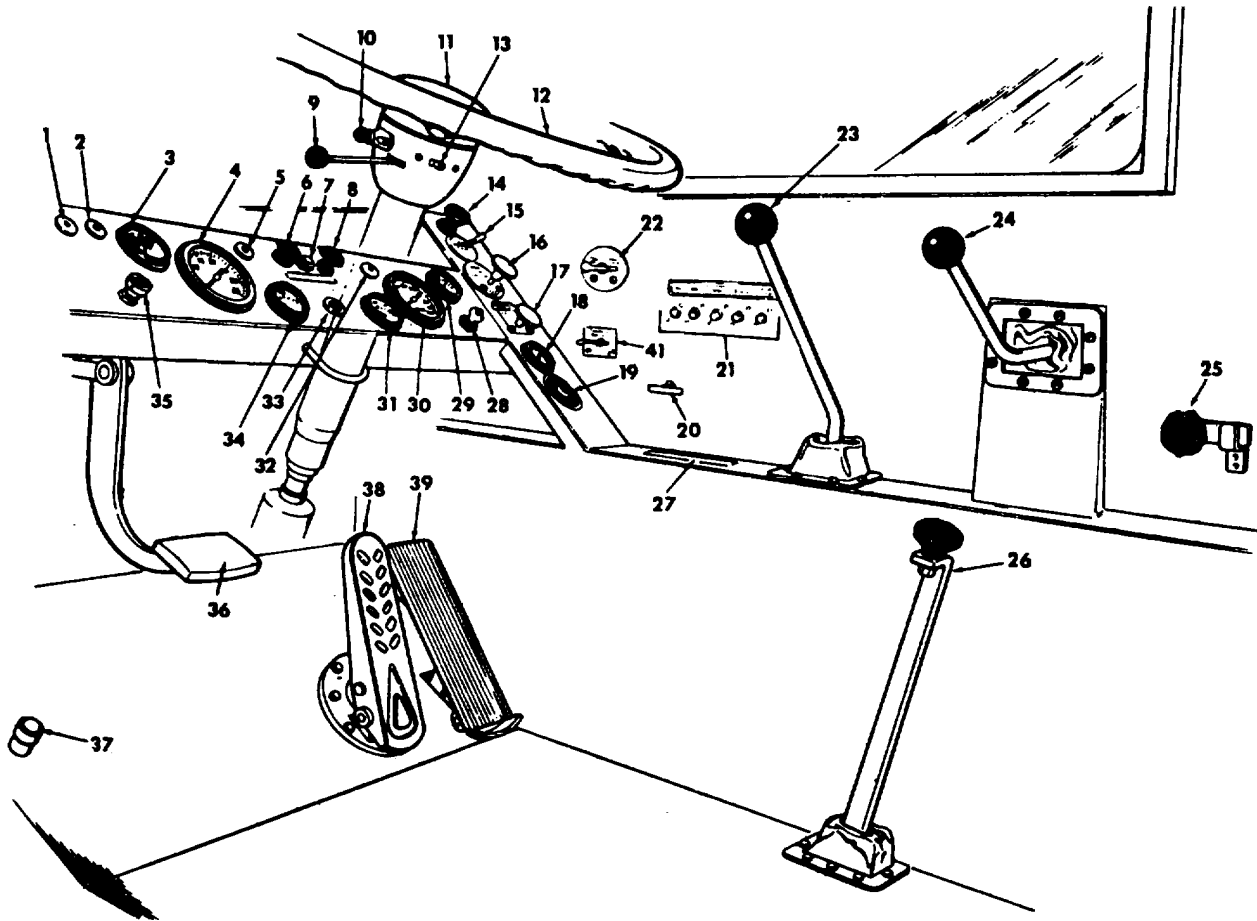

Figure 2-1. Carrier Controls

**Engine not running or running at slow idle.**

**Engine running fast enough to make generator\* produce.**

1 Dead or disconnected battery. Disconnected or badly connected meter.



1 Di: connected meter. Engine could not run with dead or disconnected battery unless circuit was completed around battery.

2 Very low battery charge. Engine might not start.



2 3 When meter pointer stays below 13.3 with the engine running fast enough to operate generator, it shows that generator is not operating or voltage regulator is out of adjustment, or that current being drawn from battery by lights, heater fan, or other load, exceeds generator output.

3 Low battery charge. Constant reading in this area would indicate need for check on generator and voltage regulator.



4 Well-charged battery. This indicates a good battery and also that generator and voltage regulator are operating properly.



4 5 When engine is started, pointer may stay in this area temporarily but should gradually rise above 13.3 as generator reaches normal output.

5 The pointer might remain in this position temporarily when the engine has been stopped after considerable use, due to a "surface charge" in the battery. To get a correct reading, turn on headlights for a few minutes.

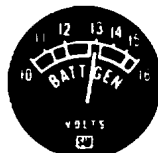

6 7 Under normal conditions, a 12V battery is fully charged at 12.8V. A slightly higher reading may occur under the conditions outlined in No. 5 but, generally speaking, any reading above 12.8 when the engine is stopped is not a true reading.



6 This is the area in which the pointer should be when generator, voltage regulator and battery are all in good condition and working properly.

\*NOTE: The word "generator" refers to both generator and alternator since both require the same instrumentation.



7 When the pointer goes above 15.2, the voltage regulator is set too high or is jammed and continued operation of the engine will burn out the battery.

Figure 2-2. Voltmeter Operation

## SECTION II

## CONTROLS AND OPERATION

4. TACHOMETER-HOURMETER. This gauge indicates the engine speed in revolutions per minute (RPM) and the total number of hours the engine has been run.

5. L. H. DIRECTIONAL SIGNAL INDICATOR

6. HEATER CONTROLS. This switch controls the heater fan. Turn the switch clockwise to energize the heater fan; control the speed of the fan by turning the switch clockwise or counterclockwise as desired.

Figure 2-3 illustrates the heater shut off valve. Turn the valve clockwise to stop the flow of water through the heater, when heat is not required. Turn the valve counterclockwise when heat is desired.

7. ENGINE STOP BUTTON (G.M. ENGINES ONLY).

Depress this button to stop the engine. After the engine has stopped, place the ignition key in the OFF position.

8. DEFOGGER FAN SWITCH. Turn the switch clockwise to energize the defogger fan; control the speed of the fan by turning the switch clockwise or counterclockwise as desired.

9. DIRECTIONAL SIGNAL LEVER. This lever actuates the directional signal lamps at the front and rear of the carrier. Pull the lever toward the operator to actuate the left directional signal; push the lever away from the operator to actuate the right directional signal.

10. HAZARD WARNING INDICATOR. This lamp, when illuminated, indicates that all the directional lights are energized for use as hazard warning lights.

11. HORN BUTTON. Depress this button to sound the carrier horn.

12. STEERING WHEEL.

### NOTE

**If the machine is equipped with a Power Steering/ Outtrigger Selector Valve (item 25), be sure it is pushed in and latched when operating the carrier.**

13. HAZARD WARNING LIGHT SWITCH. Push this switch away from the operator to energize all directional lights for use as hazard warning lights.

14. WINDSHIELD WIPER SWITCH. Turn this switch clockwise to energize the windshield wiper; control the speed of the wiper by turning the switch clockwise or counterclockwise as desired.

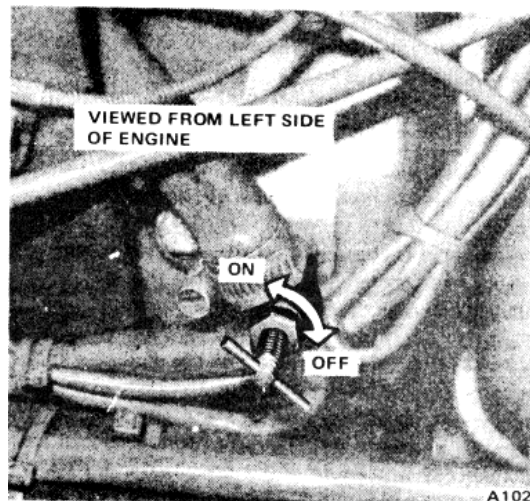

Figure 2-3. Heater Shut-Off Valve

15. DIFFERENTIAL LOCKOUT CONTROL. This lever locks and unlocks the interaxle differential. Place the lever in the LOCK position when approaching or anticipating icy or poor tractive conditions. This will provide maximum axle traction. The interaxle differential can be shifted to the locked position at any vehicle speed, except if the wheels have already lost traction and are spinning.

### CAUTION

**Do not wait until you have lost traction and your wheels are spinning to lock the interaxle differential. This could result in damage to the axles.**

Place the lever in the UNLOCK position after passing adverse conditions. This permits the interaxle differential to compensate for differences in the tire size and give you maximum speed and performance.

### NOTE

**Let up on the accelerator to provide an interruption in torque to the drive train when locking or unlocking the interaxle differential.**

16. EMERGENCY RELEASE VALVE. The emergency release valve provides a means of transferring the isolated emergency air tank to the Maxibrake control valve (item 17) when pressure in the service tanks is lost.

## SECTION II

## CONTROLS AND OPERATION

Push this knob in and pull out the Maxibrake control knob (item 17) if it becomes necessary to use the air in the emergency air tank to release the Maxibrakes.

### **CAUTION**

**The carrier will have no brakes, except the Maxibrakes, which are controlled by the Maxibrake control valve. Never move the carrier farther than is absolutely necessary under these conditions, and avoid steep grades. Make certain that this knob is pulled out at all time during normal operation.**

17. **MAXIBRAKE CONTROL VALVE.** Pull this knob out to release the Maxibrakes. Push this knob in to vent air from the Maxibrake chambers and apply the Maxibrakes. This control will return to the applied position automatically if pressure in the air system drops below 28 psi (1.93 bars).

18. **AIR PRESSURE GAUGE.** This gauge shows the pressure of the air in the air system of the machine. In normal operation, the pressure reading on this gauge should range between 105 and 120 psi (7.28.2 bars).

19. **LOW AIR PRESSURE LIGHT.** When illuminated, this lamp indicates that the pressure in the air system is below the normal safe operating level. Do not operate the machine when this light is lit.

20. **EMERGENCY ENGINE SHUTOFF CONTROL (G. M. ENGINES ONLY).** Pull this handle out if the engine continues to run after the Engine Stop button (item 7) is depressed or if an abnormal condition should arise.

### **NOTE**

**If the engine is shut down using the Emergency Engine Shutoff Control, the butterfly valve in the intake manifold must be manually reset (see Figure 24).**

21. **CIRCUIT BREAKERS.** The function of the circuit breakers is to protect the various electrical circuits of the machine. The circuit which is protected by each circuit breaker is marked on the decal above the circuit breakers. An electrical overload will cause the circuit breaker button to move outward, indicating that the circuit breaker has tripped. Reset the circuit breaker by depressing the button. If the same circuit breaker should trip shortly after it is reset, check the circuit protected by the circuit breaker for the cause of the overload.

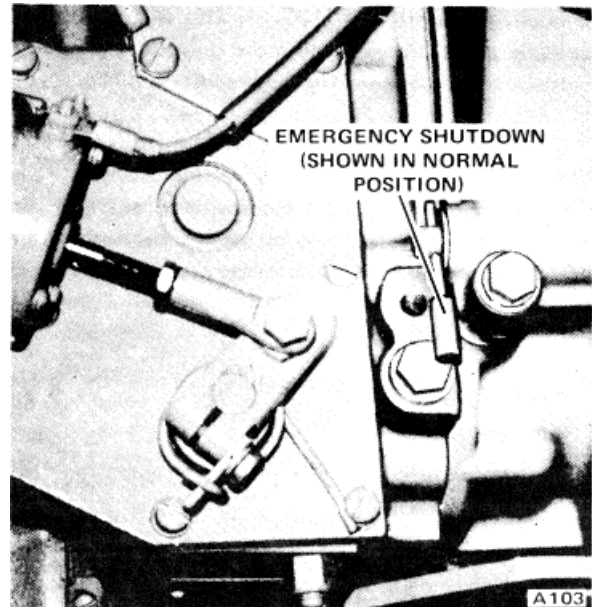

*Figure 2-4. Emergency Engine Shut Off*

### **WARNING**

**Under no circumstances should the circuit breakers be prevented from tripping by any means. Overloaded electrical circuits can cause extensive damage to the machine and/or could cause injury to personnel.**

22. **THROTTLE SELECTOR VALVE.** This valve transfers control of the throttle from the lower to the upper. Place the lever in the LOWER position when driving the carrier. Place the lever in the UPPER position when operating the upper.

23. **MAIN TRANSMISSION SHIFT LEVER.** This lever is used to select the gears in the main transmission.

24. **AUXILIARY TRANSMISSION SHIFT LEVER.** This lever is used to select the gears in the auxiliary transmission. The auxiliary transmission should be kept in the lowest gear range that will allow the machine to reach the desired maximum speed. Maintaining the auxiliary transmission in a higher than required range could cause gear tooth failure, due to excessive torque from the main transmission.

25. **OUTRIGGER/STEERING SELECTOR VALVE.** This valve transfers hydraulic fluid from the engine driven pump to either the power steering system, or the outrigger system. Push the knob in and engage the latch to direct fluid to the power steering system. Pull the knob out to direct fluid to the outrigger system.

**NOTE**

**The outrigger/steering selector valve is not furnished when the machine is equipped with the optional carrier remote control system. The transfer from outrigger to steering is done automatically when the outrigger master switch is in the OFF position.**

26. PUMP DISCONNECT LEVER. Pull this lever toward rear of cab, to engage the pump drive. Push this lever forward toward dash panel, to disengage the pump drive. The engine must be stopped before engaging or disengaging the pumps.
27. SHIFT CHART. This chart shows the shifting pattern of the main and auxiliary transmissions.
28. IGNITION SWITCH. Turn this key switch clockwise to the START position to start the engine. Allow the key to return to the ON position as soon as the engine has started.

**CAUTION**

**If the engine does not start within 30 seconds, release the key and allow the starter motor to come to a stop and rest for two minutes before attempting to start the engine again.**

29. ENGINE WATER TEMPERATURE GAUGE. This gauge shows the temperature of the engine coolant. The gauge should read between 160 and 185 F. (71.85° C.) during normal operation.
30. SPEEDOMETER, ODOMETER. The speedometer shows carrier speed in miles per hour, while the odometer indicates the total numbers of miles the carrier has traveled.
31. ENGINE OIL PRESSURE GAUGE. This gauge should read between 40 and 60 psi (2.754.14 bars) during normal operation.
32. R.H. DIRECTIONAL SIGNAL INDICATOR
33. ENGINE WARNING LIGHT. This light is furnished when the machine is equipped with the optional engine warning system. This light, when illuminated, indicates that the engine is overheated or the engine oil pressure is below normal.
34. FUEL GAUGE. This gauge shows the amount of fuel remaining in the fuel tank.
35. LIGHT SWITCH. Pull this switch out halfway, to the detent, to use the tail lights, clearance lights, and

dash panel' lights. Pull this switch out fully to use the headlights in addition to the other lights. Push this switch in completely to turn off all the lights.

36. CLUTCH PEDAL. Depress this pedal to disengage the engine from the transmission when shifting gears. Do not use this pedal for a foot rest, as this will lead to rapid clutch wear.
37. HEADLIGHT DIMMER SWITCH. The headlight dimmer switch allows the driver to raise or lower the headlight beams. The highbeam indicator (item 2) will be lit when the high beams are on.
38. BRAKE PEDAL. Depress this pedal to apply the carrier service brakes.
39. ACCELERATOR PEDAL. Depress this pedal to feed more fuel to the engine, thereby increasing carrier speed.
40. SEAT CONTROL (NOT SHOWN). A lever on the left side of the seat locks the seat in position. To adjust the seat, push the lever back toward the rear of the cab and then slide the seat forward or back as desired. Be sure the seat is locked in position before driving the carrier.
41. REMOTE CONTROL AIR VALVE. This valve is only furnished when the machine is equipped with the optional carrier remote controls. Place this lever in the ON position to supply air to the carrier remote controls. Place the lever in the OFF position when the carrier remote controls are not being used.

**CARRIER OPERATION**

**GENERAL.** The following paragraphs are not intended to describe the method of operating the carrier, but to describe the sequence for starting the engine, releasing the parking brakes, running the carrier, and shutting down the engine.

**PREOPERATION INSPECTION.** Before actually operating the machine each day, perform the "A" Maintenance Check outlined in Section IV.

**STARTING THE ENGINE.** To start the engine, proceed as follows:

1. Place the main transmission shift lever in the neutral position.
2. Depress the accelerator pedal slightly and turn the ignition key to the START position. As soon as the

**SECTION II**

engine starts, release the key. Do not hold the starting motor on for more than 30 seconds at one time. If the engine does not start in this period of time, release the ignition key and wait for two minutes before trying to start the engine again.

**NOTE**

**The use of a cold weather starting aid, furnished as an option, may be required in extremely cold weather.**

3. Check all gauges, immediately after the engine starts, to be sure they are reading properly. If the readings are improper, stop the engine immediately and determine the cause of the improper gauge reading before continuing operation.

4. Allow the engine to run at 800 to 1000 RPM for 4 to 5 minutes or preferably until the water temperature reaches normal operating temperature before operating the machine.

**RUNNING THE CARRIER.** To run the carrier, proceed as follows:

1. Engage the auxiliary transmission in a range suitable for the road conditions. The gear range selected should be the lowest range that will allow the machine to travel at the desired speed.
2. Depress and hold the clutch pedal. Shift the main transmission into a range suitable for the road conditions.
3. Depress the brake pedal. Then pull the Maxibrake control knob out from the dash panel. The carrier is now ready to be moved.

**STOPPING THE ENGINE.** To stop the engine, proceed as follows:

1. Place the main transmission lever in the neutral position.
2. Push the Maxibrake control knob in to apply the parking brakes.
3. If possible, allow the engine to idle for 3 to 5 minutes before shutting down the engine. This will allow the engine to cool down and will prevent overheating due to localized residual heat.
4. Depress the Engine Stop button on the dash panel to stop the engine.
5. After the engine has stopped, turn the ignition key to the OFF position.

**CONTROLS AND OPERATION****OUTRIGGER OPERATION**

**GENERAL.** The outriggers on this machine are controlled electrically from each side of the carrier and the upper cab. The control panels on each side of the carrier control only the outriggers on that side of the carrier, while the control panel in the upper cab controls all four outriggers.

**NOTE**

**Older machines have control panels on each side of the carrier that allow all four outriggers to be operated from one control panel. Even though all four outriggers can be operated from one side of the carrier, as a safety precaution, it is suggested that only the outriggers in view, while standing by the control panel, be operated.**

**EXTENDING THE OUTRIGGERS.** To extend the outriggers from the carrier control panels, proceed as follows:

1. Pull the Outrigger/Steering Selector Valve knob out to the OUTRIGGER position. This step is not required when the machine is equipped with the optional carrier remote control system. The transfer from steering to outriggers is accomplished automatically when the MASTER switch on the outrigger control panel is placed in the ON position.

**NOTE**

**The power steering system is inoperative when the selector valve is in the OUTRIGGER position.**

2. Remove the retainer pin, and move the lock pin to the unlocked position on each outrigger. Install the retainer pin to keep the lock pin in the unlocked position (see Figure 25).

**CAUTION**

**Make certain that the swing brake is locked in the applied position with the Swing Brake Lock before extending the outriggers.**

3. Place the MASTER switch in the ON position (see Figure 2-6).

SECTION II

CONTROLS AND OPERATION

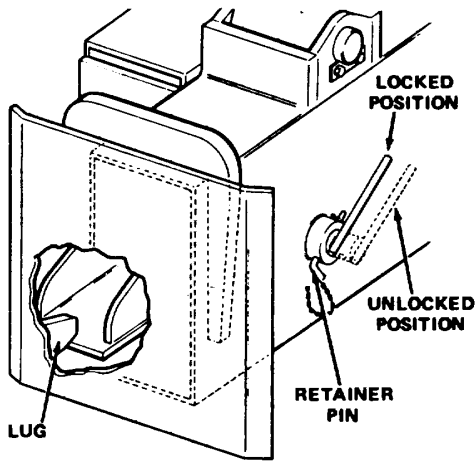

Figure 2-5. Outrigger Locks

4. Extend the outrigger by placing the desired HORIZONTAL switch in the OUT position. Repeat the procedure for the other outrigger.

**WARNING**

Do not set the outriggers near holes, or on rocky, or extremely soft ground. This may cause the machine to tip, resulting in injury to personnel.

5. Lower the outrigger, to raise the machine off the ground, by placing the desired VERTICAL switch in the DOWN position. Repeat the procedure for the other outrigger.

6. Repeat Steps 4 and 5 for the outriggers on the opposite side of the carrier. After all four outriggers have been extended and lowered, make the necessary leveling adjustments by raising or lowering each outrigger as required until the machine is level. Check the level of the machine using the levels on each side of the carrier or in the upper cab.

7. If the machine is equipped with safety locks, engage the safety locks by placing the SAFETY LOCKS switch in the ON position. This step is not required if the machine is not equipped with safety locks.

8. Return the MASTER switch to the OFF position.

**NOTE**

The operation of the outriggers from the upper cab is identical to the procedure described above, except that all four outriggers are controlled from one position in the upper cab.

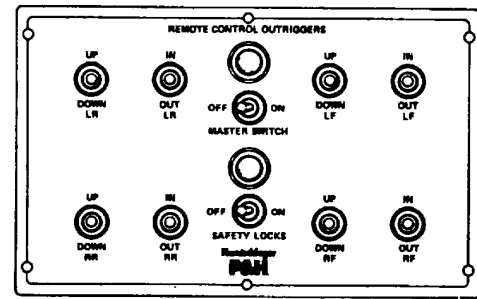

UPPER PANEL

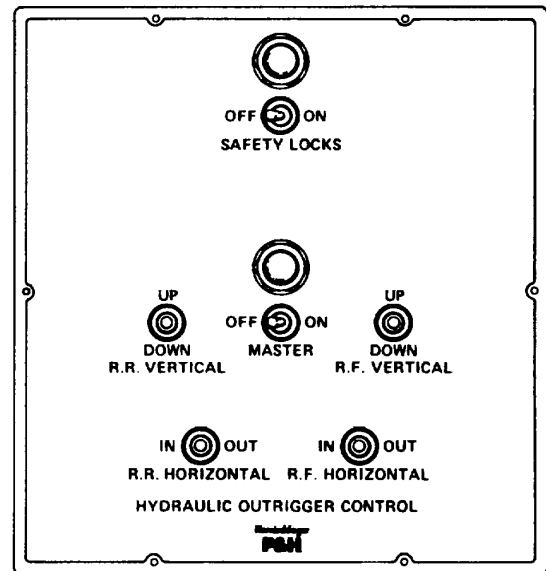

CARRIER PANEL

Figure 2-6. Outrigger Control Panels

RETRACTING THE OUTRIGGERS. To retract the outriggers, proceed as follows:

1. Place the MASTER switch in the ON position.
2. Disengage the safety locks, if the machine is so equipped, by placing the SAFETY LOCKS switch in the OFF position.

**NOTE**

If the weight of the machine is resting on the safety locks it will be necessary to raise the machine slightly, by placing the required VERTICAL switch in the DOWN position, to disengage the safety locks.



## SECTION II

## CONTROLS AND OPERATION

3. Raise the outrigger by placing the desired VERTICAL switch in the UP position. Repeat the procedure for the other three outrigger before they are retracted.
4. Retract each outrigger by placing the appropriate HORIZONTAL switch in the IN position. Be sure the lug on each outrigger float engages the outrigger beam (see Figure 25).
5. Remove the retainer pin, and move the lock pin to the locked position. Install the retainer pin to maintain the lock pin in the locked position.
6. Place the MASTER switch in the OFF position.
7. Push the Outrigger/Steering Selector Valve in and engage the latch to divert hydraulic fluid to the steering system. This step is not required on machines equipped with the optional carrier remote control system. The transfer from outrigger to steering is accomplished automatically when the MASTER switch is placed in the OFF position.

## UPPER CONTROL IDENTIFICATION

The instruments and controls in the upper cab are shown in Figure 27. The numbers on this illustration correspond to the numbers in the following list, which identifies the controls and describes their function.

**CAUTION**

**Holding a control lever in either engaged position after a cylinder has reached its maximum stroke in the corresponding direction will force hydraulic fluid through the relief valve at maximum speed and pressure, and will cause overheating of the hydraulic fluid.**

1. SIGNAL HORN BUTTON. Depress the button on the top of the swing lever to sound the upper signal horn.
2. SWING LEVER. Push this lever forward to swing the upper to the left (toward the boom). Pull this lever back to swing the upper to the right.
3. BOOM TELESCOPE LEVERS. Two levers are used to extend and retract the boom sections. Each lever controls one telescoping section of the boom, and each is identified below:

Lever A controls boom section No. 2.

Lever B controls boom section No. 1.

**CAUTION**

**Be sure to pay out line from the main and/or auxiliary winch, as required, to prevent the hook block(s) from coming in contact with the boom point.**

Push both levers forward to extend all the telescoping sections of the boom. Pull both levers back to retract all the telescoping sections of the boom.

**CAUTION**

**Extend all boom sections equally. If all the sections are not extended equally, operate the control levers individually as required to equalize the boom sections.**

4. AUXILIARY WINCH LEVER. This lever controls the operation of the optional auxiliary winch. When the machine is equipped with a P&H winch, this lever is also used to operate the free-fall feature of the winch. *All P&H winches have free-fall capability. Not all Gearmatic winches have free-fall capability. Gearmatic winches which have the free-fall feature will always be equipped with a separate free-fall lever attached to the winch lever.*

**WARNING**

**Be sure you know whether or not you have a free-fall winch, the make of winch (P&H or Gearmatic), and that you fully understand the operation of the free-fall feature, which is described below, before lifting or lowering a load.**

The auxiliary winch lever will function as follows when the machine is equipped with a P&H winch.

**CAUTION**

**Maintain ample tension on the winch line when lowering light loads to prevent the cable on the winch drum from loosening. If the layers of cable are loose, damage to the cable can occur, resulting in possible damage to the machine or injury to personnel.**

Pull back on the winch lever to lift a load with the auxiliary winch. Push the lever forward, part way, to power down the load (see Figure 28). Push the lever forward, to the extreme forward position, to free-fall the load.

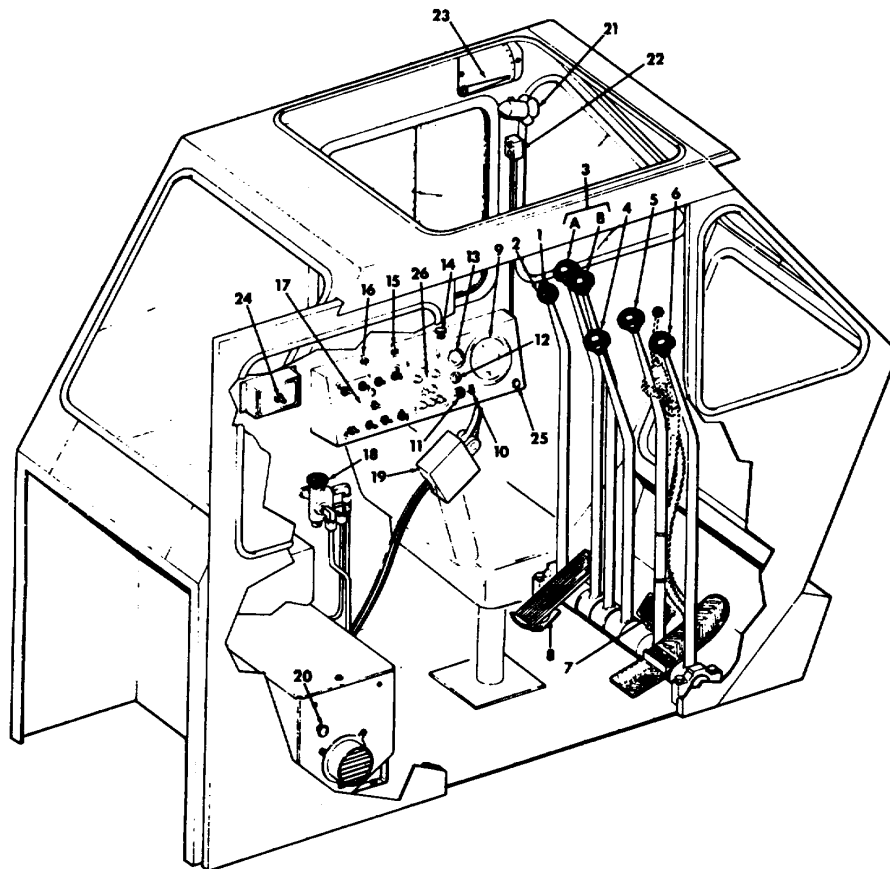

Figure 2-7. Upper Controls

winch. Push the lever forward to power down a load on the auxiliary winch (see Figure 2-8).

### WARNING

Maximum recommended load to be lowered using free-fall must not exceed 50% of the rating plate or hoist reeving chart. Caution must be exercised when using free-fall. Always allow the winch lever to return to the power down position slowly to avoid shock loading of the winch and winch line.

The auxiliary winch lever will function as follows when the machine is equipped with a Gearmatic winch (see Figure 2-8).

Pull the lever back to lift a load with the auxiliary

### WARNING

The Gearmatic winch free-fall feature allows a load to be free-fall lowered whenever the free-fall lever is squeezed, regardless of winch lever position. In other words, it is possible to free-fall a load when the winch lever is in the raise, neutral, or lower positions, just by squeezing the free-fall lever.

Squeeze the free-fall lever toward the winch lever to free-fall lower a load. Release the squeeze lever slowly to return the winch to normal operation. This squeeze lever is only furnished when the Gearmatic winch has a free-fall feature.

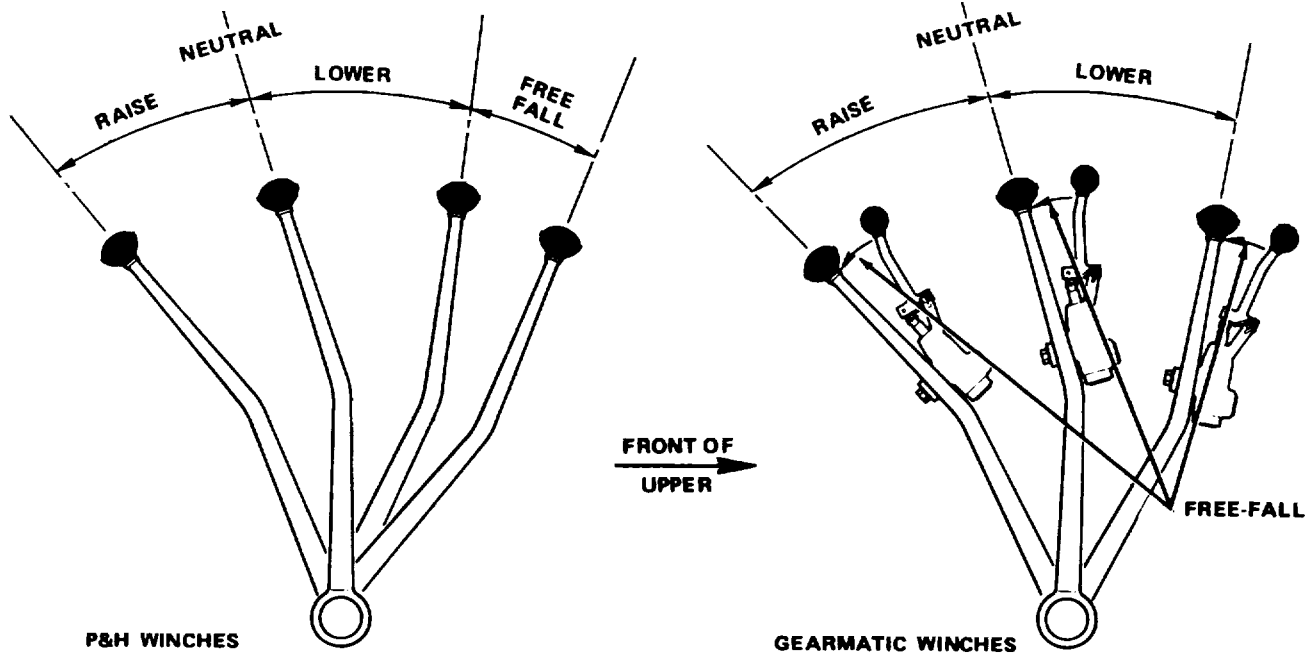

Figure 2-8. Winch Lever Positions

5. MAIN WINCH LEVER. This lever controls the operation of the main winch. The operation of the main winch is identical to that of the auxiliary winch.

6. BOOM HOIST LEVER AND PEDAL. Push this lever (or pedal) forward to lower the boom. Pull this lever (or pedal) to raise the boom.

7. SWING BRAKE PEDAL. Depress this pedal to apply the swing brake. Allow the pedal to return to the free position to release the swing brake.

**NOTE**

This brake is to be used primarily as a holding brake. Movement of the upper should be slowed by plugging the swing lever before the swing brake pedal is depressed.

8. ACCELERATOR. Depress this pedal to increase engine speed. Let up on the pedal to decrease engine speed. Engine speed will return to low idle speed when no pressure is applied to this pedal, unless the engine idle speed has been preset to a higher speed by means of the Hand Throttle.

**NOTE**

The Throttle Selector Valve in the carrier cab must be in the UPPER position to allow the accelerator to control the engine.

9. GAUGE GROUP. The gauge group contains the following: A. Engine Oil Pressure Gauge. This gauge should read between 40 and 60 psi (2.75-4.14 bars) during normal operation.

**CAUTION**

Be sure that engine oil pressure reaches the normal operating range within 15 seconds after starting the engine. If it does not, stop the engine and correct the cause of the pressure failure before restarting the engine.

B. Fuel Gauge. This gauge shows the amount of fuel remaining in the fuel tank.

C. Engine Water Temperature Gauge. This gauge shows the temperature of the engine coolant. The gauge should read between 160 and 185° F. (71-85° C.) during normal operation.

## SECTION II

## CONTROLS AND OPERATIONS

D. Voltmeter. The voltmeter measures the voltage produced by the alternator and indicates the condition of the battery. See Figure 2-2 for an explanation of the voltmeter readings.

10. IGNITION INDICATOR. This lamp is illuminated whenever the ignition switch is in the ON position. If the lamp remains lit after the upper ignition switch is placed in the OFF position, the carrier ignition switch is still in the ON position, and must be placed in the OFF position to shut down the ignition system.

11. ENGINE STOP BUTTON. Depress this button to shut down the engine. After the engine has stopped, place the ignition switch in the OFF position.

12. IGNITION KEY. The ignition key has three positions. Starting from the vertical position they are, OFF ON, and START.

13. TEMPERATURE GAUGE. This gauge measures hydraulic oil temperature. The oil should be warmed to 70° F. (210 C.) before operating the machine, and should not be allowed to exceed 2000 F. (930 C.) during operation.

14. WINDSHIELD WIPER SWITCH. Turn this switch clockwise, to the detent, to operate the upper windshield wiper at slow speed. Turn the switch past the detent to operate the wiper at high speed.

15. MAIN WINCH SPEED SELECTOR SWITCH. Place this switch in the HI position to operate the main winch at high speed. Place the switch in the LO position to operate the winch at low speed.

### CAUTION

**The winch is only capable of producing approximately 50% of the maximum line pull when the speed selector switch is in the HI position. Be sure the switch is in the appropriate position for the load being lifted.**

16. AUXILIARY WINCH SPEED SELECTOR SWITCH. This switch controls the speed of the auxiliary winch. Its operation is identical to that of the main winch speed selector switch.

17. OUTRIGGER CONTROL SWITCHES. These switches control the operation of the outriggers. The operation of the outriggers, from the upper cab, is identical to the operation from the carrier, except that all outriggers can be controlled from the upper cab. Refer to the topic Outrigger Operation for instructions on extending or retracting the outriggers.

18. SWING BRAKE LOCK. Depress this button to lock the swing brake in the applied position. Lift this button to unlock the swing brake.

### NOTE

**This control operates independently of the swing brake pedal, and will override the swing brake pedal.**

19. HAND THROTTLE. Use this lever to set the engine high idle speed, as required for the machine application. For maximum efficiency and safety of operation, the high idle speed must be set high enough, by means of this control, to handle the typical load. The Accelerator should be used for momentary increases in engine speed.

20. HEATER CONTROL. This control regulates the heater temperature and heater fan speed. Turn the knob clockwise to start the heater fan. Fan speed is controlled by turning the knob clockwise or counterclockwise until the desired fan speed is obtained. Heater temperature is increased by pulling the knob outward and is decreased by pushing the knob inward.

21. DEFOGGER FAN. The defogger fan is controlled by the switch on the fan housing. Place the switch in the center position to operate the fan at low speed. Place the switch in the extreme right position to operate the fan at high speed.

22. WINCH TURN INDICATORS. These lights indicate the rate at which the winch drums are turning. The upper light indicates main winch rotation, while the lower light indicates auxiliary winch rotation. The lights will flicker whenever the winch drums are turning. The light will flicker at different rates depending upon how fast the winch drum is turning.

### NOTE

**The lights will have a slight glow when the winches are not turning, and will increase in intensity when the winches are turning. This slight glow provides a means of checking the lamps in the turn indicators. The lamp should be replaced if it does not glow, as it is burned out.**

23. BOOM ANGLE INDICATOR. This gauge indicates the number of degrees the boom is raised above the horizontal.

24. FLOODLIGHT SWITCH. This switch, or switches, turn the optional floodlights on and off.

25. ENGINE WARNING LIGHT. This light, when illuminated, indicates that the engine is overheated or the engine oil pressure is below normal.

## SECTION II

## CONTROLS AND OPERATION

26. CARRIER REMOTE CONTROLS. These switches are used to operate the carrier from the upper cab. Refer to the topic Remote Control Carrier Operation.

### CRANE OPERATION

GENERAL. The following operating suggestions are offered as a reminder rather than as an attempt to instruct, since the Harnischfeger Corporation is well aware of the fact that a machine of this size is not entrusted to anyone except a fully qualified operator.

1. Always consult the rating plate in the upper cab for the maximum load which may be lifted with the various combinations of boom length, boom angle, and other variable factors which may be involved with lifting the load.
2. Always perform all machine operations with the engine running at governed speed. Machine performance and safety of machine operations require that the engine be run at governed speed.
3. When the load is being swung, it should be kept as near the machine and as close to the ground as possible.
4. Always pay out cable from the main and/or auxiliary winch when the boom is being extended or when the boom is being lowered to prevent "two blocking" the hook block.
5. Always set the outriggers before operating the machine.

PREOPERATION INSPECTION. Before actually operating the machine each day, perform the "A" Maintenance Check outlined in Section IV.

STARTING THE ENGINE. To start the engine from the upper cab, proceed as follows:

1. Perform the following functions before leaving the carrier cab:
  - A. Shift the main transmission to neutral.
  - B. Place the Throttle Selector Valve in the UPPER position.
  - C. Engage the pump drive.
  - D. Apply the Maxibrakes by pushing the Maxibrake button in.
2. Turn the upper ignition key clockwise, past the detent, to start the engine. Do not hold the starter on

for more than 30 seconds at one time. If the engine does not start in this period of time, release the ignition key, and wait two minutes before attempting to start the engine again.

3. Check all gauges, *immediately after the engine starts*, to be sure they are reading properly. If the readings are improper, stop the engine immediately and determine the cause of the improper gauge reading before continuing operation.

4. Allow the engine to run at 800 to 1000 rpm for 4 to 5 minutes or preferably until the water temperature reaches normal operating temperature before working the machine.

CRANE OPERATING CYCLE. The crane operating cycle consists of six steps: setting the boom angle (boom hoist operation), setting the boom length (boom telescope operation) lifting the load (hoisting operation), swinging the load, spotting the load, and lowering the load (see Figures 2-9 and 2-10).

#### CAUTION

**Figure 2-9 illustrates the operation of the machine when it is equipped with P&H winches, while Figure 2-10 illustrates the operation of machines equipped with Gearmatic winches. The operation of these machines is different. Therefore, be sure you understand the operation of your machine before you begin to operate it. The operation of both types of winches is described in the topic Upper Control Identification.**

STOPPING THE ENGINE. To stop the engine, proceed as follows:

1. Make certain that all controls are in the neutral position, and the swing brake is locked in the applied position. Lower the boom onto the boom rest or to a horizontal position.

2. If possible, allow the engine to run at half speed or less for several minutes before stopping the engine. This will allow the engine to cool down.

3. Depress the Engine Stop Button to stop the engine. *After the engine has stopped*, place the ignition key in the OFF position.

## CARRIER REMOTE CONTROLS

## GENERAL

The purpose of the carrier remote controls is to provide a means of moving the carrier, without having to leave the upper cab.

## CONTROL IDENTIFICATION

The controls provided on the carrier remote control panel are shown in Figure 2-11. The function of the controls are as follows:

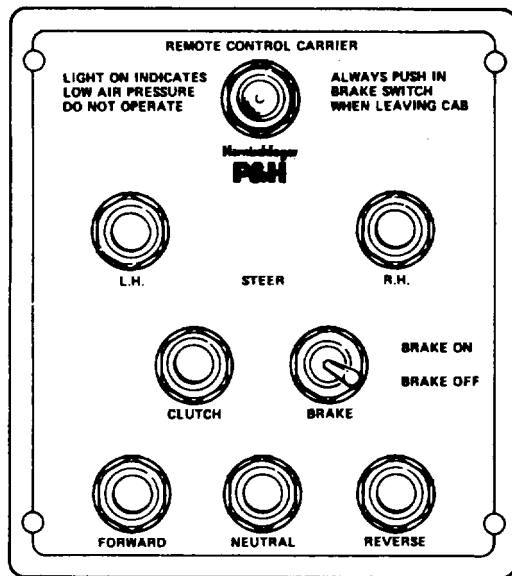

Figure 2-11. Carrier Remote Control Panel

1. **LOW AIR PRESSURE LIGHT.** This lamp, when illuminated, indicates that the air pressure is below the pressure required to operate the carrier by remote control. *Do not operate the carrier by remote control when this lamp is illuminated.*

2. **L.H. STEER.** Depress and hold this button to turn the front wheels to the left. The number of degrees that the wheels are turned vary with the length of time the button is held depressed. Release the button to stop turning the wheels.

3. **R.H. STEER.** This button operates in the same manner as the L.H. Steer button, except that this button causes the wheels to turn to the right.

4. **CLUTCH.** This button controls the operation of the clutch. Depress and hold this button to disengage the clutch. Release the button to engage the clutch.

5. **BRAKE.** This toggle switch controls the operation of the carrier *service* brakes. Place the switch handle in the up position to apply the brakes. Place the switch handle in the down position to release the brakes.

6. **FORWARD.** This button, when used in conjunction with the Clutch button, shifts the main transmission into first gear.

7. **NEUTRAL.** This button, when used in conjunction with the Clutch button, shifts the main transmission into neutral.

8. **REVERSE.** This button, when used in conjunction with the Clutch button, shifts the main transmission into reverse.

## OPERATION

To operate the carrier by remote control, proceed as follows:

**CAUTION**

The following instructions describe the steps necessary to transfer control of the carrier from the carrier cab to the upper cab. These instructions must be followed carefully to ensure safe, proper transfer of carrier control.

1. Perform the following function before leaving the carrier cab:

- A. Shift the main transmission to neutral.
  - B. Shift the auxiliary transmission to low gear.
  - C. Place the Remote Control Air Valve in the ON position.
  - D. Place the Throttle Selector Valve in the UPPER position.
2. Go to the upper cab and place the Ignition switch in the ON position. Then place the Brake switch in the BRAKE ON position.

**WARNING**

Be sure the Low Air Pressure Light, on the carrier dash panel, is not lit before releasing the Maxibrakes. If the light is lit, it is possible that the carrier could move because the air pressure is not sufficient to apply the service brakes via the remote control system.

## SECTION II

## CONTROLS AND OPERATION

3. Return to the carrier cab and release the Maxibrakes by pulling out the Maxibrake button.

4. The carrier can now be operated from the upper by remote control as follows:

A. Start the engine by turning the Ignition key to the START position.

B. Raise the outriggers to the stored position, if they are extended, as described in the topic Outrigger Operation. Be sure the MASTER switch on the outrigger control panel is returned to the OFF position.

C. Depress the Clutch and either the Forward or Reverse buttons on the carrier remote control panel to engage either the first or reverse gear of the main transmission.

D. Release the Forward or Reverse button, while maintaining the Clutch button in the depressed position.

E. Place the Brake switch in the BRAKE OFF position.

F. Release the Clutch button to engage the clutch.

G. Control the speed of the carrier with the Accelerator, and steer the machine in the desired direction by depressing the Steer Left or Steer Right buttons as required.

H. Stop the carrier by first depressing the Clutch button, and then place the Brake switch in the BRAKE ON position. Maintain the Clutch button in the depressed position while the carrier is stopped, or shift the transmission to neutral by depressing the Neutral button. The Clutch button can be released when the transmission is in the neutral.

5. To transfer control of the carrier back to the carrier cab, perform the following steps:

A. Shift the main transmission to neutral by depressing the Clutch and Neutral buttons.

B. Place the Brake switch in the BRAKE ON position.

C. Go to the carrier cab and apply the Maxibrakes by pushing the Maxibrake button in.

D. Return to the upper cab and place the Brake switch in the BRAKE OFF position. Place the Ignition key in the OFF position if the machine is to be completely shut down.

E. Place the Remote Control Air Valve in the carrier cab in the OFF position. Place the Throttle Selector

Valve in the LOWER position. The operation of the carrier is now controlled from the carrier cab.

### HAND SIGNALS

It is frequently necessary during crane operation for the operator to depend on a signalman for instructions. When moving the machine into a position where there is very limited clearance, or when handling loads that are out of sight of the operator, the use of a signalman is essential. The hand signals illustrated in Figure 2-12 are those generally accepted throughout the industry. Both the operator and the signalman should be thoroughly familiar with the standard hand signals illustrated to ensure cooperation and teamwork.

### OPERATION UNDER UNUSUAL CONDITIONS

**GENERAL.** Unusual conditions refer to environment; specifically, extreme cold, extreme heat, dusty or sandy conditions, areas with high humidity or salt air, and high altitudes. Separate paragraphs are devoted to each of these conditions.

**OPERATION IN EXTREME COLD.** Operation in extreme cold presents special problems due to the increased brittleness of metallic and rubber parts, the danger of freezing and the increased difficulty of keeping parts lubricated adequately.

#### **WARNING**

**Personnel should use care to keep from spilling fuel, coolant, or other liquids upon themselves. Exposed parts of the body should not come into contact with metal during cold weather, as serious and painful injury may result.**

1. Refer to Section III, Lubrication for lubricant recommendations for cold weather operation. Change the lubricant if necessary.

2. Drain and flush the cooling system, to insure proper circulation of coolant throughout the radiator core. Clean the radiator cooling fins, particularly the air passages through the core.

Check the condition of the radiator hoses, clamps, thermostat and radiator core.

ALWAYS STAND IN CLEAR VIEW OF CRANE OPERATOR. BE SURE TO STAY A SAFE DISTANCE FROM HOOK BLOCK OR BOOM.





 <p><b>EMERGENCY STOP.</b> Arm extended, palm down, move hand rapidly right and left.</p>	 <p><b>STOP.</b> Arm extended, palm down, hold position rigidly.</p>	 <p><b>DOG EVERYTHING.</b> Clasp hands in front of body.</p>	 <p><b>MOVE SLOWLY.</b> Use one hand to give any motion signal and place other hand motionless in front of hand giving the motion signal. (Hoist Slowly shown as example)</p>
 <p><b>RAISE BOOM.</b> Arm extended, fingers closed, thumb pointing upward.</p>	 <p><b>LOWER BOOM.</b> Arm extended, fingers closed, thumb pointing downward.</p>	 <p><b>USE MAIN HOIST.</b> Tap fist on head; then use regular signals.</p>	 <p><b>USE WHIP LINE. (Auxiliary Hoist)</b> Tap elbow with one hand; then use regular signals.</p>
 <p><b>SWING.</b> Arm extended point with finger in direction of swing of boom.</p>	 <p><b>TRAVEL.</b> Arm extended forward, hand open and slightly raised, make pushing motion in direction of travel.</p>	 <p><b>TRAVEL. (One Track)</b> Lock the track on side indicated by raised fist. Travel opposite track in direction indicated by circular motion of other fist, rotated vertically in front of body. (For crawler cranes only)</p>	 <p><b>TRAVEL. (Both Tracks)</b> Use both fists, in front of body, making a circular motion, about each other, indication direction of travel; forward or backward. (For crawler cranes only)</p>
 <p><b>HOIST.</b> With forearm vertical, forefinger pointing up, move hand in small horizontal circle.</p>	 <p><b>LOWER.</b> With arm extended downward, forefinger pointing down, move hand in small horizontal circles.</p>	 <p><b>RAISE THE BOOM AND LOWER THE LOAD.</b> With arm extended, thumb pointing up, flex fingers in and out as long as load movement is desired.</p>	 <p><b>LOWER THE BOOM AND RAISE THE LOAD.</b> With arm extended, thumb pointing down, flex fingers in and out as long as load movement is desired.</p>
 <p><b>RETRACT BOOM. (Telescoping Boom)</b> One Hand Signal. One fist in front of chest, thumb pointing outward and heel of fist tapping chest.</p>	<p style="text-align: center;"><b>FOR HYDRAULIC MACHINES ONLY</b></p>  <p><b>EXTEND BOOM. (Telescoping Boom)</b> One Hand Signal. One fist in front of chest with thumb tapping chest.</p>		 <p><b>EXTEND BOOM. (Telescoping Booms)</b> Both fists in front of body with thumbs pointing outward.</p>
			 <p><b>RETRACT BOOM. (Telescoping Booms)</b> Both fists in front of body with thumbs pointing toward each other.</p>

Figure 2-12. Hand Signals for Crane Operation

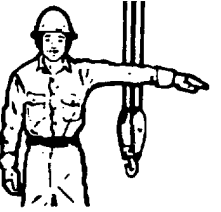
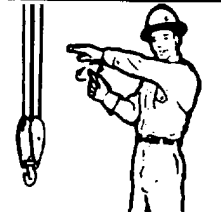
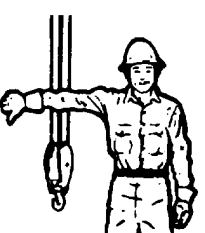

## SECTION II

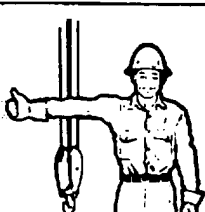
## CONTROLS AND OPERATION

When assured that the cooling system is clean, and in good condition, refill the system with an ethylene/glycol and water solution of the proper strength for the anticipated low temperatures.

### NOTE

**A high quality corrosion inhibitor can be added to the cooling system, if desired. Do not, however, use a Chromate base inhibitor with an ethylene/ glycol anti-freeze. That combination can produce Chromium Hydroxide, commonly known as "green slime".**

3. Keep the battery fully charged at all times. The electrolyte in a discharged battery will freeze at a higher temperature than that in a fully charged battery.

### NOTE

**If it is necessary to add water to the battery, do so only immediately before or during operation, or with an external charger connected to the battery. Charging the battery, by any means, mixes the water and electrolyte, and thereby prevents the water from freezing.**

Keep the battery terminal connections clean and free from snow or ice which could short circuit the terminals. Clean the cable connectors and battery posts thoroughly, using a soda and water solution to remove corrosion.

In extremely cold weather, it is advisable to remove the battery and store it in a heated area if the machine is to be idle overnight or for any extended period.

4. Keep the fuel tank as full as possible at all times to minimize condensation. If water is detected in the fuel supply, drain the tank and refill it with clean fuel.

5. Engage the pump drive and jog the starter for about one minute to move hydraulic oil through the pumps, thereby insuring proper lubrication of pump components. Then start the engine in accordance with the engine manufacturers recommendations for cold weather starting, and run it at approximately 1200 RPM until the engine has warmed up.

### NOTE

**Cover part of the radiator, to aid warmup and to maintain engine running temperature. During warmup only, the entire radiator may be covered.**

6. After the hydraulic oil has warmed to a minimum of 70° F. (21° C.), slowly and gradually actuate each cylinder a number of times, in turn, without allowing the cylinders to travel to the end of their stroke. Then slowly swing the upper and operate the winches in both directions. The oil in the lines and other components of these systems will thus be warmed.

### CAUTION

**Cold fluid makes relief valves sluggish in operation. It can add 500 to 1000 psi (34.5-68.9 bars) to the maximum pressure setting of the relief valves. Therefore, extreme care must be used when actuating a cold system to prevent a hose or tube from rupturing, or causing other damage.**

7. Before shutting down the machine, raise the outriggers to the stored position, and drive the machine onto wooden planks or mats to prevent the machine from being frozen to the ground.

**OPERATION IN EXTREME HEAT.** Operation in extreme heat presents special problems due to the difficulty in keeping the engine and hydraulic oil from overheating.

1. Refer to Section III, Lubrication for lubricant recommendations for hot weather operation. Change the lubricant if necessary.

2. Make certain that the engine crankcase oil is at the proper level. An inadequate supply of crankcase oil will prevent proper dissipation of heat from the engine.

3. Drain and flush the cooling system, to insure proper circulation of coolant throughout the radiator core. Clean the radiator cooling fins, particularly the air passages through the core, of insects, leaves, dirt, and other foreign material that will restrict air flow.

4. Inspect the cooling system for leaks. Replace worn or damaged hoses. Tighten the hose clamps.

5. Keep the water pump fan belt adjusted properly.

6. If the engine becomes overheated from lack of coolant, let the engine run at a fast idle and add coolant slowly.

7. If the engine overheats after refilling the cooling system, shut down the engine and allow it to cool. Drain the cooling system by opening the drain cocks on the radiator and the engine block, and flush out the system. Refill the cooling system with clean water; *do not use salt or mineral water solutions in the cooling system.*

## SECTION II

## CONTROLS AND OPERATION

8. Keep as much air as possible circulating around the battery. Check the electrolyte level frequently; add distilled water as necessary to keep the electrolyte level 3/8 inch (9.2 mm) above the plates.

9. Keep the air intake and exhaust openings clear. Keep the engine clean, and allow air to circulate freely around the engine.

10. Avoid racing the engine; and avoid operation at full throttle when part throttle will handle the load.

11. Avoid lugging the engine; keep the engine speed high enough to maintain fan speed.

12. Avoid idling the engine unnecessarily; shut the engine down during a lull in the operation.

**OPERATION IN DUSTY AND SANDY AREAS.** Operation in dusty or sandy areas present special problems due to the abrasive action of dust which shortens the life of parts. Make every effort to keep dust and sand out of the moving parts of the crane machinery and engine.

1. All lubricants and lubricating equipment must be kept clean. Service breathers and air cleaner frequently to remove accumulated sand and dust. Lubricate more frequently to keep a supply of clean lubricant in the moving parts. Clean all lubrication fittings thoroughly before attaching the grease gun.

2. Keep the fuel tank filler cap tight to prevent sand or dust from entering the fuel tank. Service fuel filters frequently to keep them free from sand and dust.

3. Keep the hydraulic oil reservoir filler cap tight to prevent sand and dust from entering the hydraulic system. Service the hydraulic oil filter frequently to keep the system free from sand and dust.

4. Use wood blocking or mats under the outrigger jack-stands when operating in sand. See that the carrier does not shift during operation.

**OPERATION IN HUMIDITY OR SALT WATER AREAS.** Moisture and salt will cause deterioration of paint, cables, wiring, and all exposed metallic parts. Keep parts dry and well lubricated in high humidity or salt water conditions.

1. Completely remove rust and corrosion at the first appearance on any part of the truck crane. Wash off salt water and dry all parts thoroughly; paint the exposed surfaces immediately. Place a film of lubricant or grease on all polished or machined metal surfaces and other surfaces which cannot be painted.

2. Keep parts lubricated thoroughly to repel water from polished metal surfaces and to prevent the entry of water into bearings. Keep lifting cables lubricated.

### OPERATION AT HIGH ALTITUDES.

Operation at high altitudes present special problems due to lower atmospheric pressure and wide temperature ranges. At altitudes above 5000 feet (1524 m) it may be necessary to change the engine fuel injectors. Make certain that the air cleaner is clean and free from obstructions. Check the engine frequently for overheating.

### INSTALLING ROPE ON DRUMS

The manner in which a new or replacement wire rope is installed on the winch drum will, to a large measure, determine the service life of that rope. Improperly wound ropes will cause undue crushing of the rope, doglegs, kinks, excessive abrasion and cutting of the individual wires. Bad spooling also causes uneven application of force and motion. This results in fast fatiguing of the rope from the hook block to the drum. The following five precautionary steps should be taken, particularly with a replacement wire rope, before starting the actual installation of the rope.

1. A check should be made of the drum to determine the condition, size and shape of the drum grooves.

2. Drum flanges should be checked to determine the extent, if any, of undercutting at the base of the flange,

3. Dirt, grit, or any other type of debris should be cleaned off the drum.

4. Bearings should be checked.

5. Cracks or breaks in the drum should be reported. Whenever any of these conditions are observed, the winch should be removed from service and properly cleaned, repaired or replaced. This recommendation is made not only to improve or maintain good rope life, but to eliminate a potential hazard.

After establishing the satisfactory condition of the winch drum, mount the reel of wire rope on suitable jacks at the front of the boom. Pass the end of the rope over the idler sheave at the boom point and attach the rope to the winch drum as shown in Figure 2-13.

#### NOTE

**A tension should be induced into the rope by providing some means of braking the shipping reel while installing the rope on the winch drum. A tight winding is imperative.**

REEVING

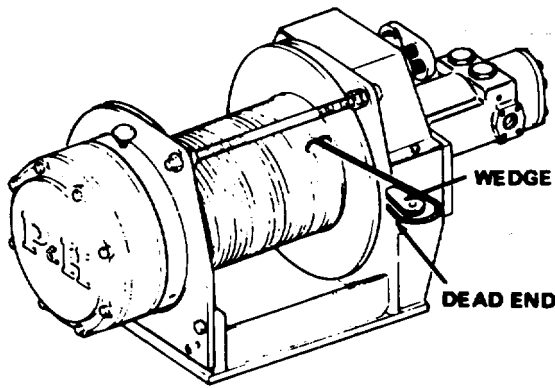

Figure 2-13. Securing Rope to Drum

Slowly wind the rope onto the winch drum by moving the winch lever to the raise position. A lead or brass hammer may be useful in tapping the rope over as it is being wound on the drum. Do not use a steel hammer or pinch bar. These can readily cause damage to the rope

Reeving diagrams for the main hoist line are shown in Figure 2-14. The number of parts of line (from one to seven) used in reeving the main hoist line will depend on the load to be lifted. Refer to the rating chart in the upper cab to determine reeving requirements for various loads. Hoisting and lowering speeds decrease as the number of parts of line increases. When practical, use the minimum number of parts required for the loads to be lifted.

Boom reeving diagram for clamshell operation is shown in Figure 2-14.1.

NOTE

Jib reeving is limited to a single part of line. The main or auxiliary winch line can be used to reeve the jib. The auxiliary winch line cannot, however, be used for reeving the main hoist line.

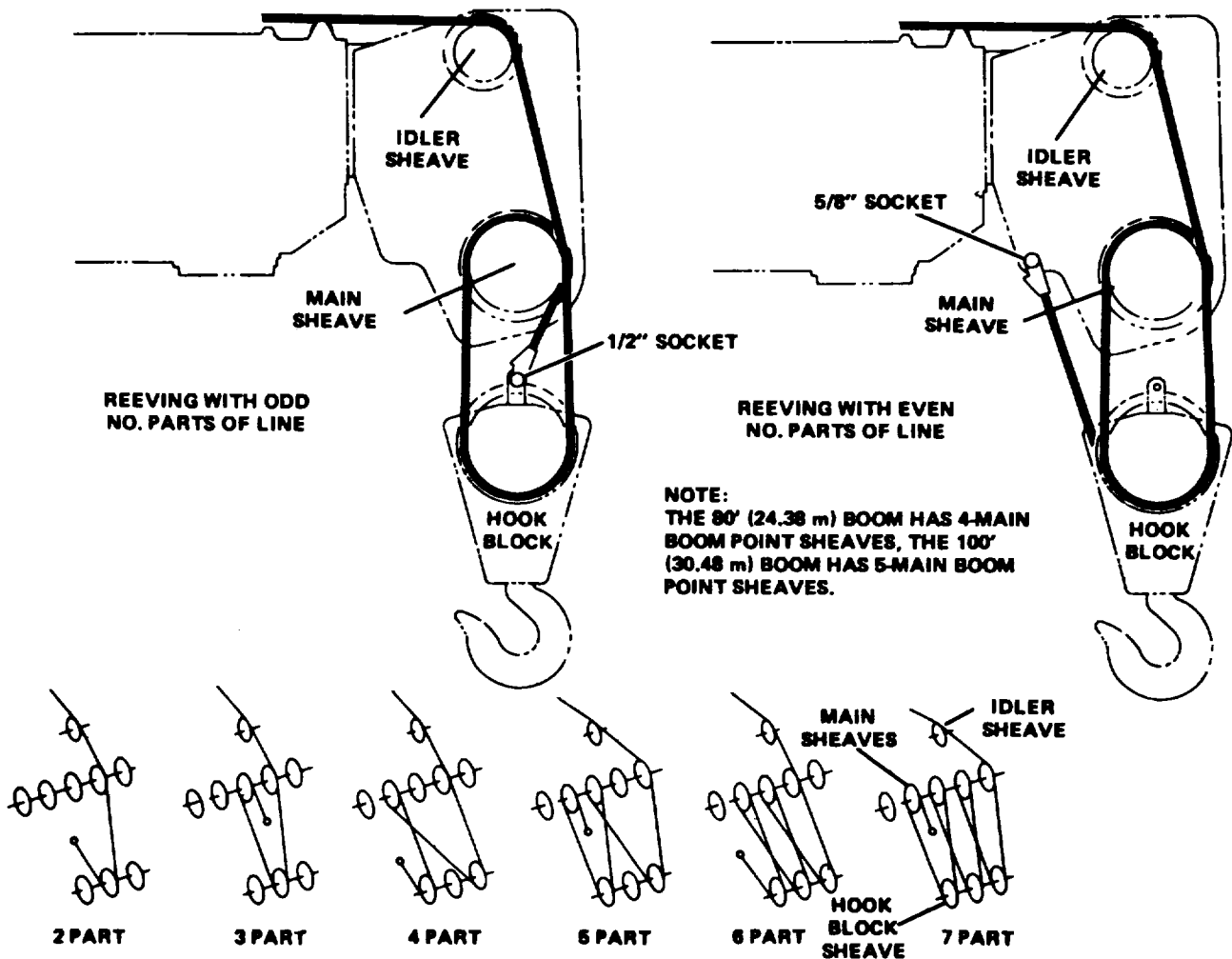
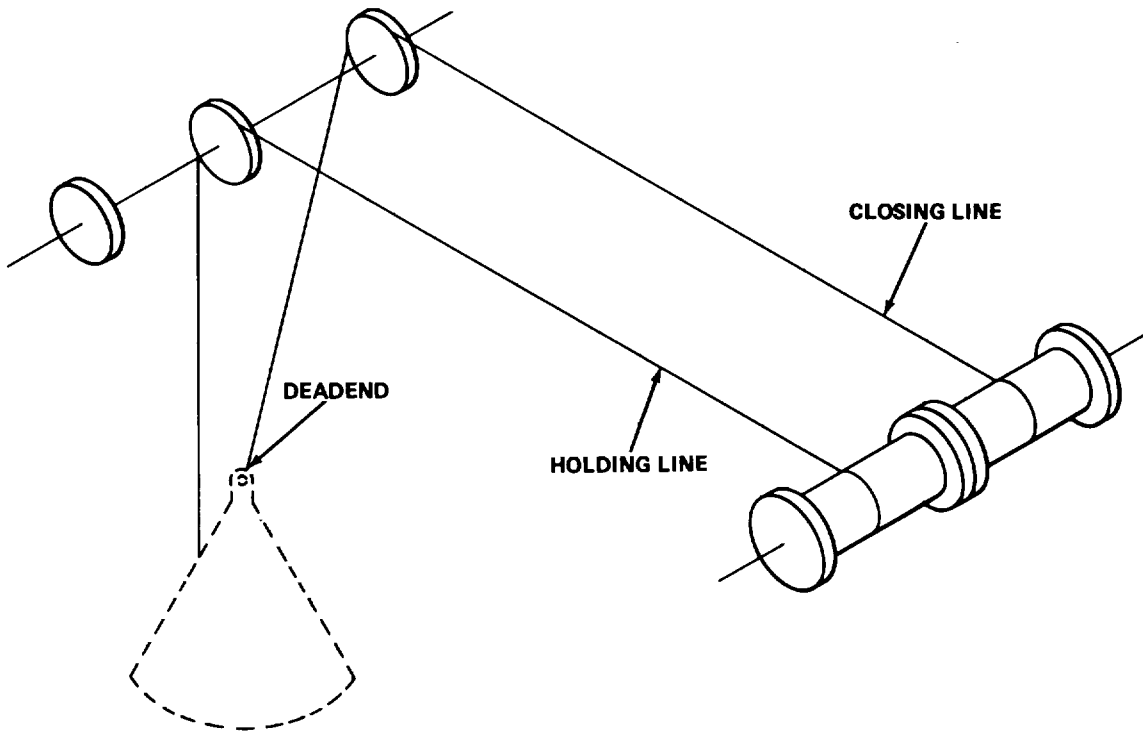

Figure 2-14. Reeving Diagram (105N416)



TA217513 ■

Figure 2-14.1 Boom Reeving For Clamshell Operation

Change 1 1-2-22.1/(1-2-22.2 blank)

## SECTION II

## CONTROLS AND OPERATION

The dead end of the rope is attached to the hook block (or boom point) with a wedge type rope socket. The rope socket should be installed on the rope as follows (see Figure 2-15):

1. Place the socket in an upright position as shown in View A, and bring the rope around in a large, easy to handle loop.
2. The dead end of the rope should extend from the socket for a distance of at least one rope lay, permitting the strands to adjust around the wedge and to keep the rope in balance. Insert the wedge as shown in View B.
3. Secure the ears of the socket to a sturdy support and carefully take a strain on the live side of the rope. Pull the wedge and rope loop into position tight enough to hold the wedge in place during handling. Final wedge positioning takes place under full operating loads.
4. After the socket is pinned to the hook block (or boom point), apply gradually increasing loads until the wedge is seated. Avoid applying any sudden shock loads before the wedge is in its final position. View C shows the general operating appearance of the rope socket with the wedge pulled into the socket and the end of the wedge showing.

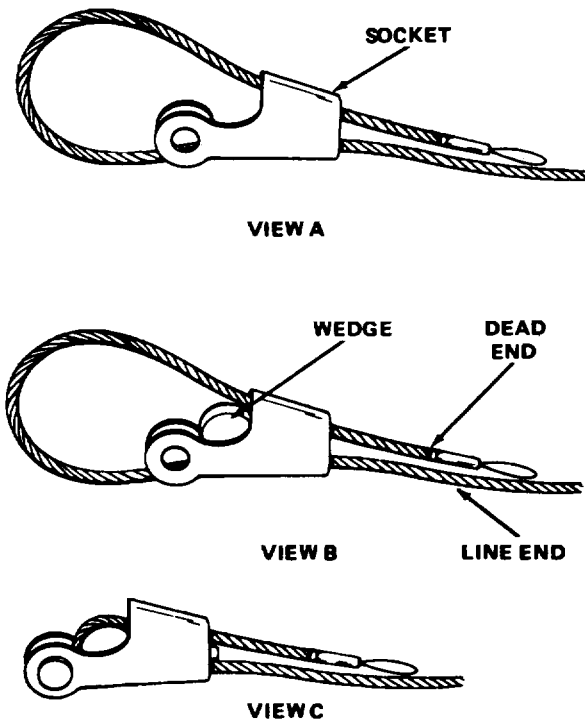

Figure 2-15. Installing a Rope Socket

## JIB ATTACHMENT

The optional jib attachment is mounted on the boom point when it is in the operating position, and is stored under the boom when not used.

### NOTE

**Consult the rating plate in the operator's cab for lifting capacities when operating with the jib attachment.**

To place the jib into the operating position from the storage position, proceed as follows (see Figure 2-16):

1. Rotate the upper so that the boom is over either side or the rear of the carrier. *Do not attempt to unfold the jib with the boom over the front of the carrier.*
2. Install T-pins (1), spacers (2), and cotter pins (3) to attach the jib to the boom point. Install the T-pin upward from the bottom so that the cotter pin will be on the bottom side of the jib when it is erected.
3. Remove the hook block from the main or auxiliary winch line, and attach the line to becket (4) with a rope socket. Take up the slack in the line with the winch, so that the jib point is supported by the line.
4. Remove capscrews (5), lockwashers (6), retainers (7) and spacers (8). Remove cotter pin (9) and pin (10).
5. Elevate the boom to an angle of approximately 45 degrees, and extend the boom while paying out on the winch line until the jib is suspended vertically from the boom point.
6. Disconnect the winch line from becket (4) and attach it to becket (11). Take up slack in the winch line to raise the jib to the operating position.
7. Attach the jib suspension cable as shown in Figure 2-17 to fix the jib at the required operating angle. The angle at which the jib operates can be varied by increasing or decreasing the length of the suspension cable by means of cable links. The cable links are installed between the main suspension cable and the boom point. Figure 2-17 illustrates the positions at which the jib can operate, and the number of cable links required to obtain the operating angles shown.
8. Remove the winch line from becket (11) and attach the hook block to the line.

To place the jib into the storage position from the operating position, proceed as follows (see Figure 2-16):

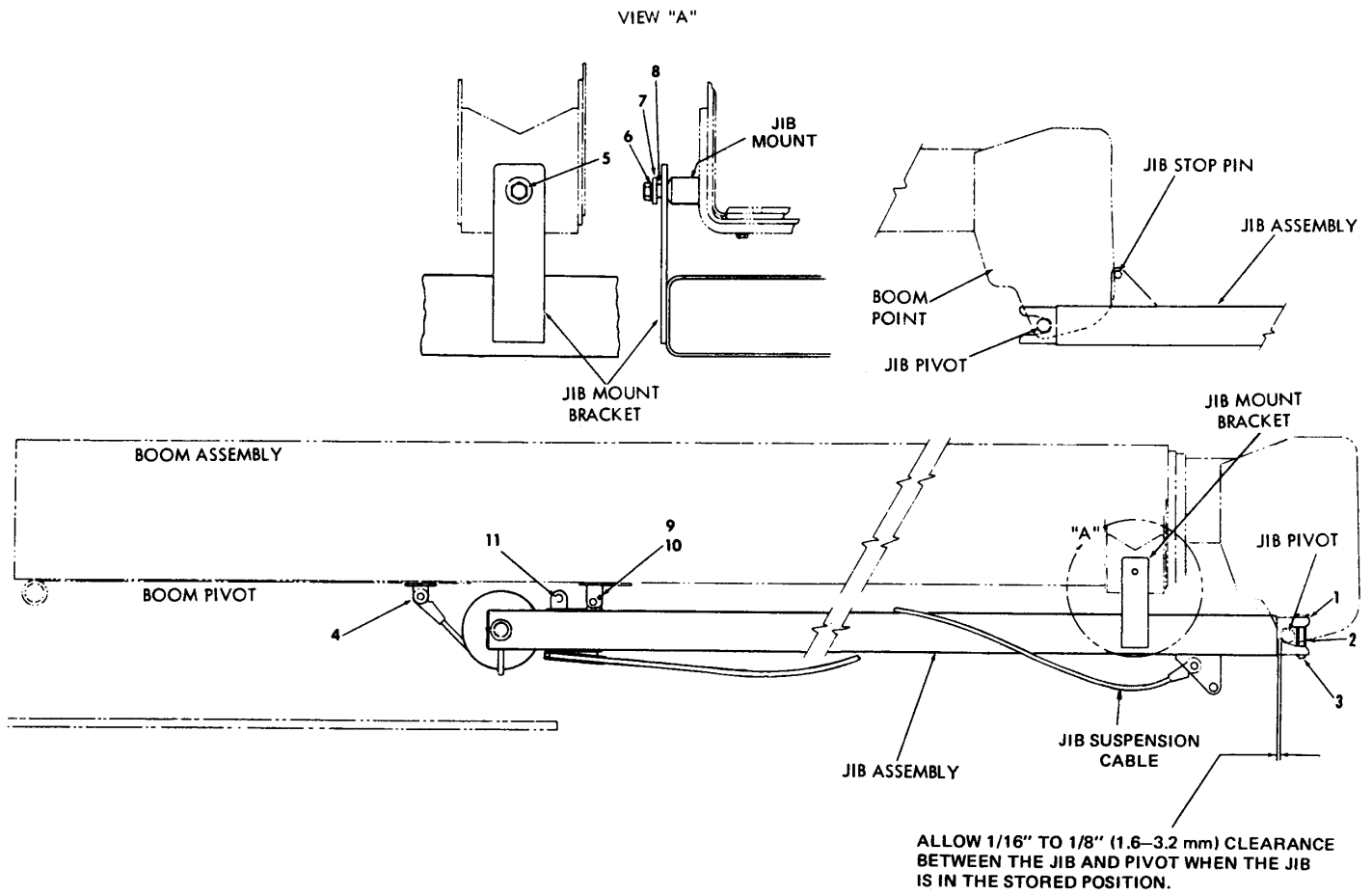

Figure 2-16. Jib Storage (911J90-E)

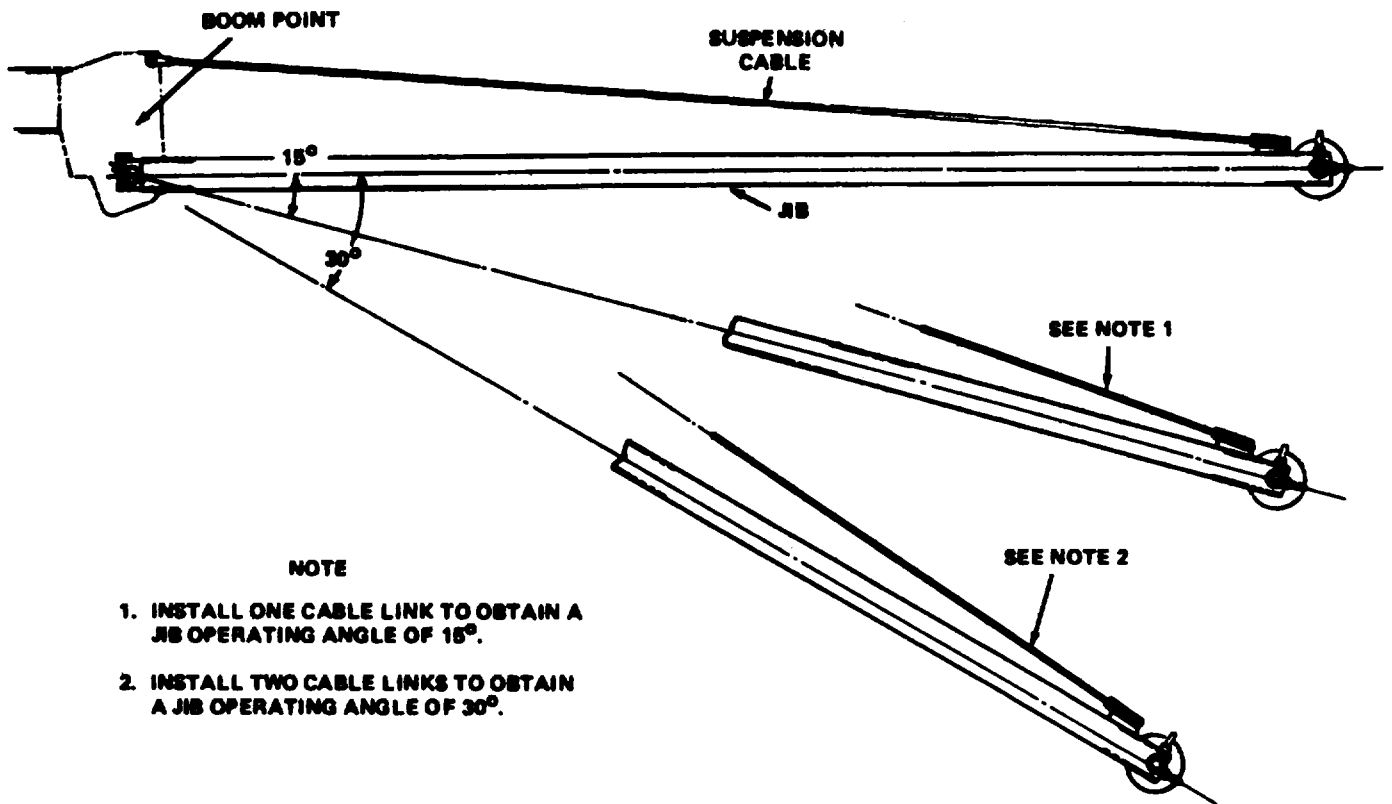

Figure 2-17. Jib Suspension (911J91)

1. Rotate the upper so that the boom is over either side of the rear of the carrier. *Do not attempt to fold the jib with the boom over the front of the carrier.*

2. Remove the hook block from the main or auxiliary winch line, and attach the line to becket (11). Take up on the winch line to relieve the tension on the jib suspension cable.

3. Remove the suspension cable from the boom point and attach it to the bracket at the base of the jib as shown in Figure 2-16. Elevate the boom to an angle of approximately 45 degrees, and pay out line from the winch slowly, until the jib is suspended vertically from the boom point.

4. Telescope the boom back, leaving approximately one foot of boom extended.

5. Remove the winch line from becket (11) and attach it to becket (4). Slowly lower the boom and take up slack in the line with the winch to fold the jib under the boom.

6. Telescope the boom back fully, and take up slack with the winch until the jib mount bracket is aligned with the jib mounts. Install spacers (8), retainers (7), lockwashers (6), and capscrews (5).

7. Install pin (10) and lock it in place with cotter pin (9).

8. Unhook the winch line from becket (4) and attach the line to the hook block.

9. Remove "T" pins from boom jib pivot point and install in stowed position.

## MANUAL FLY SECTION

This machine can be equipped with an optional manually operated fly section which will increase the maximum boom length to 100 feet (30.48 m).

The manual fly section is stored within the telescoping boom, and is extended by means of boom section 2 telescoping cylinder, as described below. To extend the manual fly section, proceed as follows (see Figure 2-18):

**CAUTION**

The crane boom must be in a horizontal position while the manual fly section is being extended or retracted. If this is not observed, it is possible that the fly section could move when the cylinder pin is removed, and cause damage to other parts of the boom.

1. Extend the boom sections until boom section 2 is out approximately 48 inches (1219 mm) and the cylinder pin is visible, as shown in View A.

2. Install the boom stop as shown in View B

3. Remove the cylinder pin end caps.

4. Center the cylinder pin in the manual fly section. Extend the boom until the second hole in the manual fly action is aligned with the hole in boom section 2.

5. Remove the cylinder pin. Retract the telescope cylinder until the cylinder rod eye is aligned with the hole in boom section 2.

6. Install the cylinder pin so that it passes through boom section 2, the second hole in the manual fly section, and cylinder rod eye. Install the cylinder pin end caps.

7. Remove the boom stop. The boom can now be operated as it would normally be operated.

**WARNING**

The machine must not be operated with the telescope cylinder pinned only to the manual fly section. The telescope cylinder must be retracted and pinned to boom section 2 as shown in Section A-A.

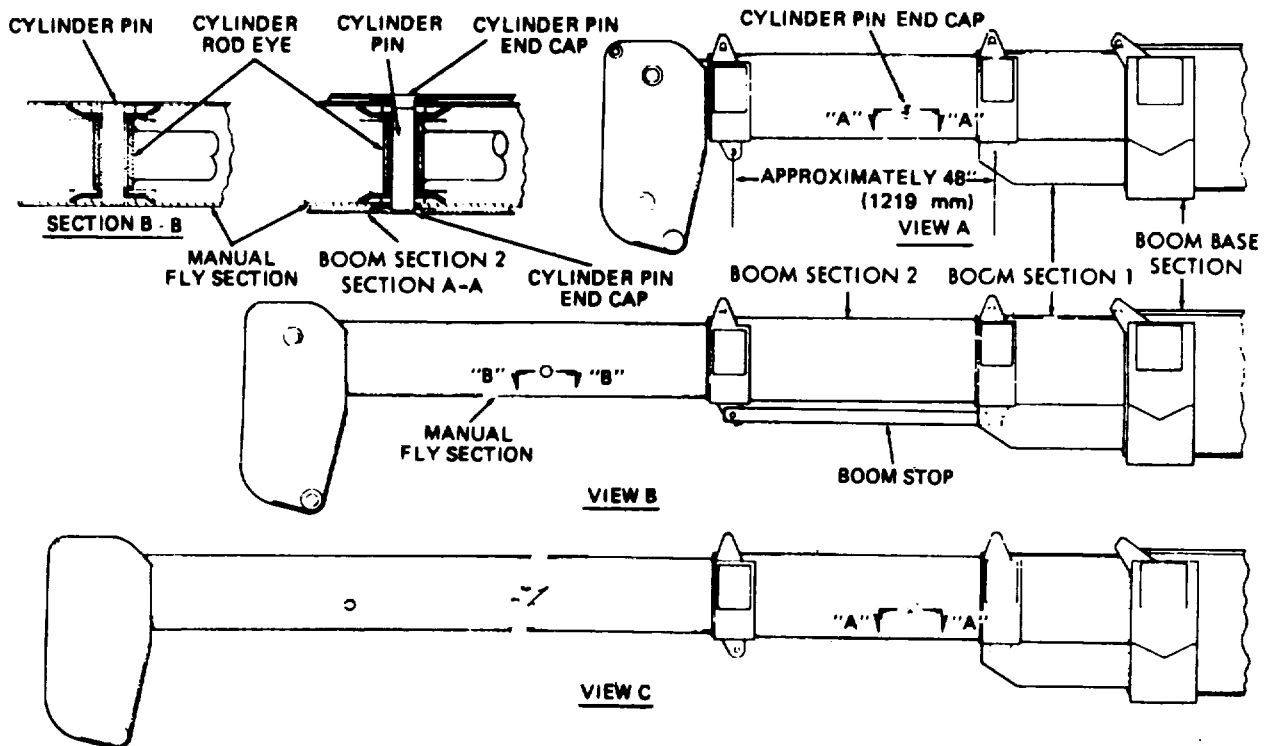

Figure 2-18. Manual Fly Section (105JB81)



## SECTION II

## CONTROLS AND OPERATION

To retract the manual fly section back to the storage position, proceed as follows:

1. Install the boom stop as shown in View B.
2. Remove the cylinder pin end caps and cylinder pin. Extend the telescope cylinder until the cylinder rod eye is aligned with the hole nearest the tip of the manual fly section.
3. Install the cylinder pin in the cylinder rod eye as shown in Section 8-8. Retract the telescope cylinder until the cylinder pin is aligned with the hole in boom section 2.
4. Push the cylinder pin toward the left side of the machine so that it engage boom section 2. Then install the cylinder pin end caps (see Section A-A).
5. Remove the boom stop.

### COUNTERWEIGHT

The counterweight on this machine is attached to the rear of the revolving frame, and can be removed, when necessary, as described below:

1. Rotate the upper so that the boom is over either side of the carrier.
2. Reeve the auxiliary winch line as shown in Figure 2-19 and dead end the cable by means of the cable socket to the bottom of the winch platform.
3. Loosen the counterweight hold down screws.
4. Take up on the auxiliary winch line slightly to relieve the weight on the counterweight pins. Remove the cotter pins in the counterweight pins, and remove the counterweight pins.
5. Pay out the auxiliary winch line to lower the counterweight to the ground.
6. The counterweight can now be lifted onto a truck using the main winch line.

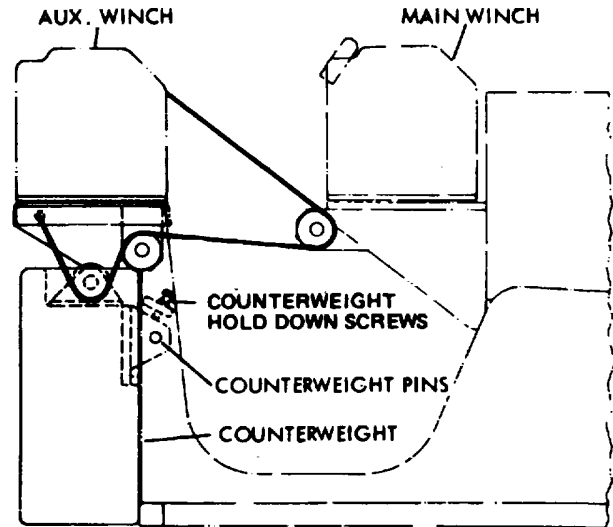

Figure 2-19. Counterweight Removal (100N2382)

### CAUTION

**Be sure that the boom sections are retracted fully before lifting the counterweight.**

Installation and operation of self powered pile driver hammer (NSN 3895-00-014-0583). Refer to TM 5-3895265-14.

### TOWING

Should it become necessary to tow this machine to a repair facility, the propeller shaft between the auxiliary transmission and the front rear axle must be disconnected. If the propeller shaft is not removed, the transmission could be damaged due to inadequate lubrication of the internal gear train while the machine is being towed.

Towing cables or chains, of adequate length, should be attached to the two towing eye located behind the front bumper.

### SECTION III LUBRICATION

#### GENERAL

To insure proper operation of this machine, all points requiring lubrication must be serviced with the correct lubricant, at the proper time interval. All normal wear points which require lubrication are shown in the lubrication charts at the rear of this portion of the manual, with the possible exception of that lubrication information concerning purchased components. For information concerning the lubrication of purchased major components not manufactured by Harnischfeger Corporation, see the manufacturer's manual. Note that the original manufacturer's recommendations take precedence over lubrication recommendations contained in this manual if any conflict exists.

Points not considered to be normal wear points (levers, linkages, pins, and so forth) should be lubricated with an oil can once a week. Use a few drops of engine oil on each exposed pin or lever not equipped with grease fittings to prevent rust and to provide the limited lubrication required.

#### NOTE

**The lubrication recommended in this manual is based on operation of the machine for a period not to exceed eight hours per day, five days per week. If a machine is operated in excess of the above time per day or week, lubrication schedules must be adjusted accordingly.**

All attachment fittings, whether illustrated on the lubrication chart or not, must be lubricated with multipurpose grease every 8 hours.

#### CAUTION

**Initial factory fill of MPG is of the soap base 12-Hydroxy Lithium Stearate type. Other soap base greases are not always compatible with initial fill lubricant, and Barium base grease is definitely not compatible. Various other soap base greases may be used if experience by the purchaser has**

**shown these greases to be acceptable for the application. The grease systems must be thoroughly purged and the affected parts removed and cleaned before switching from a grease having one type of base to a grease having a different soap base.**

#### LUBRICANT SPECIFICATIONS

The following list will identify suitable lubricants for points shown in the lubrication charts by three methods. They are:

1. BY P&H SPECIFICATION NUMBER. This lubricant specification identifies the initial fill lubricant as classified by internal Harnischfeger Corporation Standards.
2. BY MILITARY SPECIFICATION NUMBER. If the lubricant classified by P&H Specification Number has a known military specification equivalent number, this equivalent number is also listed in the individual lubricant description.

#### NOTE

**The absence of an entry in the Military Specification Column in a lubricant description does not mean that the lubricant recommended does not meet any equivalent military specification. It may mean, for instance, that the lubricant has not been tested and qualified by the military because it is relatively new. For that reason, it is not certified as meeting the standards of a particular military specification, even though it may be perfectly capable of so doing.**

3. BY EQUIVALENT LUBRICANT. Equivalent lubricants presently confirmed as meeting the requirements of the P&H specification are listed by trade names. The absence of a lubricant from this list does not mean that it is unsuitable. It means only that, as of the date of this writing, the lubricant has not been tested by P&H. The order in which the lubricants appear on any list is of no significance. No superiority of any brand listed should be read into the order of appearance on a list. The listing is purely random and all products on the list are equally acceptable.

## MULTIPURPOSE GREASE

SYMBOL	P&H SPEC. NO.	AMBIENT RANGE	MILITARY SPEC. NO.	EQUIVALENT LUBRICANTS	MANUFACTURERS
MPG	472A (NLGI #0 EP)	*Below -10°F (-12°C.)	MIL-L-7645 MIL-G-10924 MIL-G-23827 MIL-G-2349 MIL-G-81827	Litholine Industrial 0 EP "Sinclair"  Conolith EP #0  Rolubricant 0  Mobilux EP #0 Alvania EPRO Prestige EP #0 Multifak EP #0	Atlantic Richfield Oil Co.  Continental Oil Company Humble Oil and Refining Company  Mobil Oil Corporation Shell Oil Company Sun Oil Co. – DX Division Texaco, Incorporated
MPG	472B (NLGI #1 EP)	*-20 to +40°F. (-29 to 4°C.)	MIL-L-7645 MIL-G-10924 MIL-G-23827 MIL-G-2349 MIL-G-81827	Amolith No. 1 EP  Litholine Industrial 1 EP "Sinclair"  Conolith EP #1  Rolubricant 1  Mobilux EP #1 Alvania EP #1 Prestige EP #1 Multifak EP #1	American Oil Company  Atlantic Richfield Company  Continental Oil Company Humble Oil and Refining Company  Mobil Oil Corporation Shell Oil Company Sun Oil Co. – DX Division Texaco, Incorporated
MPG	472C (NLGI #2 EP)	*+20 to 125°F. (-6 to 52°C.)	MIL-L-7645 MIL-G-10924 MIL-G-23827 MIL-G-2349 MIL-G-81827	Amolith No. 2 EP  Litholine EP Moly "Sinclair"  Conolith EP #2  Rolubricant 2  Mobilux EP #2 Alvania EP #2 All Purpose EP #2 Multifak EP #2	American Oil Company  Atlantic Richfield Company  Continental Oil Company Humble Oil and Refining Company  Mobil Oil Corporation Shell Oil Company Sun Oil Company Texaco, Incorporated

\*Pumpability tests also required when used in centralized lubrication systems. Consult manufacturer of system.

## PETROLEUM GEAR OIL

SYMBOL	P&H SPEC. NO.	AMBIENT RANGE	MILITARY SPEC. NO.	EQUIVALENT LUBRICANTS	SAE GRADE	MANUFACTURER
GO	497A	Varies, depending on use. See the Lubrication Chart	MIL-L-2105B MIL-L-2109 MIL-L-10295 MIL-L-45199	Multipurpose Gear Lube Ultragear Oil and Extra Duty Gear Lube "Sinclair" Conoco Universal Gear Lubricant Enco Gear Oils GX Mobilube HD Spirax Heavy Duty DX Geartran HD Multigear Lubricant	80 80 80 80 80 80 80 80	American Oil Company Atlantic Richfield Company Continental Oil Company Humble Oil & Refining Company Mobil Oil Corporation Shell Oil Company Sun Oil Company – DX Division Texaco, Incorporated
GO	497B	Varies, depending on use See the Lubrication Chart	See above.	NOTE: Equivalent lubricants and manufacturers are the same as for P&H Spec 497A Petroleum Gear Oil as described above. The only difference, insofar as this description is concerned, is that P&H Specification 497B is an SAE 90 grade lubricant.		
GO	497C	Varies, depending on use See the Lubrication Chart	See above.	NOTE: Equivalent lubricants and manufacturers are the same as for P&H Spec 497A Petroleum Gear Oil as described above. The only difference, insofar as this description is concerned is that P&H Specification 497C is an SAE 140 grade lubricant.		

## HYDRAULIC BRAKE FLUID

SYMBOL	P&H SPEC. NO.	AMBIENT RANGE	MILITARY SPEC. NO.	EQUIVALENT FLUIDS	MANUFACTURER
HBF	492	Not applicable	VV-B-680 (latest issue)	21B Brake Fluid Formula H-68  UCON Brake Fluid 4823	Wagner Electric Corporation  Union Carbide Corporation

## POWER TRANSMISSION FLUID AND GEAR OIL

SYMBOL	P&H SPEC. NO.	MILITARY SPEC. NO.	EQUIVALENT LUBRICANTS	MANUFACTURER
ATF	494	None Assigned	Dexron ® Enco ATF Mobil ATF 220 Shell Donax T-6 DX ATF Dexron ® Texamatic Fluid 6673 ATF-Dexron ® American Dexron ® ATF	Continental Oil Company Humble Oil and Refining Mobil Oil Corporation Shell Oil Company Sun Oil Company - DX Division Texaco, Incorporated Sinclair Refining Company American Oil Company
NOTE: This specification covers a petroleum power transmission fluid and lubricating oil properly described as Dexron ® fluid.				

## OPEN GEAR AND WIRE ROPE LUBRICANT

SYMBOL	P&H SPEC. NO.	AMBIENT RANGE (or application)	MILITARY SPEC. NO.	EQUIVALENT LUBRICANTS	SAE GRADE	MANUFACTURER
GL	464	Open gears and racks under varying weather conditions. Peripheral speeds not to exceed 1200 feet per minute (365.8 m/min.)	VV-L-751C,	Amovis Lubricant and Amoco Open Gear Comp'd.	*	American Oil Company
			VV-L-751C,	Richcote Lubricant, Jet Lubricants "Sinclair", and Atlantic Lubricants 36 thru 40	*	Atlantic Richfield Company
			Type 1, Regular	Coglube	*	Continental Oil Company
			Grade 1 - Light	Surett	*	Humble Oil & Refining Company
			Grade 2 - Medium	Mobitac	*	Mobil Oil Corporation
			Grade 3 - Heavy	Cardium EP Com'ds & Fluids	*	Shell Oil Company
			MIL-L-43914,	DX Coating Compounds	*	Sun Oil Co. DX Division
			Grade 1	Crater X	*	Texaco, Inc.
				Open Gear, Dipper Stick, and Cam Lube	*	Whitmore Mfg. Co.

\*Consult lubricant manufacturer for proper viscosity grade, which will depend on application and climate.

## HEAVY DUTY MOTOR OIL

SYMBOL	P&H SPEC. NO.	AMBIENT RANGE	MILITARY SPEC. NO.	EQUIVALENT LUBRICANTS	SAE GRADE	MANUFACTURER
MO	451A	See Lubrication Chart	MIL-L-2104B (or latest issue in effect)	Conoco Tracon Encolube Delvac 1200 Series Rotella T Oils TBD Mil B Motor Oil Ursa Oils – Extra Duty Super Tenol Amoco 200 Motor Oils	SAE 10W " " " " " " "	Continental Oil Company Humble Oil & Refining Co. Mobil Oil Corporation Shell Oil Company Sun Oil Co. – DX Division Texaco, Inc. Sinclair Refining Company American Oil Company
MO	451B	See Lubrication Chart	MIL-L-2104B (or latest issue in effect)	NOTE: Equivalent lubricants and manufacturers are the same as for P&H Spec. 451A Motor Oil as described above. The only difference, insofar as this description is concerned, is that P&H Specification 451B is an SAE 20-20W grade oil.		
MO	451C	See Lubrication Chart	MIL-L-2104B (or latest issue in effect)	NOTE: Equivalent lubricants and manufacturers are the same as for P&H Spec. 451A Motor Oil as described above. The only difference, insofar as this description is concerned, is that P&H Specification 451C is an SAE 30 grade oil.		
MO	451D	See Lubrication Chart	MIL-L-2104B (or latest issue in effect)	NOTE: Equivalent lubricants and manufacturers are the same as for P&H Spec. 451A Motor Oil as described above. The only difference, insofar as this description is concerned, is that P&H Specification 451D is an SAE 40 grade oil.		
MO	451E	See Lubrication Chart	MIL-L-2104B (or latest issue in effect)	NOTE: Equivalent lubricants and manufactureres are the same as for P&H Spec. 451A Motor Oil as described above. The only difference, insofar as this description is concerned, is that P&H Specification 451E is an SAE 50 grade oil.		

## HYDRAULIC OIL

SYMBOL	P&H SPEC. NO.	AMBIENT RANGE	MILITARY SPEC. NO.	EQUIVALENT LUBRICANTS	SAE GRADE	MANUFACTURER
HO	484S	-10° to +65° F (-23 to 18° C.)	Not Available	Alubco Hydraulic Oil-Medium	SAE 10	The American Lubricants Company
				Amoco AW 15	"	American Oil Company
				B.P. Energo SHF 60	"	B.P. North America Inc. (International)
				Citco Extra Duty Circulating Oil #42	"	Cities Service Oil Company
				Conoco Super Hydraulic Oil #15	"	Continental Oil Company
				Gulf Harmony 43 AW	"	Gulf Oil Company
				Nuto H 44	"	Humble Oil Company (Exxon) and Imperial Esso of Canada
				Molub-Alloy Hydraulic Oil #771	"	Imperial Oil and Grease Company
				DTE #24 Hydraulic Oil	"	Mobil Oil Company
				Lo Hydraul #27	"	Shell Oil Company
				Chevron EP Hydraulic Oil #9	"	Standard Oil of California
				Industron #44	"	Standard Oil of Ohio (S. Ohio)
				Rando Oil HD-A	"	Texaco
				Union Unax AW #150	"	Union Oil Company of California (Union 76)
HO	484T	Above +65° F (Above 18° C.)	Not Available	Alubco Moly Hydraulic Oil Medium	SAE 20	The American Lubricants Company
				Amoco AW 21	"	American Oil Company
				Citco Extra-Duty Circulating Oil #48	"	Cities Service Oil Company
				Super Hydraulic #21	"	Continental Oil Company
				Harmony 48 AW	"	Gulf Oil Company
				Nuto H 48	"	Humble Oil Company (Exxon) and Imperial Oil Company (Esso)
				Molub-Alloy Hydraulic Oil #772	"	Imperial Oil and Grease Company
				DTE 25 Hydraulic #29	"	Mobil Oil Company
				Chevron EP Hydraulic Oil #11	"	Shell Oil Company
				Industron 48	"	Standard Oil Company of California (Chevron)
				Sunvis 821 WR	"	Standard of Company of Ohio (Sohio)
				Rando Oil HD-B	"	Sun Oil Company
				Union Unax AW 215	"	Texaco
					"	Union Oil Company of California (Union 76)



## HIGH TEMPERATURE GREASE

SYMBOL	P&H SPEC. NO.	AMBIENT RANGE	MILITARY SPEC. NO.	EQUIVALENT LUBRICANTS	MANUFACTURERS
HTG	476	(working temperature range) 0°F to +450° (-21 to 232° C.)	Not available	Shell Darina No. 2 E.P.	Shell Oil Company

Note: The above lubricant is the only one currently approved as meeting P&H Specification No. 476. It is Shell Oil Code Number 71522. This is a special grease which shows high thermal stability and resistance to shock loading and adverse chemical environmental conditions. It is used as a replacement for P&H 472 MPG when reversing service, long life, or high temperature operation demands this premium lubricant.

**SECTION IV  
PREVENTIVE MAINTENANCE****GENERAL**

Preventive maintenance is the easiest and least expensive type of maintenance. It permits the Maintenance Department to do the work at a convenient time.

The actual operating environment of the machine governs the maintenance schedule. The suggested check sheet on the following page indicates the areas of the machine to be checked and the intervals at which they should be checked.

**NOTE**

**The following suggested check sheet is based on average operating conditions. The type of work being done, size of loads, and ground and weather conditions are all factors which must be considered when establishing a maintenance schedule for your machine. The suggested schedule basis is given for hours of operation and calendar intervals.**

Any change in the established maintenance schedule should be preceded by a complete re-analysis of the

machine operation. Carefully study previous maintenance check sheets and records before making any changes in, or extending, the check intervals.

**USING THE SUGGESTED SCHEDULE CHECK SHEET**

The maintenance schedule check sheet is designed as a preventive maintenance guide, until adequate experience is obtained to establish a schedule to meet a specific operating environment.

Following the check sheet are detailed procedures, grouped in check intervals, describing the procedure that should be used to perform the check sheet operations.

The check sheet shown can be reproduced by any printer to obtain additional copies of the check sheet. The maintenance man making each check can then indicate on the sheet that the required check has been completed. When a check has been completed, the machine will be ready for additional service until the next check is due.

## SECTION IV

## PREVENTIVE MAINTENANCE

A-Check Daily	B-Check Weekly-40 hours	C-Check Monthly-160 hours	D-Check Quarterly-500 hours	E-Check Semi-Annually-1000 hrs.
<input type="checkbox"/> Perform daily lubrication  <input type="checkbox"/> Fill fuel tank  <input type="checkbox"/> Check engine oil level  <input type="checkbox"/> Check coolant level  <input type="checkbox"/> Check hydraulic oil tank level  <input type="checkbox"/> Drain air tanks  <input type="checkbox"/> Inspect wire rope for damage  <input type="checkbox"/> Check machine for leaks & damage	<input type="checkbox"/> Repeat A check  <input type="checkbox"/> Perform weekly lubrication  <input type="checkbox"/> Check battery electrolyte level  <input type="checkbox"/> Check swing reducer oil level  <input type="checkbox"/> Check air cleaner  <input type="checkbox"/> Check axle oil levels  <input type="checkbox"/> Check main transmission oil level  <input type="checkbox"/> Check auxiliary transmission oil level  <input type="checkbox"/> Check tires  <input type="checkbox"/> Check air tank safety valve	<input type="checkbox"/> Repeat A&B check  <input type="checkbox"/> Perform monthly lubrication  <input type="checkbox"/> Change engine oil & oil filter  <input type="checkbox"/> Change fuel filter elements  <input type="checkbox"/> Change hydraulic oil filter  <input type="checkbox"/> Check engine belts  <input type="checkbox"/> Check brake adjustment  <input type="checkbox"/> Check hoses & tubing for leaks & damage  <input type="checkbox"/> Check winch oil levels  <input type="checkbox"/> Check slewing ring bolt torque  <input type="checkbox"/> Check pump drive oil level  <input type="checkbox"/> Check clutch oil level	<input type="checkbox"/> Repeat A, B, & C check  <input type="checkbox"/> Perform quarterly lubrication  <input type="checkbox"/> Drain sediment & water from fuel tank  <input type="checkbox"/> Check condition of cooling system hoses  <input type="checkbox"/> Check air valves & cylinders for leaks  <input type="checkbox"/> Clean steering/outrigger filter  <input type="checkbox"/> Check clutch adjustment	<input type="checkbox"/> Repeat A, B, C, & D check  <input type="checkbox"/> Clean crankcase breather  <input type="checkbox"/> Inspect & clean blower screen  <input type="checkbox"/> Clean cooling system  <input type="checkbox"/> Clean exterior of radiator  <input type="checkbox"/> Clean hydraulic tank breather  <input type="checkbox"/> Change axle oil  <input type="checkbox"/> Change main transmission oil  <input type="checkbox"/> Change Auxiliary transmission oil  <input type="checkbox"/> Service quick start

The information on this check sheet is intended to *supplement* the original equipment manufacturer's recommendations. Refer to the equipment manufacturer's manual for additional recommendations. If a conflict exists between this check sheet and the equipment manufacturer's manual, the equipment manufacturer's manual takes *precedence*.

'A' Maintenance Checks
------------------------

**PERFORM DAILY LUBRICATION**

Refer to the lubrication charts, in Section III of this manual, and lubricate all the daily lubrication points indicated with the type of lubricant specified.

**FILL FUEL TANK**

The fuel tank is located under the deck plates on the left side of the carrier, behind the operator's cab. The filler cap is protected by a cover hinged to the deck plates.

The fuel tank should be kept as full as possible, with a quality grade of No. 2 Diesel Fuel, to minimize condensation. The fuel tank has a capacity of 70 gallons (265 l).

**CHECK ENGINE OIL LEVEL**

Check the oil level using the dipstick located at the left, rear corner of the engine. For accurate readings, the oil level *should not* be checked for approximately 15 minutes after shutting down the engine. Maintain the oil level as near the "F" (full) mark as possible at all times (see Figure 4-1).

**CAUTION**

**Never operate the engine with the oil level below the "L" (low) mark or above the "F" (full) mark.**

If necessary, add oil of the type specified in Section III of this manual to bring the oil to the proper level.

**CHECK COOLANT LEVEL**

Check the engine radiator coolant level, and add water or antifreeze as required. Use the type and amount of anti-freeze recommended by the engine manufacturer for the prevailing temperature.

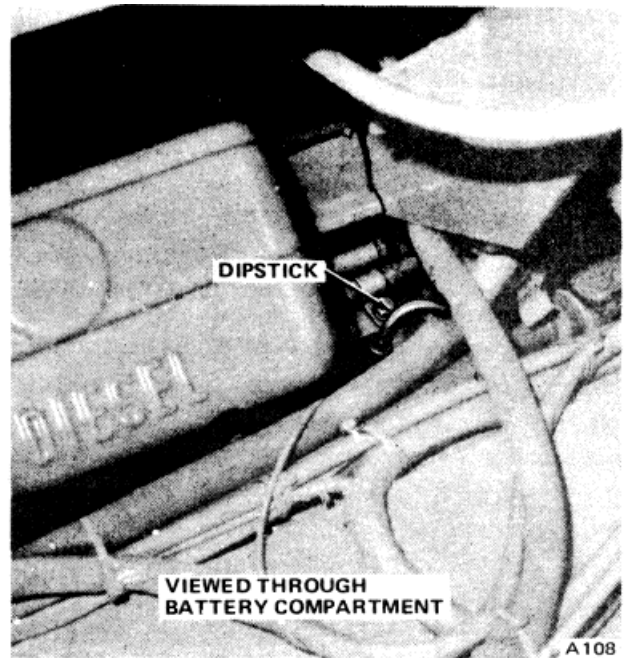

Figure 4-1. Checking Engine Oil Level

**CHECK HYDRAULIC OIL TANK LEVEL**

Check the oil level in the hydraulic tank, as follows (see Figure 4-2):

1. Retract all telescoping boom sections, lower the boom onto the boom rest, and raise the outriggers to the stored position. Be sure the machine is on level ground.
2. Remove the dipstick from the hydraulic tank and note the level of the oil. The oil level should be up to the mark on the dipstick. If necessary, add hydraulic oil of the type specified in Section III, to bring the oil to the proper level through the filler opening.

**CAUTION**

**Never add hydraulic oil to the tank through the dipstick opening.**

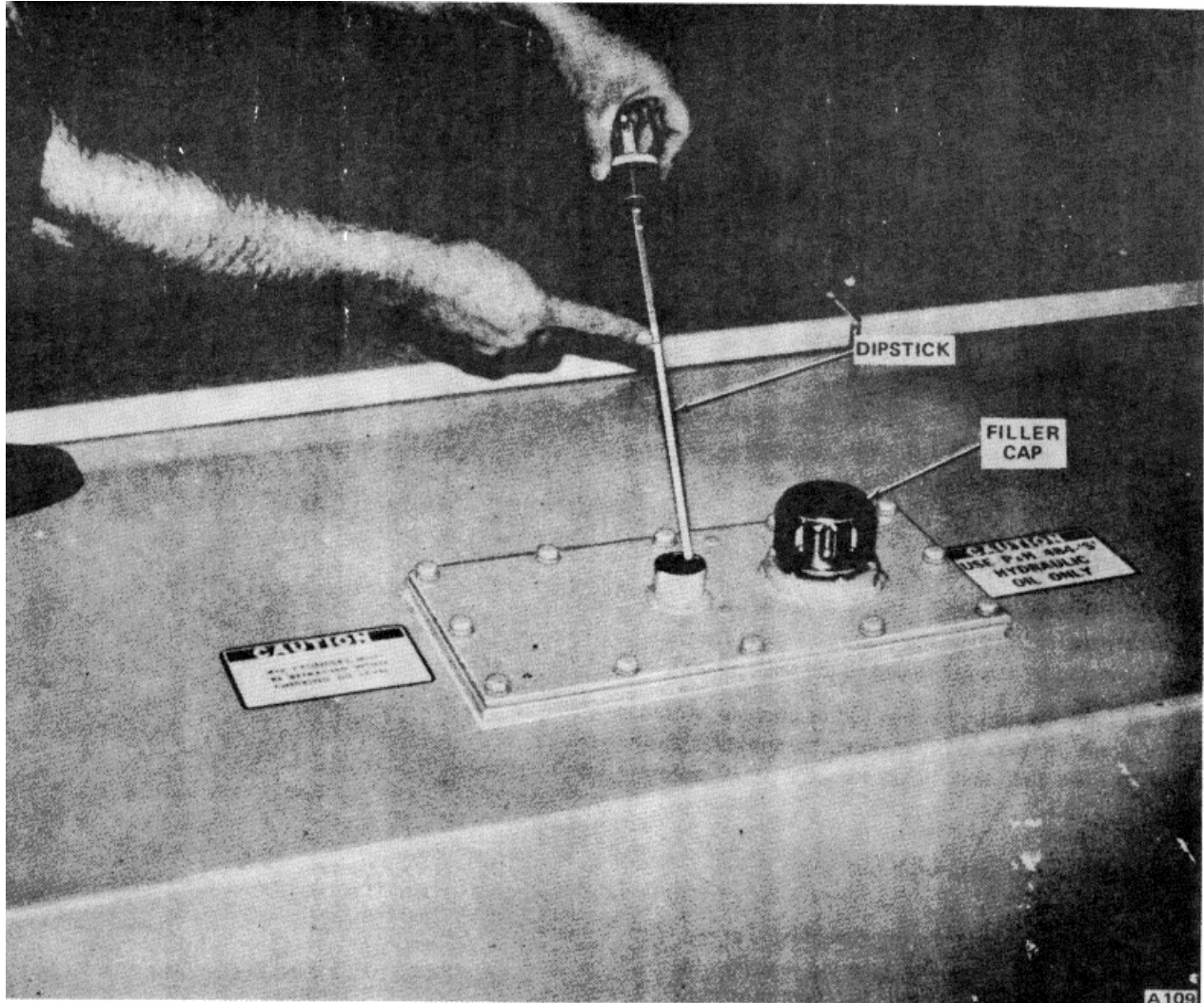

Figure 4-2. Hydraulic Oil Level

#### **DRAIN AIR TANKS**

Open the drain cock on the bottom of each air tank daily, or as frequently as is found necessary, to blow out moisture and accumulated sediment.

#### **INSPECT WIRE ROPE FOR DAMAGE**

Inspect the wire rope, wire rope sockets, and any other wire rope fitting for damage. A wire rope inspection form has been provided at the end of this maintenance check to assist the inspector.

If damaged components are found, they should be replaced or repaired before the machine is placed in service.

#### **CHECK MACHINE FOR LEAKS AND DAMAGE**

Make a *complete* visual inspection of the entire machine, looking for leaks, loose connection, or any other unsafe condition. Repair or replace any faults which are found before placing the machine in service.

**'B' Maintenance Checks**

At each "B" Maintenance Check, perform all "A" Checks in addition to the following.

**PERFORM WEEKLY LUBRICATION**

Refer to the lubrication charts, in Section III of this manual, and lubricate all the weekly lubrication points indicated with the type of lubricant specified.

**CHECK BATTERY ELECTROLYTE LEVEL**

The battery is located in the compartment just behind the carrier cab.

Check the battery water level, and add distilled water as necessary to maintain the water level  $\frac{3}{8}$  inch (9.2 mm) above the plates. Clean any corrosion and/or dirt from the battery and terminals.

**CHECK SWING REDUCER OIL LEVEL**

Remove the filler plug from the swing reducer to check the level of the oil in the reducer. The oil should be just up to the bottom of the filler opening. If the oil is not at the proper level, add oil of the type specified in Section III as required to bring the oil to the proper level (see Figure 4-3).

**CHECK AIR CLEANER**

Air cleaner filter cartridge changes can be scheduled, but due to wide variations in dust and weather conditions, even in the same location, changing "as required" is usually more economical.

Until sufficient experience is gained, however, to determine the "as required" change interval, the air cleaner should be checked weekly.

**NOTE**

**Loss of engine power or excessive smoke in exhaust gases are indications that the filter cartridge is clogged and requires changing.**

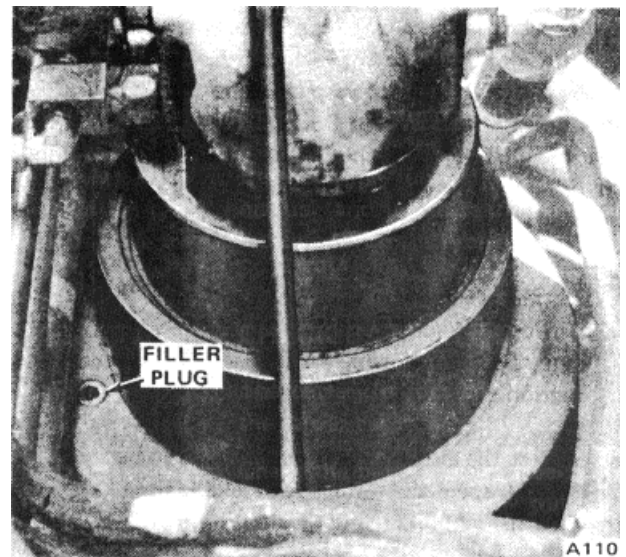

Figure 4-3. Swing Reducer Filler Plug

To replace the filter cartridge, proceed as follows (see Figure 4-4):

1. Remove the four clamps which hold the moisture eliminator in place, and remove the moisture eliminator.

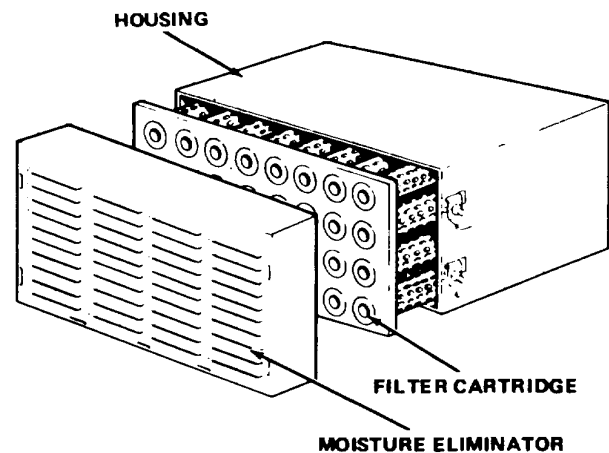

Figure 4-4. Engine Air Cleaner

## SECTION IV

## PREVENTIVE MAINTENANCE

2. Remove the dirty filter cartridge by inserting fingers in the cartridge openings. Loosen all four corners of the cartridge, one at a time, by pulling straight out.

3. Clean the moisture eliminator openings of all soot, oil film, and any other objects that may have become lodged in the openings. Inspect the inside of the air cleaner housing for foreign material.

4. Inspect the dirty cartridge for soot or oil. If there is soot inside the tubes, check for leaks in the engine exhaust system. If the cartridge appears "oily", check for fumes escaping from the crankcase breather. Excessive oil mist shortens the life of the cartridge. Troubleshooting at this point can appreciably lengthen new cartridge life.

### NOTE

**It is not recommended to clean and reuse the filter cartridge. When returned to service, the life expectancy of a paper cartridge will be only a fraction of the original service life.**

5. Inspect the air cleaner mounting bolts to be sure they are tight. Inspect the clamps and flexible hose to be sure they are air tight and in good condition.

6. Install a new cartridge, hold the cartridge in the same manner as when removing it from the housing. Insert the clean cartridge into the housing; avoid hitting the cartridge tubes against the sealing flange of the housing.

### CAUTION

**Since the air cleaner requires no separate gaskets or seals, care must be taken when inserting a new cartridge to insure a proper seat within the housing. Firmly press all edges and corners of the cartridge by hand to effect a positive air seal against the sealing flange in the housing. Under no circumstances should the cartridge be pounded or pressed in the center with a fist to effect a seal.**

7. Replace the moisture eliminator panel and tighten the clamps by hand. Then turn the nuts an additional 1-1/2 to 2 turns with a small adjustable wrench. Do not overtighten.

### CHECK AXLE OIL LEVEL

Remove the combined filler-level plug from the side of the differential carrier to check the oil level of these units. The oil should be just up to the bottom of the level opening. Be sure the machine is level when checking the oil level (see Figure 4-5).

If oil is added to the axles, allow sufficient time for any excess oil to run out before installing the filler-level plug. Under no circumstances should the differential be overfilled.

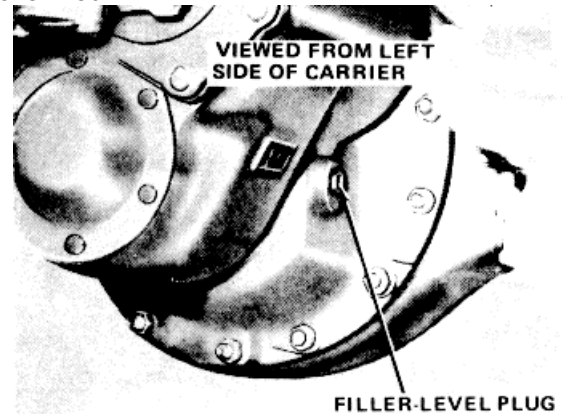

A111

Figure 4-5. Differential Oil Level Plug

### CHECK MAIN TRANSMISSION OIL LEVEL

Clean the area around the filler-level plug, and remove the plug (see Figure 4-6). The oil in the main transmission should be just up to the bottom of the opening. Be sure the machine is level when checking the oil level.

If oil is added to the transmission, allow sufficient time for any excess oil to run out before installing the filler-level plug. Do not overfill the transmission.

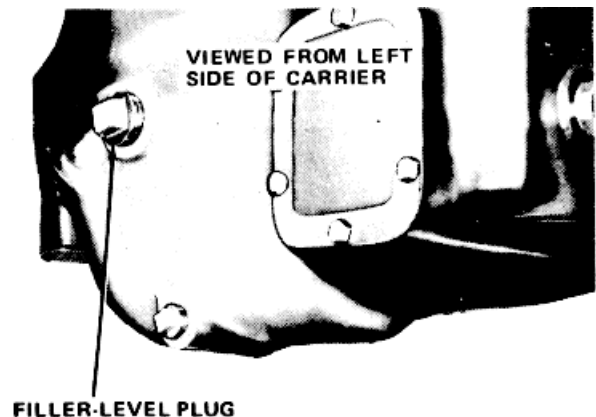

A112

Figure 4-6. Main Transmission Oil Level Plug

**CHECK AUXILIARY TRANSMISSION OIL LEVEL**

Clean the area around the filler-level plug, and remove the plug (see Figure 4-7). The oil in the auxiliary transmission should be just up to the bottom of the plug opening. Be sure the machine is level when checking the oil level.

If oil is added to the auxiliary transmission, allow sufficient time for any excess oil to run out before installing the filler-level plug. Do not overfill the transmission.

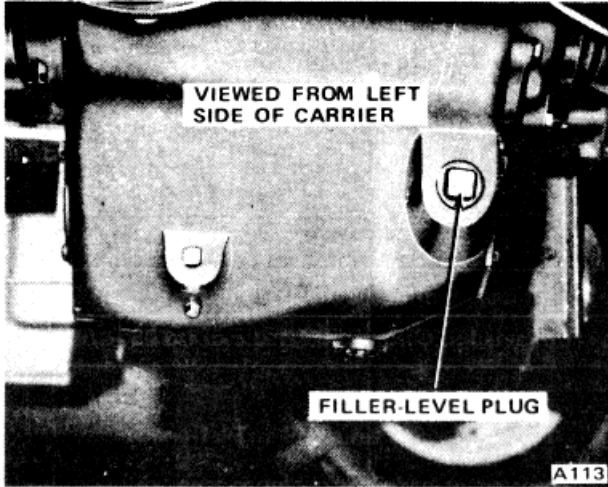

Figure 4-7. Auxiliary Transmission Oil Level Plug

**CHECK TIRES**

Each week, check the tires for cuts, bruises, snags, punctures, and abrasions. These minor injuries if neglected will cause tire failures. If these injuries are spotted in time, they can be repaired, and the tires will provide safer and more profitable service life. In addition to checking the tires for damage, check the condition of

the tire valves, and be sure each tire valve is equipped with a valve cap.

The tire rims should be checked to be sure they are not bent, loose, cracked, or otherwise damaged. If any of these conditions exist, the rim must be repaired or replaced.

When tire wear or damage occurs as a result of a mechanical deficiency of the machine, such a deficiency should be corrected immediately.

The tires should be inflated to the pressures shown in Table 4-1, unless otherwise specified in the machine for a specific application. The tires should be adjusted to these pressures when the tires are cool. When the tires are hot from running, the pressure gauge reading should be approximately 15 psi (1 bar) higher due to heat buildup.

TIRE SIZE	ON-HIGHWAY	OFF-HIGHWAY
11:00 X 20	75 psi (5 bars)	85 psi (5.8 bars)
12:00 X 20	80 psi (5.5 bars)	90 psi (6.2 bars)

Table 4-1. Tire Pressures

The wheel mounting nuts should be checked to be sure they are tightened securely.

**CHECK AIR TANK SAFETY VALVE**

At least weekly, manually pull out the stem of the safety valve on the dry tank to insure that the valve is not sticking. If the stem cannot be pulled out, the safety valve should be repaired or replaced.



**'C' Maintenance Checks**

At each "C" Maintenance Check, perform all "A & B" Checks in addition to the following.

**PERFORM MONTHLY LUBRICATION**

Refer to the lubrication charts, in Section III of this manual, and lubricate all the monthly lubrication points indicated with the type of lubricant specified.

**CHANGE ENGINE OIL & OIL FILTER**

The engine oil and filter change interval should be started with a monthly interval. The change interval may then be gradually increased, or decreased, following the recommendations of an independent oil analysis laboratory or the oil supplier (based on the oil sample analysis) until the most practical oil change period for the particular service has been established.

To change the engine oil and filter, proceed as follows (see Figure 4-8): 1. Bring the engine up to operating temperature. Shut down the engine, remove the drain plug from the bottom of the oil pan, and drain the oil into a suitable container.

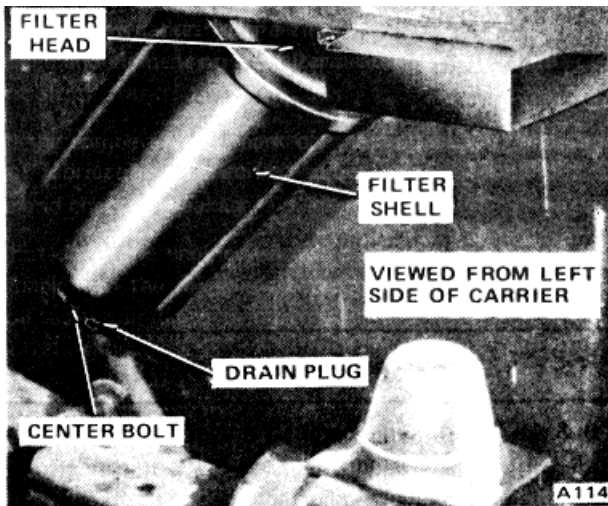

Figure 4-8. Engine Oil Filter

2. Replace the oil pan drain plug and tighten the plug securely.
3. Remove the drain plug from the filter shell and allow it to drain. Replace the drain plug.
4. Loosen the center bolt and remove the filter shell and filter element. Before discarding the filter element, inspect it as follows:
  - A. Inspect for metal particles.
  - B. Inspect the outside wrapper of the element for wrinkles and the pleats for waviness or bunching. Presence of these conditions indicates that the oil contains moisture.
  - C. If the element is relatively clean, it may be possible to lengthen the change interval. If the element is dogged, the change interval should be shortened.
5. Remove the gasket from the filter head and discard it.
6. Clean the filter shell thoroughly with a suitable solvent.
7. Check that the element end seal is in place in the filter shell, and install a new element over the spring support assembly.
8. Install a new gasket in the filter head. Position the filter shell and element on the filter head and tighten the center bolt.
9. Fill the engine to "F" mark on the dipstick with the type of lubricating oil specified in Section III. Run the engine and check for leakage.
10. Shut down the engine. Allow 15 minutes for oil to drain back into the oil pan, and recheck the oil level.

Add oil, as required, to bring the oil level to the "F" mark on the dipstick.

**CHANGE FUEL FILTERS**

New fuel filter should be installed each month or when they become plugged.

## SECTION IV

A method of determining when the elements are plugged to the extent that they should be changed is based on the fuel pressure at the cylinder head fuel inlet manifold and the inlet restriction at the fuel pump. In a clean system, the maximum pump inlet restriction must not exceed 6 inches (152.4 mm) of mercury. At normal operating speeds (1800-2800 rpm) the fuel pressure is 45 to 70 psi (3.1-4.8 bars). Change the fuel filters whenever the inlet restriction (suction) at the fuel pump reaches 12 inches (304.8 mm) of mercury at normal operating speed and whenever the fuel pressure at the inlet manifold drops to 45 psi (3.1 bars).

To replace the fuel filters, proceed as follows (see Figure 4-9): 1. Unscrew the fuel filters and discard them.

2. Fill the new filters with clean fuel.

3. Install the fuel filter. Tighten them by hand until the seal touches the filter head. Then tighten each filter an additional one-half to three-fourths turn.

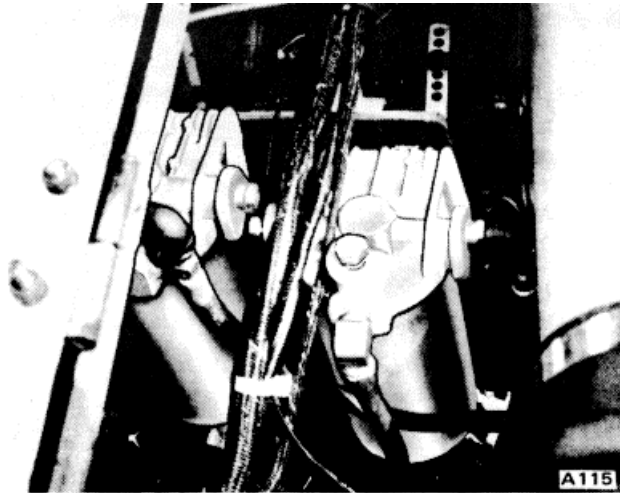

Figure 4-9. Engine Fuel Filters

### CHANGE HYDRAULIC OIL FILTERS

The hydraulic system oil is filtered on the return side by two full flow type filters located at the right rear corner of the engine compartment.

To change the hydraulic oil filter, proceed as follows (see Figure 4-10): 1. Remove the cover above the filters. The cover is held in place by Zeus fasteners.

2. Remove the center bolt and washer from the bottom of the filter.

3. Remove the shell and gasket from the filter head.

## PREVENTIVE MAINTENANCE

4. Before discarding the filter elements, inspect the foreign material trapped in them. The type of material trapped in the filter elements could give an indication of deterioration of some hydraulic system component.

5. Clean the shell thoroughly in a suitable solvent.

6. Install a new gasket in the filter head. Install the new filter element in the shell, position the shell under the filter head, and tighten the center bolt to 30-35 FT-LBS.

(4.15-4.8 m-kg). Run the engine, with the pump drive engaged, several minutes and check for leakage.

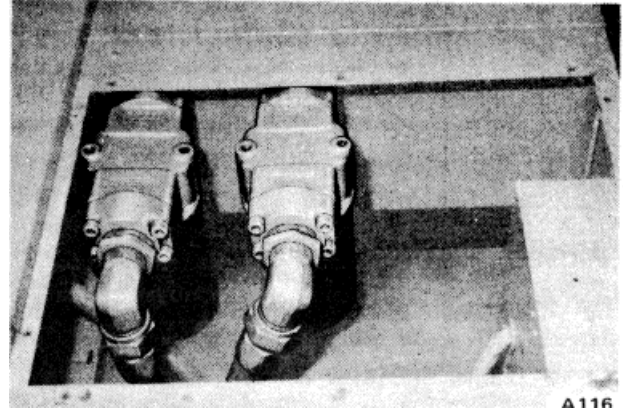

Figure 4-10. Hydraulic Oil Filters

### CHECK ENGINE BELTS

New drive belts will stretch after the first few hours of operation. Retighten the fan drive, water pump drive, and alternator drive belts after the first 8 hours or 240 miles of operation. Thereafter, check the tension of the drive belts monthly and adjust if necessary. Too tight a belt is destructive to the bearings of the driven part; a loose belt will slip.

Replace all belts in a set when one is worn. Single belts of similar size should not be used as a substitute for a matched set, premature belt wear can result because of belt length variation. All belts in a matched set are within .032" (8.1 mm) of their specified center distances.

Adjust the belt tension so that a firm push with the thumb, at a point midway between two pulleys, will depress the belt 1/2" to 3/4" (12.7-19.0 mm).

### CHECK BRAKE ADJUSTMENT

The wheel brakes should be checked, at a monthly interval, to determine the need for adjustment. The rear brakes should be adjusted when the stroke needed to apply the brakes reaches 2-1/4" (57 mm).

If the brakes require adjustment, proceed as follows (see Figure 4-11): 1. Raise the wheels off the ground using the outriggers.

2. Push in the locking sleeve on the slack adjuster, and turn the adjusting screw until the stroke required to apply the brakes is reduced to one inch.

3. Check the adjustment by making several brake applications. The air chamber push rod should move a total of one inch from the released to the applied position.

4. Release the brakes and spin the wheel, by hand, to be sure the brake shoes are not dragging.

The lining to drum clearance of the front brakes should be checked, using a feeler gauge. If the clearance is more than 0.060" (1.5 mm), adjust the brakes manually as described below, and schedule the vehicle for brake service.

1. Jack or hoist the front wheels off the ground.
2. Remove the dust cover from the adjusting slots above and below the brake chambers.
3. The adjusting bolts have right hand treads. Using an adjusting spoon, turn the star wheel until a heavy drag is developed, then back off the star wheel to a very light drag on the drum. Reinstall the dust covers in the adjusting slots.

### CAUTION

Be sure the machine is level, and the boom is in the boom rest before checking the oil in the winch.

### CHECK HOSES AND TUBING

Carefully inspect all hoses and tubing on the machine for leaks and/or damage. Leaks that cannot be stopped by tightening the fitting should be removed and repaired or replaced.

### CHECK WINCH OIL LEVELS

Two makes of hydraulic winches have been used on this machine. Earlier machines were equipped with free-fall and non free-fall type Gearmatic Winches, while later machines are equipped with P&H Winches.

To check the winch oil levels in a P&H Winch, proceed as follows (see Figure 4-12): 1. Remove the cover over the winch brake. Then remove the oil level plug and relief valve. Pour oil, of the type specified in Section III for the Sprag clutch, into the relief valve opening until the oil just runs out of the oil level opening. Replace the oil level plug and relief valve.

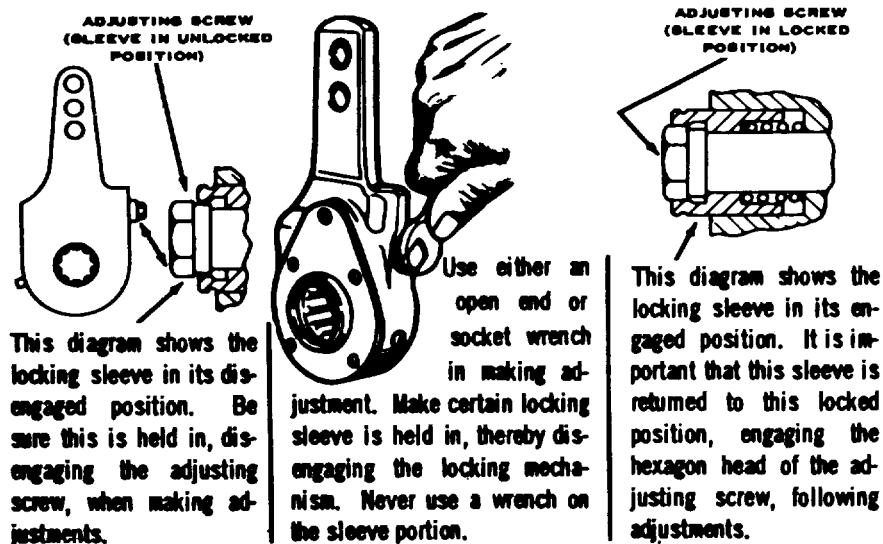

Figure 4-11. Adjusting Positive Slack Adjusters

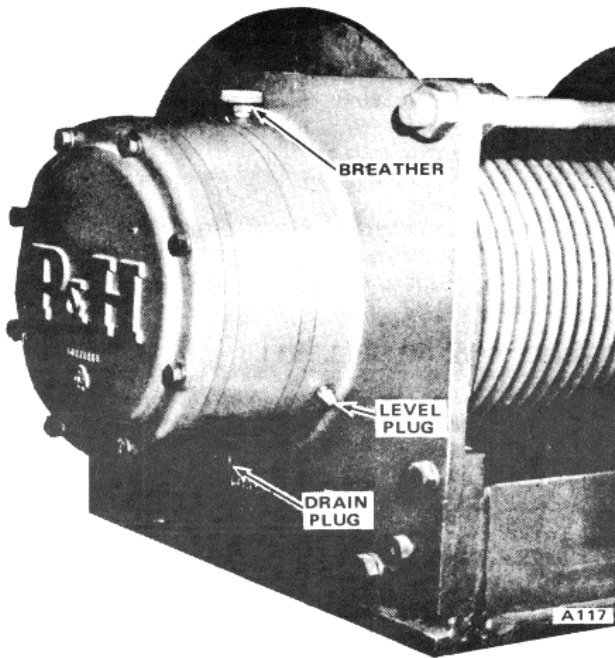

Figure 4-12. Oil Levels - P&H Winch

2. Remove the level plug from the planetary housing.

The oil should be just up to the level plug opening. If the oil is not up to the opening, remove the breather and add oil, of the type specified in Section III for the winch gearing, through the breather opening to bring the oil to the proper level. Replace the breather and oil level plug.

To check the oil level in a Gearmatic Winch, proceed as follows (see Figure 4-13): 1. Non free-fall Gearmatic Winches are equipped with a combination oil level-filler plug on the final drive end of the winch. Remove this plug to check the oil level. The oil should be just up to the opening. Add oil, of the type specified in Section III for the winch gearing, through the oil level-filler opening to bring the oil to the proper level.

2. Free-fall type Gearmatic Winches are continuously lubricated by the hydraulic oil used to operate the winch, and therefore, do not require periodic inspection.

#### CHECK SLEWING RING BOLT TORQUE

The slewing ring mounting bolts should be retorqued after the first 200 hours of operation, and every 200 hours thereafter.

1-4-12 Check the mounting bolts in the interior bolt circle using a suitable torque wrench to be sure that they are

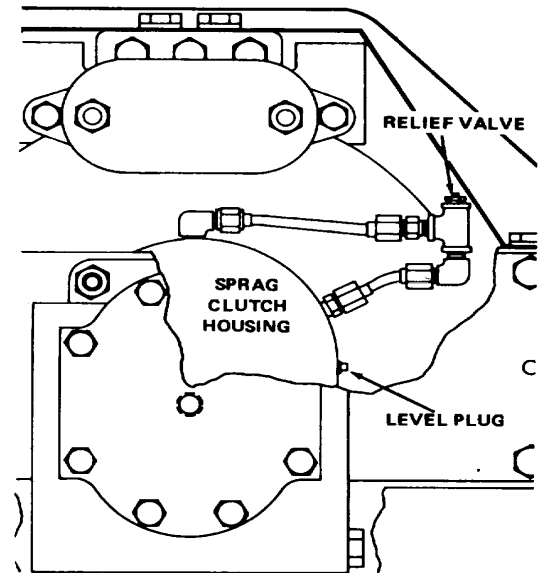

torqued to 550 foot-pounds (76 m-kg). The bolts can be reached by removing the cover from the revolving frame. Slowly swing the upper as required to position the interior mounting bolts under the opening in the revolving frame (see Figure 4-14).

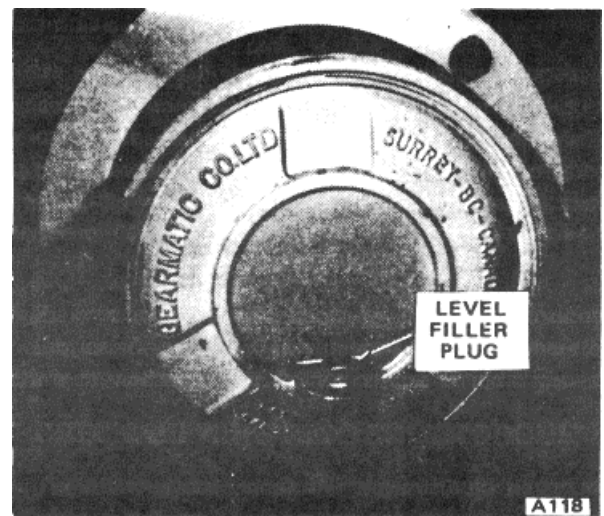

Figure 4-13. Oil Level Plug - Gearmatic Winch

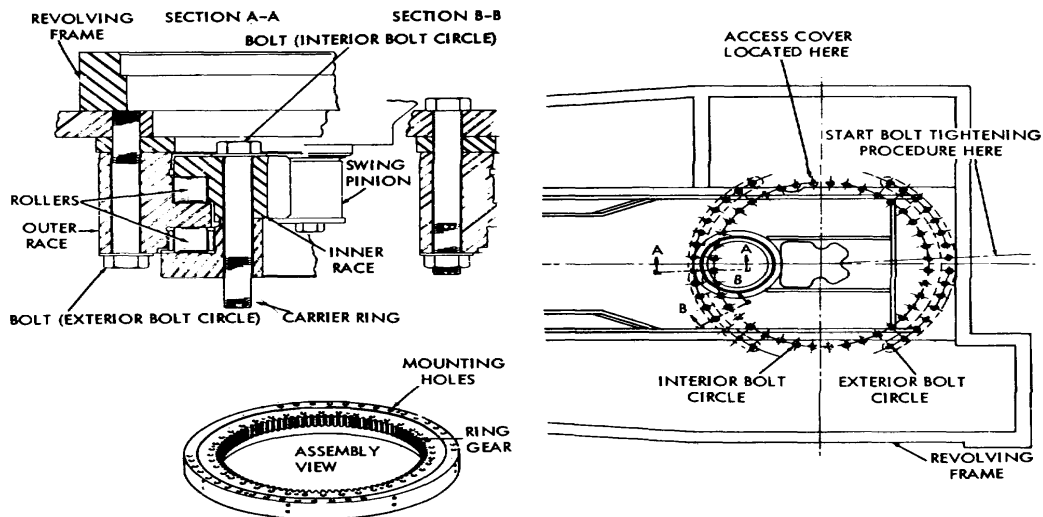

Figure 4-14. Slew Ring

Check the mounting bolts in the exterior bolt circle using a suitable torque wrench to be sure they are torqued to 440 foot-pounds (60.8 m·kg).

#### CHECK PUMP DRIVE OIL LEVEL

Clean the area around the oil level plug, and then remove the oil level plug (see Figure 4-15). The oil in the pump drive should be up to the oil level plug opening. Be sure the machine is level when checking the oil level.

If the oil is not up to the oil level opening, remove the breather at the top of the pump drive, and add oil of the type specified in Section III until the oil reaches the bottom of the oil level plug opening.

Wash the breather in fuel oil and dry it with compressed air before reinstalling it on the pump drive.

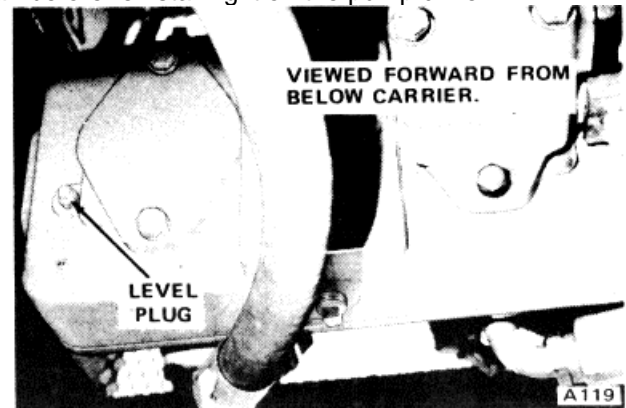

Figure 4-15. Pump Drive Level Plug

**CHECK CLUTCH OIL LEVEL**

To check the oil level in the clutch master cylinder, proceed as follows (see Figure 4-16): 1. Remove the panel on the front side of the carrier cab dashboard.

2. Clean the area around the master cylinder filler cap, and then remove the filler cap. The oil should be up to the bottom of the filler neck. If necessary, add oil of the type specified in Section III to bring the oil to the proper level. Replace the filler cap.

**NOTE**

If the oil in the master cylinder is extremely low, check the master cylinder, slave cylinder, and connecting lines and fittings for leaks. Repair or replace any faulty components immediately.

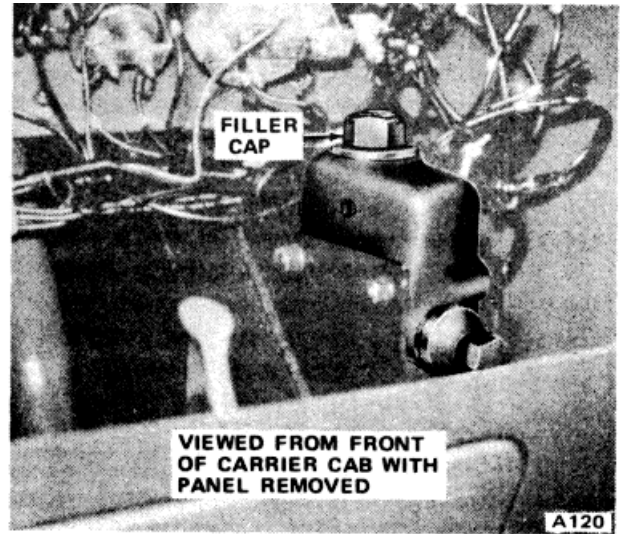

Figure 4-16. Clutch Master Cylinder

**'D' Maintenance Checks**

Repeat the "A, B, & C" Maintenance Checks each time the following checks are performed.

**PERFORM QUARTERLY LUBRICATION**

Refer to the lubrication charts, in Section III, and lubricate the quarterly lubrication points with the type of lubricant specified.

**DRAIN SEDIMENT & WATER FROM FUEL TANK**

Keep the fuel tank filled to reduce condensation to a minimum. Since some condensation and sediment will accumulate in the fuel tank, the drain at the bottom of the fuel tank should be opened every 500 hours to drain off any accumulated water and sediment.

**CHECK CONDITION OF COOLING SYSTEM HOSES**

Inspect all of the engine cooling system hoses at least once every 500 hours for signs of deterioration. Replace the hoses if necessary.

**CHECK AIR VALVES & CYLINDERS FOR LEAKS**

All air valves and cylinders should be checked periodically for leaks. To do so, actuate the valve or cylinder and coat the device with a soap solution. Leakage which causes a bubble one inch or larger to form in one second is considered excessive, and the device should be scheduled for repair or replacement.

**CLEAN STEERING/OUTRIGGER FILTER**

The power steering/outrigger filter is located on the left side of the engine compartment, ahead of the radiator. Access to the filter is gained by reaching up from below the front of the machine

To clean the steering/outrigger filter, proceed as follows: (see Figure 4-17):

1. Block the machine to prevent possible machine movement.
2. Remove the filter bowl, using a suitable box wrench.
3. Remove the wire filter element from the bowl and inspect the material trapped in the filter. The type of material trapped in the filter can indicate that a component in the system is deteriorating or is about to fail.
4. Clean the filter element in a suitable solvent and dry it with clean compressed air. Assemble the filter element on the filter head, and then replace the filter bowl. Tighten the filter bowl using a suitable box wrench.

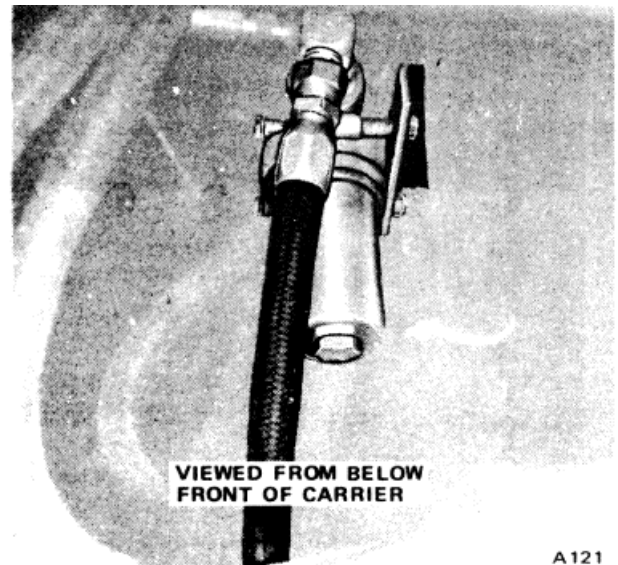

Figure 4-17. Steering/Outrigger Filter

**CHECK CLUTCH ADJUSTMENT**

The amount of clutch pedal free travel should be checked to determine the need for clutch adjustment. Free travel is the distance the pedal can be depressed before resistance is felt, and is best checked by hand.

The proper amount of clutch pedal free travel is 3/4 to 1 inch (1.9-2.54 cm).

A gradual reduction in the amount of free travel is a normal condition, caused by wearing of the clutch friction material. If free travel is less than 3/4 inch (1.9 mm), adjust the clutch as follows (see Figure 4-18):

1. Loosen the jam nut. Back the adjusting screw out until the clearance between the release levers is approximately 1/16 inch (0.16 mm).

2. Check clutch pedal free travel. If the free travel is within 3/4 to 1 inch (1.9-2.54 cm), hold the adjusting screw and tighten the jam nut.

3. If the free travel is not within 3/4 to 1 inch (1.9-2.54 cm), increase or decrease the clearance between the release levers until proper free travel is obtained. Then hold the adjusting screw and tighten the jam nut.

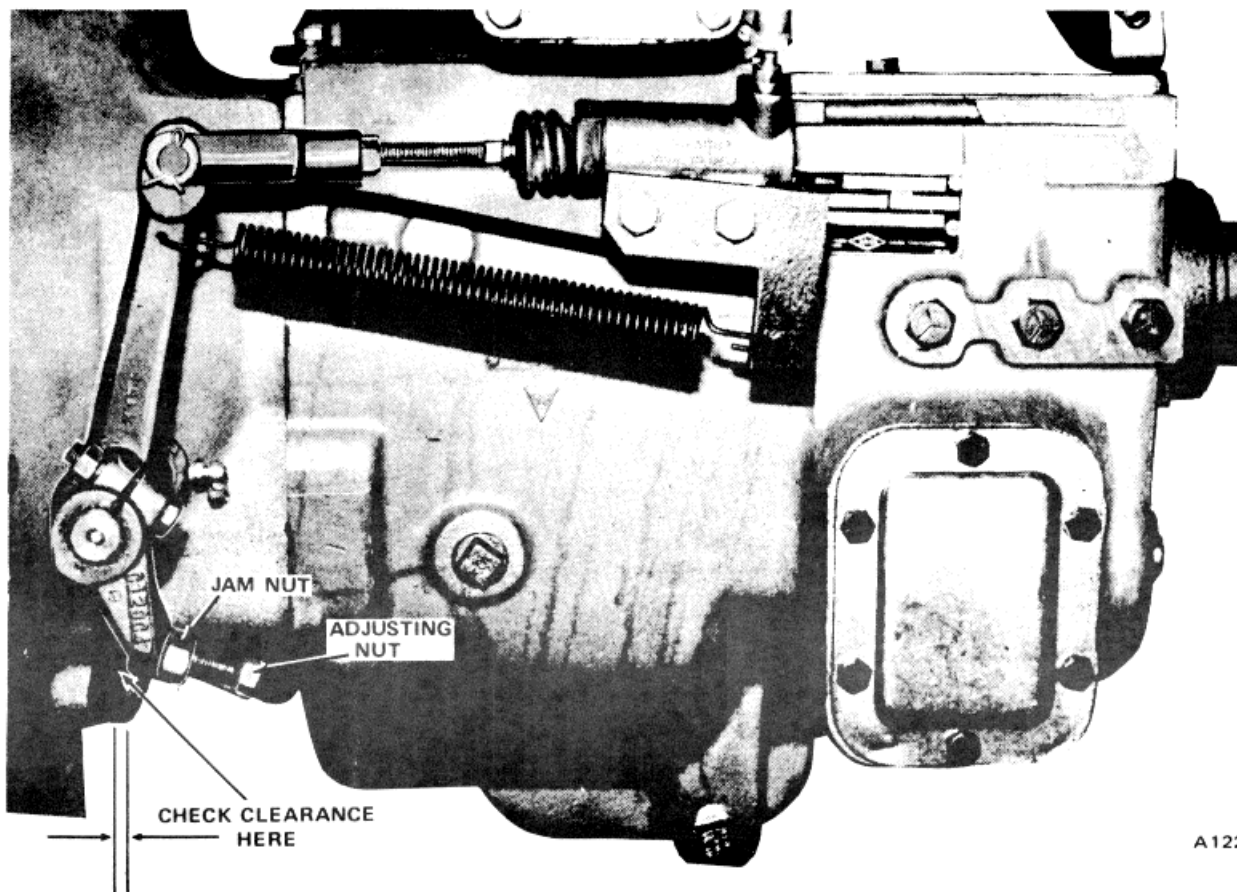

A122

Figure 4-18. Clutch Adjustment



**'E' Maintenance Checks**

Perform "A, B, C, & D" Maintenance Checks each time the following check is performed.

**CLEAN CRANKCASE BREATHER**

Remove the crankcase breather from the engine every 1000 hours and wash the steel mesh pad in fuel oil and dry it with compressed air. This cleaning period may be reduced or lengthened according to the severity of service.

**CLEAN AND INSPECT BLOWER SCREEN**

Inspect the blower screen and gasket assembly, between the blower and air inlet housing, every 1,000 hours and, if necessary, clean the screen in fuel oil. Dry the screen with compressed air. Reinstall the screen and gasket assembly with the screen side of the assembly toward the blower.

**CLEAN COOLING SYSTEM**

Clean the cooling system using a good radiator cleaning compound in accordance with the instruction on the container. After the cleaning operation, rinse the cooling system thoroughly with fresh water; then fill the system with soft water, adding a good grade of rust inhibitor or high boiling point type antifreeze as specified in the Engine Manufacturer's Manual. With the use of a proper antifreeze or rust inhibitor, this interval may be lengthened until, normally, this cleaning is done only in the spring or fall. The length of this interval will, however, depend upon an inspection for rust or other deposits on the internal walls of the cooling system. When a thorough cleaning of the cooling system is required, it should be reverse flushed.

**CLEAN EXTERIOR OF RADIATOR**

Inspect the exterior of the radiator core and, if necessary, clean it with a quality degreasing solvent and dry it with compressed air. It may be necessary to clean the radiator more frequently if the machine is being operated in extremely dusty or dirty areas.

**CLEAN HYDRAULIC TANK BREATHER**

Remove the hydraulic tank breather and wash it in fuel oil. Dry the breather with compressed air. This cleaning period may be reduced or lengthened according to the severity of service.

**CHANGE AXLE OIL**

The oil in the rear axles should be changed twice yearly (spring and fall). Each time the oil is changed, the magnetic drain plug must be cleaned, to remove any accumulated material, before it is replaced.

**NOTE**

**The axle manufacturer recommends a drain plug with a magnetic element capable of picking up approximately 2 pounds of low carbon steel.**

To change the axle oil, proceed as follows (see Figure 4-19): 1. Drive the machine to warm the oil in the axles to normal operating temperature.

2. Remove the drain plug and drain the oil into a suitable container. Clean the drain plug.

3. Install the drain plug and add oil of the type specified in Section III, until the oil reaches the bottom of the oil level plug opening. Replace the filler-level plug.

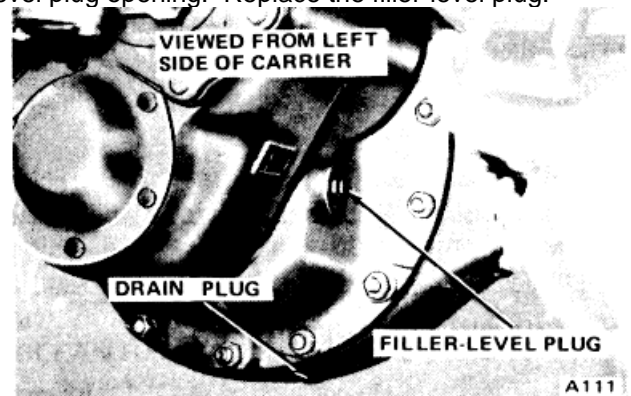

Figure 4-19. Changing Rear Axle Oil

**CHANGE MAIN TRANSMISSION OIL**

To change the oil in the main transmission, proceed as follows (see Figure 4-20).

1. Drive the machine to warm the oil in the transmission to normal operating temperature.
2. Remove the drain plug and drain the oil into a suitable container. Clean the drain plug.
3. Install the drain plug and remove the filler-level plug. Add oil through the filler-level plug opening until the oil reaches the bottom of the opening. Replace the filler-level plug.

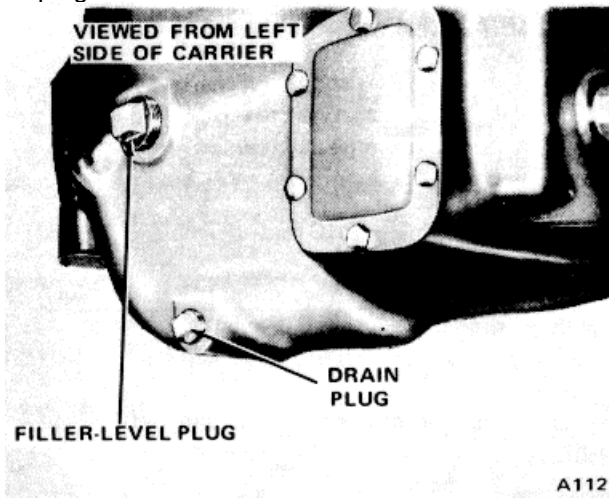

Figure 4-20. Changing Main Transmission Oil

**CHANGE AUXILIARY TRANSMISSION OIL**

To change the oil in the auxiliary transmission, proceed as follows (see Figure 4-21): 1. Drive the machine to warm the oil in the transmission to normal operating temperature.

2. Remove the drain plug and drain the oil into a suitable container. Clean the drain plug.
3. Install the drain plug and remove the filler-level plug.

Add oil through the filler-level plug opening until the oil reaches the bottom of the opening. Replace the filler-level plug.

**CHANGE PUMP DRIVE OIL**

To change the oil in the pump drive, proceed as follows (see Figure 4-22):

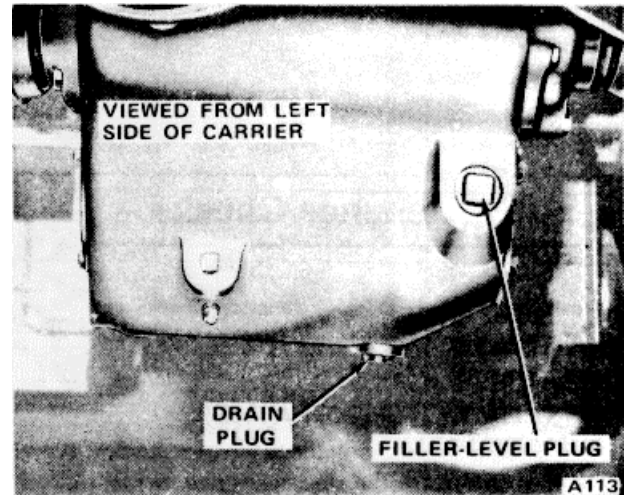

Figure 4-21. Changing Auxiliary Transmission Oil

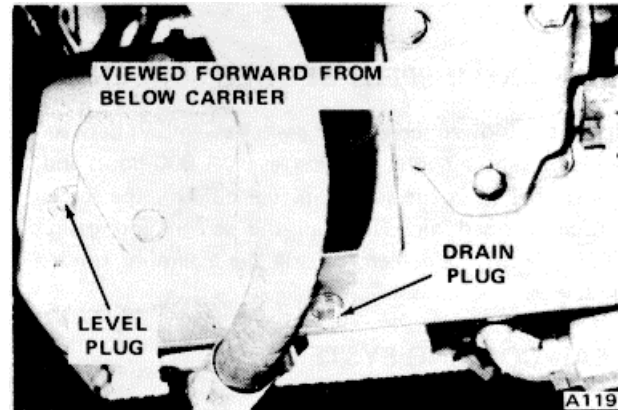

Figure 4-22. Changing Pump Drive Oil

1. Engage the pump drive and run it until the oil is warmed to normal operating temperature.
2. Remove the drain plug and drain the oil into a suitable container. Clean the drain plug. Replace the drain plug after all the oil has been drained from the pump drive.
3. Remove the breather at the top of the pump drive, wash it in fuel oil, and dry it with compressed air.
4. Clean the area around the oil level plug opening, and then remove the oil level plug. Add oil through the breather opening until the oil reaches the bottom of the oil level opening. Replace the breather and oil level plug.

**SERVICE QUICK START**

Periodically, service the quick start system, if the machine is so equipped, to assure good performance (see Figure 4-23):

## SECTION IV

## PREVENTIVE MAINTENANCE

1. Remove the fluid cylinder and lubricate the valve around the push rod under the gasket with a few drops of oil.
2. Lubricate the actuator cable.
3. Actuate the valve with the cable to distribute the oil on the cable and allow the oil to run down through the valve.
4. Remove any dirt from the orifice by removing the air inlet housing fitting, the orifice block and the screen. Then, blow air through the orifice end only. These items are located beneath the fluid cylinder.
5. Assemble and tighten the air inlet housing fitting to the actuator valve and tube.

6. Check for leakage of fluid (fogging) on the outside of the engine air inlet housing by actuating the starting aid while the engine is stopped. If fogging occurs, disassemble and retighten the air inlet housing fitting to the housing.

### **CAUTION**

**Do not actuate the starting aid more than once with the engine stopped. Over-loading the engine air box with this volatile fluid could result in a minor explosion.**

7. Replace the fluid cylinder. Hand tighten the cylinder.

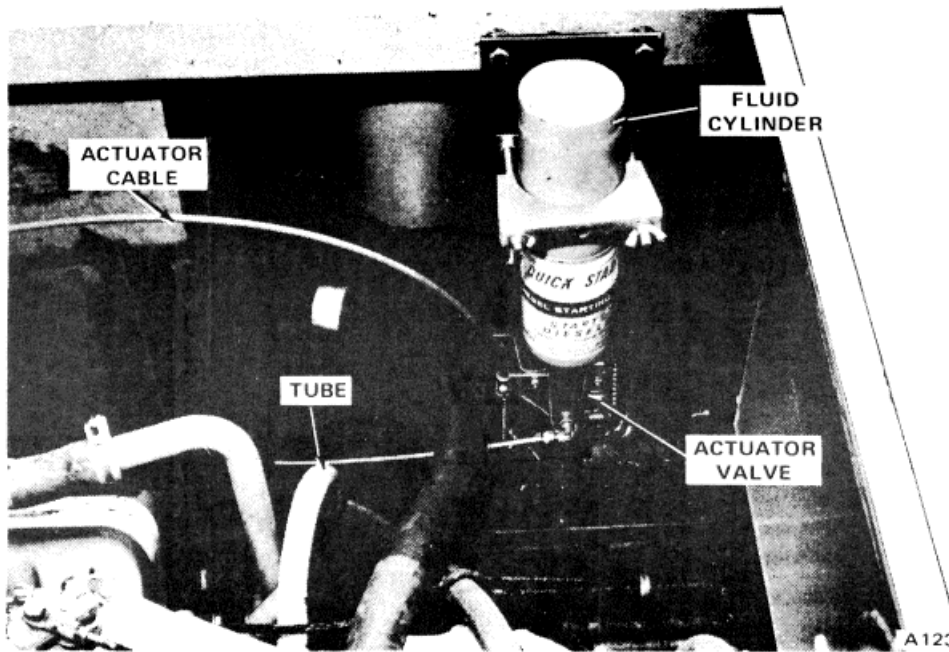

Figure 4-23. Quick Start

## SECTION V MACHINE STORAGE

### GENERAL

If this machine is to be removed from service for an extended period of time, the following procedure should be used when removing the machine from service and placing the machine back into service to ensure proper operation of the machine at all times.

### PREPARATION FOR SHORT TERM STORAGE GENERAL.

Short term storage for the machine proper and for Detroit Diesel engine is 30 days or less. For the Cummins engines, short term storage is for periods of up to six months. To prepare for longer storage periods, refer to the topic, "Preparation for Long Term Storage".

Separate procedures are outlined below for the machine proper and for both engine types.

**MACHINE PREPARATION.** Perform the following to prepare the machine proper for short term storage (30 days or less):

1. Clean the entire machine.

2. Touch up painted surfaces as necessary, after proper preparation and priming.

3. Lubricate the machine in accordance with the instruction on the lubrication charts.

#### NOTE

**Step 4 is unnecessary if the machine is stored in a building and the air will be dry for the duration of storage..**

4. With the boom retracted and lowered to the boom rest, coat the exposed portions of the hoist cylinder piston rods with multipurpose grease.

### DETROIT DIESEL ENGINE PREPARATION.

Prepare the Detroit Diesel engine for short term storage (30 days or less) by performing the following steps.

1. With the engine warmed to normal operating temperature, drain the crankcase.

2. Replace the drain plug, change the oil filter element and fill the crankcase to the proper level with the recommended oil type.

3. Fill the fuel tank and operate the engine for two minutes at 1200 RPM and no load.

#### NOTE

**Do not drain the crankcase or fuel tank after this run.**

4. Service the engine air cleaner, if inspection reveals the need.

5. Check the condition of the water, or antifreeze solution, in the engine cooling system. If the coolant appears unfit for further use, drain the cooling system, flush with clean soft water, and refill with clean water or a permanent antifreeze solution according to expected weather conditions. Add a high quality rust inhibitor if only water is used in the system, and run the engine until the rust inhibitor is thoroughly mixed.

6. Clean the exterior of the engine, except the electrical components and wiring, with diesel fuel and dry with air.

7. Seal the engine exhaust outlet and air cleaner face using a suitable water resistant material: The material used must be waterproof, vapor-proof and be strong enough to resist puncture and damage from the expansion of entrapped air.

**CUMMINS ENGINE PREPARATION.** The following steps will prepare a Cummins engine for storage for up to six months.

1. Start the engine and gradually increase speed up to 1200 RPM. Run the engine at 1200 RPM until it is thoroughly warmed.

2. Disconnect both the fuel supply line and the injector drain line at the carrier fuel tank. Mark these lines for positive identification.

## SECTION V

## MACHINE STORAGE

3. Fill one portable container with regular diesel fuel and a second container with preservative oil (Daubert Chemical Co., Nox-Rust No. 518, or equal Daubert Chemical Co., 2000 Spring Rd., Oakville, Il.).
4. Insert both the fuel supply line and the injector drain line into the container of diesel fuel and start the engine.
5. When the engine is running smoothly at idle, switch the fuel supply line over to the container of preservative oil. Operate the engine for five to ten minutes on the preservative oil.
6. Stop the engine and reconnect the fuel lines to the fuel tank.
7. Drain the engine crankcase, fuel filters and the carrier fuel tank. Reinstall the drain plugs.
8. New oil may be added to the crankcase, or the crankcase may remain empty for the duration of storage. If it is left empty, appropriate tags should be placed on the engine and in the carrier cab.
9. Remove the air line connecting the engine air cleaner to the intake manifolds.
10. Turn the fuel pump manual shut-off valve to "off" so the engine will not start.
11. While cranking the engine slowly and intermittently, spray approximately one-half cup of SAE-10 motor oil into the engine intake manifold and the air compressor. Either a hand or power sprayer may be used.
12. Cover all intake manifold openings with tape to prevent the entrance of dirt and moisture. Cover all other engine openings, including coolant inlets, cylinder block, oil breather and crankcase in a similar manner.
13. Drain the engine cooling system, unless it is filled with a permanent antifreeze solution with a rust inhibitor added.
14. If possible, store the machine in a building, where the air is dry and the temperature uniform.
15. Every three to four weeks of storage, crank the engine over two or three turns.

### PREPARATION FOR LONG TERM STORAGE

GENERAL. Long term storage for the machine proper and for the Detroit Diesel engines is for periods longer than 30 days. Long term storage for a Cummins engine is for periods longer than six months. Separate procedures are outlined below for preparation of the machine

proper, the Detroit Diesel engine and the Cummins engine.

MACHINE PREPARATION. To prepare the machine proper for long term storage (periods in excess of 30 days), proceed as follows:

1. Clean the entire machine thoroughly.
2. Inspect for loose or missing attaching hardware throughout the machine. Tighten or replace as necessary.
3. Inspect all painted surfaces for rust, bare metal, chipping, or other defects. Prepare, prime and repaint as necessary.
4. Liberally lubricate all points equipped with grease fittings.
5. Drain the swing reducer gear case, the pump drive housing and the winch planetary housing in the upper. On the carrier, drain the main and auxiliary transmissions, the rear axle differentials, the interaxle differential lockout housing and the steering gear housing. Clean the magnetic plugs and breathers, replace the drain plugs, and refill each housing and case with the oil type specified on the lubrication charts.
6. Spray or brush a liberal coat of open gear lubricant on the slewing ring gear.
7. Remove the battery, clean it thoroughly and store it in a cool, dry location, where the temperature will not fall below 320F. (0°C.). Check the battery charge periodically during storage and recharge as necessary.
8. Clean the battery compartment, using a soda and water solution if necessary to remove corrosion. Wrap the cable terminals with waterproof tape, after cleaning.
9. Run the engine until the hydraulic oil is warm. Then drain the hydraulic system completely.
10. Replace the hydraulic filter cartridges and gaskets.
11. Refill the reservoir to the prescribed level with the proper oil type.
12. Operate all hydraulic functions to distribute the new oil throughout the systems.
13. Apply a suitable preservative grease to exposed portions of hydraulic cylinder piston rods, control valve spools, and other exposed unpainted surfaces.
14. When the machine is parked in the spot it is to be stored in, fill the hydraulic reservoir to the top with hydraulic oil.

DETROIT DIESEL ENGINE PREPARATION. To prepare the Detroit Diesel engines for long term storage

## SECTION V

## MACHINE STORAGE

(periods in excess of 30 days), proceed as follows:

- 1 Drain the cooling system and flush thoroughly with clean, soft water.
2. Refill the cooling system with clean, soft water and a high quality corrosion inhibitor.
3. Circulate the coolant by running the engine until normal operating temperature is reached. Shut off the engine.
4. Drain the engine oil, while the engine is still hot.
5. Install and tighten the engine oil drain plug, replace the engine oil filter and filter gasket, and refill the engine crankcase to the normal level with a 30 weight preservative oil.
6. Remove and inspect the fuel injectors. Have them reconditioned, if necessary.
7. Drain the fuel tank, completely, and pour a small quantity of rust preventing fuel oil (American Oil Co. No. LF4089, Mobil No. 4Y17, or equal) into the tank. Enough rust preventive fuel to run the engines for about 10 minutes is all that is needed.
8. Remove and discard the fuel filter elements from the engine. Wash the shells in clean diesel fuel and insert new elements. Fill the cavity between the elements and shells about two-thirds full of the same rust preventive fuel that was added to the tank. Reinstall the fuel filters and tighten the retaining bolts securely.
9. Start the engine and let it run for about five minutes to circulate the rust preventive through the fuel system.
10. Service the air cleaner, install a new cartridge if inspection reveals the need. Cover the face of the air cleaner with heavy plastic, taped to form an airtight seal.
11. Drain the engine cooling system. Tighten the drain cocks and radiator cap securely.
12. The preservative oil may be drained from the engine, if desired, and saved for reuse, or it can be left in or the duration of the storage. If the oil is drained, install and tighten the drain plug.
13. Cover the exhaust outlet with moisture resistant tape, or other suitable material.
14. Loosen the drive belts on the engine and insert heavy paper strips between the pulleys and belts. This will prevent sticking. Leave the belts loose.
15. Clean the exterior painted surfaces of the engine and dry thoroughly. Spray the surfaces with a suitable liquid automotive wax, a synthetic resin varnish or a rust preventive compound.

16. Cover the engine with a weather-resistant tarpaulin or other cover, if the machine is stored outdoors. Cover with a heavy plastic sheet if the machine is stored indoors.

**CUMMINS ENGINE PREPARATION.** To prepare a Cummins engine for long term storage (periods in excess of six months), proceed as follows: 1. Perform step (1) of the temporary storage procedure for Cummins engines.

2. Drain the oil from the engine crankcase and refill to the proper level with an SAE-30 preservative oil (Shell Brand Code 66202, Texaco Preservative Oil 30; or equal).
3. Perform steps (2) through (6) of the temporary storage procedure for Cummins engines.
4. Drain the carrier fuel tank, replace the drain plug, and cover the filler cap vent with waterproof tape.
5. Drain the engine crankcase, air compressor oil sump and fuel filters. Replace the drain plugs and tighten securely.

### **CAUTION**

**In step (6), below, inject approximately one quarter cup of preservative oil into each port. A larger amount may cause hydraulic lock upon startup, unless the excess oil is purged from the combustion chambers.**

6. Remove the intake and exhaust manifolds and spray all intake and exhaust ports, including the air compressor intake port, with preservative oil of the type added to the crankcase.
7. Replace the intake and exhaust manifolds.
8. Drain the engine cooling system and refill with clean soft water and a high quality rust preventive compound. Flush the cooling system thoroughly and drain while it is hot.

### **NOTE**

**Water soluble oils are available for flushing the cooling system in step (8). If these are used, the entire cooling system must be flushed before restoring the engine to service.**

9. Loosen the tension on all drive belts.
10. Brush or spray a film of rust preventive compound on all exposed, unpainted surfaces of the engine. Use 1-5-3

## SECTION V

## MACHINE STORAGE

Daubert Chemical Co. Nox-Rust 207, E.F. Houghton Co. Cosmoline 1046, Pennsylvania Refining Co. Petrotect 3; or equal.

11. Remove the cylinder head covers and spray preservative oil, of the type added to the crankcase, over the rocker arms, valve stems, springs, guides, crossheads and push rods. Replace the covers.

12. Cover all engine openings, including manifold exhaust and intake ports, coolant inlets to cylinder head and block, oil breather and crankcase, with heavy paper and tape.

13. Tag the engine to indicate that it has been treated with preservative oil and that the cooling system has been drained. This tag should warn against turning the engine over until it is restored to service. The tag should also show the date on which preservation was accomplished, and that the engine is not to be run without first removing the preservative film.

14. If possible, store the machine in a building where the air is dry and the temperature will remain uniform.

15. Inspect the engine periodically during storage for rust or corrosion and take corrective steps as necessary.

### **NOTE**

**If the machine is stored for longer than 24 months, repeat the above preservation procedure. This will insure continued preservation of the Cummins engine.**

### **REMOVAL FROM SHORT TERM STORAGE GENERAL.**

The procedures outlined below must be carefully followed to insure that the machine is properly restored to normal service following short term storage. Note that separate procedures are given for the Detroit Diesel engine, the Cummins engine and the machine proper.

**RESTORING DETROIT DIESEL ENGINES TO SERVICE.** To restore the Detroit Diesel engine to service following short term storage, proceed as follows.

1. Remove the seals from the engine openings.
2. Check the oil level in the engine crankcase. Add oil as necessary, per the lubrication charts.
3. Check the coolant level in the radiator. Add clean water or antifreeze, as applicable, if the level is low.

4. Make a thorough visual inspection of the machine to insure that the engine can be safely started and then start the engine in the normal manner. Observe for any unusual noise, or other symptoms of malfunction. Shut the engine down immediately if there is any evidence of malfunction.

**RESTORING CUMMINS ENGINES TO SERVICE.** To restore the Cummins engine to service following short term storage, proceed as follows.

1. Clean all accumulated dirt from the engine exterior.
2. Remove all paper covers, tape and wrappings.
3. Using a suitable solvent, cleaner or degreaser, remove rust preventive compound from the unpainted surfaces of the engine.
4. Refill the engine crankcase with new oil of the type specified in the carrier lubrication chart.
5. Flush the cooling system and refill with either clean water and a corrosion inhibitor or an antifreeze solution, as applicable.
6. Have the fuel injectors, valves and drive belts adjusted. Also, check head capscrews, oil filter connections, air cleaner, screens and traps.
7. Remove the plug from the gear case cover to prime the lubricating system. Then connect a hand or motordriven priming pump from a source of clean lubricating oil to the plug boss in the gear case cover.

8. Operate the priming pump until a minimum pressure of 30 psi (2 bars) is obtained. Crank the engine at least 15 seconds (with the fuel shut-off valve closed or disconnected to prevent starting), while maintaining the external oil pressure at a minimum of 15 psi (1 bar).

9. Remove the priming pump line and replace the plug in the gear case cover. Torque the plug to 15 to 20 ft-lbs (2-2.7 m-kg). Fill the crankcase to the "H" (high) mark on the dipstick.

10. Run the engine for a short time. Then, clean the fuel pump strainer and replace the fuel filter and oil filter cartridges.

**RESTORING MACHINE PROPER TO SERVICE.** To restore the machine proper to service following short term storage, proceed as follows:

1. Lubricate all points equipped with grease fittings, per the lubrication charts.
2. Remove preservative grease, if applicable, from the cylinder piston rods and other surfaces where applied.

## SECTION V

## MACHINE STORAGE

3. Check the oil levels in each gear housing in the upper and the lower, and the levels in the main and auxiliary transmissions. Add oil as necessary as specified in the lubrication charts.
4. Check the oil level in the hydraulic reservoir. Add oil of the proper types, as required.
5. Install the battery, fully charged, and connect it.
6. Make a thorough visual inspection of the entire machine before operating it for the first time following storage. Check, especially, for damaged or deteriorated hydraulic hoses.

### REMOVAL FROM LONG TERM STORAGE GENERAL.

The procedures outlined in the following paragraphs must be carefully followed to insure that the machine is properly restored to normal service. Separate procedures are provided for the Detroit Diesel engine, the Cummins engine and the machine proper.

### RESTORING DETROIT DIESEL ENGINES TO SERVICE.

To restore the Detroit Diesel engine to service following long term storage, proceed as follows:

1. Drain the preservative oil from the engine, if applicable, and refill the crankcase with the oil type recommended for normal operation. Allow for the oil added in Step 2, below.
2. Remove the valve rocker covers from the engine and pour at least one-half gallon (1.9 l) of engine oil over the rocker arms and push rods. Replace the covers.
3. Check the condition of the radiator hoses and clamps. Then, fill the engine cooling system with dean, soft water and a high quality rust inhibitor or a solution of permanent antifreeze, depending on expected weather conditions.
4. Remove the seals from the engine exhaust outlets and air cleaner.
5. Fill the fuel tank.
6. Install the battery, fully charged, in the carrier.
7. Using diesel fuel, remove the rust preventive from the engine exterior.
8. Remove the paper from between the drive belts and pulleys and tighten the belts. Refer to the engine manufacturer's manuals.
9. Make a final inspection of the carrier and the upper to insure that the engine can be safely started.

10. Start the engine in the normal manner and allow it to warm up fully. The preservative fuel will produce a harmless smoky exhaust until it is consumed.

11. Observe for unusual noise or other symptoms of malfunction when the engine is started. Shut the engine down immediately if there is any evidence of malfunction.

### RESTORING CUMMINS ENGINES TO SERVICE.

To restore the Cummins engine to service following long term storage, proceed as follows:

1. Clean all accumulated dirt from the engine exterior.
2. Remove all paper covers, tape and wrappings.
3. Using a suitable solvent, cleaner or degreaser, remove rust preventive compound from the unpainted surfaces of the engine.
4. Flush the entire fuel system with clean fuel oil until all preservative oil is removed from the system.
5. Remove the plug from the oil header and force hot, light mineral oil through the oil passages to flush away all preservative oil and gummed oil that may have accumulated. Bar the engine over several times during this flushing operation.
6. Remove all filter screens and strainers and clean them thoroughly. Refer to the engine manufacturer's manual for locations and procedures.
7. Fill the engine crankcase with new oil of the type and amount specified in the carrier lubrication chart. Install a new oil filter cartridge.
8. Flush the cooling system thoroughly and refill with clean, soft water and a high quality corrosion inhibitor or a permanent antifreeze solution, as applicable.
9. Install the carrier battery, fully charged, and connect it.
10. Clean the fuel pump strainer and install a new fuel filter cartridge. Then fill the carrier fuel tank with the proper grade of diesel fuel.
11. Prime the engine lubrication system as instructed in 7 through 9 of "Removal From Short Term Storage".
12. Make a thorough visual inspection of the carrier to insure that the engine can be started safely and the carrier driven. Correct any malfunction found.



## SECTION V

## MACHINE STORAGE

13. The engine can now be started in the normal manner.

**RESTORING MACHINE PROPER TO SERVICE.** To restore the machine proper to service following long term storage, proceed as follows:

1. Clean the entire machine thoroughly. then inspect the machine thoroughly, paying particular attention to hydraulic hoses, tubes and fittings.
2. Lubricate all points equipped with grease fittings, per the lubrication charts.

3. Check the oil levels in the upper gear housings and in the carrier drive train components. Add oil as required of the types specified in the lubrication charts.

4. Drain the hydraulic reservoir down to the proper level.
5. Remove the preservative grease from the cylinder rod pistons and other machined surfaces, if applicable.
6. Check all tire pressures, and the general condition of the tires.

**PART TWO**

**WEIGHLOAD AUTOMATIC SAFE LOAD INDICATOR**

# WEIGHLOAD AUTOMATIC SAFE LOAD INDICATOR MK. I

## MODELS 4, 5 & 6

### OPERATOR'S INSTRUCTIONS

#### GENERAL DESCRIPTION.

The basic equipment consists of three main Items:-

- (a) Control Box.
- (b) Dynamometer.
- (c) Bell Unit.

Occasionally the following is supplied in addition:-

- (d) Summator Unit, for use when a second Dynamometer is installed, e.g. on a separate Whip Hoist Rope.
- (e) Remote Radius Indicator.

The Dynamometer is mounted in such a position that the hoist rope passes through it. According to the type of crane, it may be rigidly mounted on the base section of the boom or on a 'swinging arm' frame which allows it to follow the true path of the rope.

As the load on the hoist rope increases, the rope within the Dynamometer tends to straighten out, exerting an increasing force on the center sheave which, in turn, applies an increasing force on the Hydrostatic Load Cell mounted beneath it. The force on the Load Cell is converted to fluid pressure and transmitted through an armoured, flexible capillary tube to the Control Box which is mounted at a convenient position within the vision of the crane operator.

The Control Box contains a dial with an adjustable range. The pressure from the Load Cell causes a black pointer to rotate around this dial indicating, at all times,, the actual load being lifted or suspended.

A second pointer, colored red-, indicates the Safe Working Load for the actual radius at which the crane is working. This red pointer is driven by a cam in the Control Box operated by a flexible drive from the boom hinge pin. The gear train which drives the red pointer also rotates electrical contacts which light a warning light at 90% S.W.L. and sounds a warning bell should the Safe Working Load be exceeded.

The Bell and Light Unit is a separate item, mounted in the crane cab so that it is clearly audible to the Operator-

**VISUAL INDICATION.** The safety margin is clearly indicated by the gap between the black pointer, indicating the load on the crane hook, and the red pointer, indicating the Safe Working Load. An amber light is illuminated at 90% S.W.L. A Red Light goes on at 100% S.W.L.

**AUDIBLE WARNING.** The Warning Bell sounds when the lifted load meets or exceeds the Safe Working Load.

It follows, therefore, that as soon as the black pointer reaches the red pointer the load should be reduced or the boom derricked in. On no account should the crane be operated with the bell continuously ringing.

In addition to the dial indicating the load on the crane hook, the Control Box is fitted with a further scale indicating the actual working radius of the crane. This is positioned in the lower half of the Control Box.

### **ADJUSTMENTS.**

Certain adjustments are necessary to cater for the various duties of the crane and these have been made as simple as possible, In most cases, three adjustments only are necessary and are as follows:-

1. Cam Change.
2. Reeving Change
3. Black Pointer Zero.

Describing these adjustments in detail:-

1. **CAM CHANGE.** The cam is a brown fibre plate which is mounted within the Control Box, secured by one wing nut on its boss. Access to this cam is obtained by opening the front door of the Control Box. All the

information required to identify the cam is stamped on the face, namely:-

- (a) Crane on outriggers, side and rear ratings condition.
- (b) Length of boom or jib.
- (c) Number of parts of line.

Additional duties may also be catered for, e.g., "Main boom with jib attached" etc., etc., and it is most important to ensure that the correct cam is fitted to suit the working condition of the crane.

When fitting a cam, locate it over its mounting spindle and location dowel, turning the cam and geared boss so that the cam slot lines up with the follower peg protruding from the top bracket of the cross slide. When the cam is correctly located, fully tighten the wing nut.

On the radius indicator, the scale is also stamped with identifying information and must be changed when different boom lengths are employed and/or jibs. To change a radius scale, lift it out of its retaining guides and replace it with the appropriate scale.

2. REEVING CHANGE. In most cases, the only adjustment necessary, apart from ensuring that the correct cam is fitted to suit the number of parts, is to change the scale of the weighing dial in the Control Box so that the correct number of parts appears in the window on the left hand side of the dial. This is achieved by rotating the knurled knob at the top left hand side of the Control Box.
3. BLACK POINTER ZERO. This adjustment is made at the Control Box and may be necessary at certain times. The adjuster is on the top right hand side of the control box and is a recessed screwdriver slot. **DO NOT ATTEMPT TO TURN THIS ADJUSTMENT PAST IT'S INTERIOR STOPS , i.e. WHEN RESISTANCE IS FELT.**

Counter-clockwise rotation of the adjuster will cause the black pointer to rise and vice-versa. Once the pointer is correctly set, slightly rotate the adjuster in the opposite direction to relieve the strain on it. The Indicator should be lightly tapped during this adjustment.

As the block is normally part of the lifted load, the black pointer reading should equal the weight of the block, when the block is hanging free and unloaded, and NOT zero.

The electrical circuit can be tested by depressing the switch on the top of the Control Box causing the relay to operate and sounding the warning bell. THIS SHOULD BE TESTED AT LEAST ONCE EVERY WORKING DAY. If a separate isolation switch is fitted, ensure that it is switched on.

The foregoing information can be condensed into the following main points to be observed when operating the crane:-

**AT ALL TIMES, ENSURE THAT-**

1. Correct cam is fitted to suit boom length and number of parts.
2. Correct radius scale is fitted.
3. Index window on dial of Control Box shows correct number of parts and no further adjustment is necessary at the Dynamometer.
4. Load Cell is correctly positioned in Dynamometer.
5. Dynamometer is free of accumulated rope grease.
6. Bowden cables from the boom hinge pin are lubricated and free of ice.
7. Alarm operates when test button is pressed.

NOTE:--RED POINTER INDICATES SAFE WORKING LOAD. BLACK POINTER INDICATES LOAD BEING LIFTED WHEN BOTH POINTERS COINCIDE, OVERLOAD IS IMMINENT. WHEN BELL RINGS STEADILY, IMMEDIATELY LOWER LOAD OR REDUCE RADIUS.

**IMPORTANT.** During constant clamshell or Piling operations, REMOVE DYNAMOMETER.

Should any query arise with this equipment, the Serial Number of the Unit should be quoted in all communications. The Serial Number has the prefix "CO....." and appears on the nameplates of the Control Box and the Dynamometer.

Maintenance Instructions appear at the end of these instructions and should be carried out at regular intervals.

**Change 1 2-1-4**

## **MODELS 4T & 5T**

The following additional equipment is supplied for use on TELESCOPIC Cranes:-

(f) Spring operated Recoil Drum assembly.

(g) Rotary Flexible Drive.

The Recoil Drum assembly is used to transmit the telescoping movement of the boom to the Control Box. A wire cable, attached at one end to the boom head, is passed down the boom through suitable guides and is wrapped round the drum which is spring loaded to keep the cable taut. Rotation of the drum, during telescoping, is geared through a chain drive and gear box to the Rotary Flexible Drive which connects with the Control Box. Within the Control Box, a lead screw is built in to the actuating arm (miniature boom) and is driven by the Rotary Flexible Drive, accurately positioning the slide block in proportion to the boom length. The actuating arm is marked with a scale indicating the length of boom extended.

### **ADJUSTMENTS.**

There are no further adjustments to make on Units on Telescopic Cranes. In this case, all the instructions given in the previous pages apply, especially those with reference to the use of the correct cam to suit the working condition of the crane. In most cases, when working with the main boom, it is only necessary to change the cam if the number of parts are changed. Use of the manual section and jib also requires the cam to be changed.

The Radius Scale, showing the working radius of the crane, is standard on all Units supplied for Telescopic Cranes and must be changed when working with Manual Extension and/or Jibs.

NOTE:- When using the jib or manual extension, the ratings are proportional to angle. Consequently, the wire from the recoil drum must be fastened to the place provided on the base section.

**MAINTENANCE.** Models 4, 5 & 6.

Dynamometer. Clean out any clogged grease and dirt, especially adjacent to the center roller, "U"-shaped block and Load cell.

Check the mounting bolts and nuts for tightness and also all other bolts and nuts on the Dynamometer and supporting framework. This check should be carried out at short, regular intervals.

During the normal crane overhaul, the rollers should be removed from the Dynamometer, the bearings washed in solvent and repacked with Shell Alvania No. 2 grease.

Should it be necessary to remove the Load Cell from the Dynamometer, it is only necessary to remove the two 5/16" Allen screws from the underside of the platform on which the Load Cell is mounted. The Load Cell is located on a shallow pin and must be slightly lifted before being drawn out of the Dynamometer. THE HOIST ROPE MUST BE COMPLETELY UNLOADED WITH THE BLOCK RESTING ON THE GROUND, while the Load Cell is out of the Dynamometer. The "U"-shaped block may be lifted by hand to give added clearance when removing the cell.

LOAD CELL ASSEMBLY. The Load' Cell, flexible capillary and Load Indicator assembly is a sealed unit and capillary joints must NOT be dismantled under any circumstances. The only maintenance necessary is to regularly clean away any clogged grease or dirt from the cell and to ensure that it is correctly located and secured in the Dynamometer.

Should the black pointer in the Control Box fail to operate when the crane hook is loaded and the Load Cell is suspect, the cell may be removed from the Dynamometer (see Maintenance Dynamometer') and loaded by squeezing in a vice. If there is still no reaction from the black pointer, the complete assembly must be returned to the Manufacturer for repair. (See Service Manual.) Note: When making this test, the red pointer must be rotated to the right hand side of the scale by removing the cam and turning the cam boss by hand (counter-clockwise). This ensures that there is no restriction of the black pointer.

CONTROL BOX. The interior of the Control Box, especially the three slide bars, must be kept clean and free from grit. After cleaning the side bars they should be coated within oil.

It is advantageous to smear a small amount of molybdenumdisulphide grease in the slot of the cams. Wipe off all surplus grease after lubricating.

FLEXIBLE DRIVE CABLES. Ensure that the run of these cables is as straight as possible and that there are no kinks in the outer conduits.



Grease the conduits through the lubricators provided, ensuring that there is sufficient grease to prevent water from entering the conduits. Smear grease on the exposed ends to prevent corrosion. Remove ice in frosty weather before operating the crane.

Note:- On no account should the cables be 'bar tight'. There should be approximately ¼" of sideways movement mid- way between the pulley and the adjuster when tested with finger pressure and no noticeable 'backlash' at the pulley behind the Control Box.

MAINTENANCE. Models 4T & 5T (Telescopic Crane Units).

Maintenance operations for these Units are exactly as those laid down, in the previous pages, for Models 4, 5 & 6, with the addition of the following:-

BOOM WIRE. This cable attached to the boom head and Recoil Drum, should be regularly inspected for fraying or kinks and should be lightly greased to prevent corrosion.

Any guide pulleys along it's path should be inspected for free rotation and lubricated as necessary.

RECOIL DRUM ASSEMBLY. No maintenance is necessary apart from general cleaning and lubrication of the driving chain. This drum must apply sufficient tension to the wire to keep it taut, especially when the telescopic boom is fully retracted. If this does not operate correctly, refer to the Service Manual.

ROTARY FLEXIBLE DRIVE. Ensure that the run of this drive is as straight as possible, with no severe bends.

Inspect the knurled, screwed couplings, at each end of the drive, for tightness.

No further maintenance is necessary.

IMPORTANT:- The Serial Number of the Equipment "CO..." should be quoted in all communications and requests for service.

WEIGHLOAD AUTOMATIC SAFE LOAD INDICATOR, MK.1

MODELS 4, 5 and 6.

INSTALLATION INSTRUCTIONS

The following instructions and recommendations are given as a general guide. Mounting positions for the various components may vary on cranes of different type or manufacture but the general principle is the same in all cases.

1. For cranes with a single hoist rope used for main boom duties only or re-reeved through the jib, three main components are necessary, i.e.,
  - a. Dynamometer.
  - b. Control Box including Load Cell and Capillary.
  - c. Alarm Unit.
2. For cranes with two hoist ropes, one for main boom duties the other for jib duties, two further components are supplied:-
  - d. 2nd Dynamometer (for Auxiliary Hoist Rope).
  - e. Summator Unit.
3. Various fittings are also supplied:-
  - a. Boom Foot fittings (including Pulley).
  - b. Flexible Drive Cables, Conduits and Fittings.
  - c. Mounting Plate for Control Box.

NOTE:- The Model Number as shown on the Serial Plate on both Control Box and Dynamometer refers to the physical size and capacity of the equipment. Installation Instructions are the same for each of these models.

INSTALLING THE DYNAMOMETER.

According to the type of crane on which it is to be fitted, the Dynamometer may be rigidly mounted on the base section of the boom on on a "swinging arm" frame which allows it to follow the true path of the hoist rope, as the rope travels across the hoist drum and/or changes angle with the boom during derricking.

a. If rigidly mounted (as on most telescopic machines), the Dynamometer should be positioned so that the hoist rope is deflected as little as possible. When viewed in plan, i.e., looking down on top of the Dynamometer, it must be mounted directly on the natural line of the rope when the rope is on the center of the hoist drum. It is recommended that a string be stretched between the boom head sheave and the center groove of the drum to ascertain the correct mounting position. The largest sheave on the Dynamometer must be toward the hoist drum.

Long mounting bolts are provided for securing the Dynamometer to the members welded or clamped to the boom. These long bolts, together with the taper washers provided, allow the Dynamometer to be "jacked up" so that the rope line is as straight as possible through the unit when viewed from the side. It is essential that the mounting bolts are fully tightened and that all members are firm and rigid.

b. If the angle of the hoist rope and its distance from the boom prohibit the use of rigid mountings as described in section "a", the Dynamometer may be mounted on a "swinging arm" frame specially constructed for the purpose. Typical mounting arrangements are shown on Sketch 1. Polyurethane bumpers are usually fitted on the boom or superstructure to support the Dynamometer when the rope is slackened or during transit. The mounting position of this frame varies for each type of crane and, again, the largest sheave on the Dynamometer must be toward the hoist drum.

#### REEVING THE HOIST RAPE THROUGH THE DYNAMOMETER.

The rope is passed under the two outer rollers and over the three center rollers. This applies a slight deflection to the rope causing a load to be imparted to the Load Cell under the middle roller.

If it is not possible to pass the rope through the Dynamometer, proceed as follows:-

a. Remove the cotter pins which lock the shafts of the two outer sheaves in the side plates. With a punch or drift pin, tap out the shafts making sure that the needle roller bearing in the bores of the sheaves are not damaged in the process.

The side thrust washers and sheaves can now be lifted out.

b. Remove the bolts or studs retaining the three spacers directly above each of the three center sheaves and remove the spacers.

- c. Lay the hoist rope over these three center sheaves replace the spacers and bolts.
- d. Ensure that there is sufficient slack in the rope and replace the two outer sheaves on too of the rope ensuring that the side thrust washers are in position.
- e. Carefully re-fit the shafts, ensuring that the cotter pin holes in the shafts line up with the holes in the side plate bosses. Refit the cotter pins.

NOTE:- When supplied from the Manufacturer, the cotter pins through these shafts are unopened, enabling them to be reused.

### INSTALLING THE CONTROL BOX.

The Control Box should be positioned, as far as possible, well within the vision of the operator but allowing as straight a run as possible for the drive cable from the pulley at the rear of the box to the boom foot. Free access must be made to the door at the front of the Control Box and also to the zero adjuster and parts of line changing knob at the top of the indicator dial.

The mounting plate for the Control Box may be welded or bolted to the floor of the cab. It may be more suitable to raise the level of the Control Box for better visibility, in which case convenient spacers may be used beneath the pedestal. If spacers are used, suitable bracing may be required to make the mounting rigid.

If more convenient, the Control Box may be bolted direct to the cab structure by means of additional holes which may be drilled through the Control Box casting. It is essential, though, that the bolt heads do not foul any fixed or moving parts within the Control Box and all burrs must be removed after drilling. **NO ATTEMPT MUST BE MADE TO WELD THE CONTROL BOX DIRECTLY TO THE CAB STRUCTURE.**

A hole must be provided to allow the Load Cell to be threaded through from the Control Box to the Dynamometer. **THE CAPILLARY TUBE JOINING THESE TWO COMPONENTS IS A SEALED ASSEMBLY AND MUST NOT BE DISCONNECTED AT ANY TIME.**

The hole, therefore, must be large enough to allow the complete Load Cell to be passed through, not just the capillary. A further hole must be provided to allow the boom foot drive cable to be passed through from the Control Box to the boom foot. The holes should be on the natural run of the cable to avoid chafing, kinking and sharp bends.

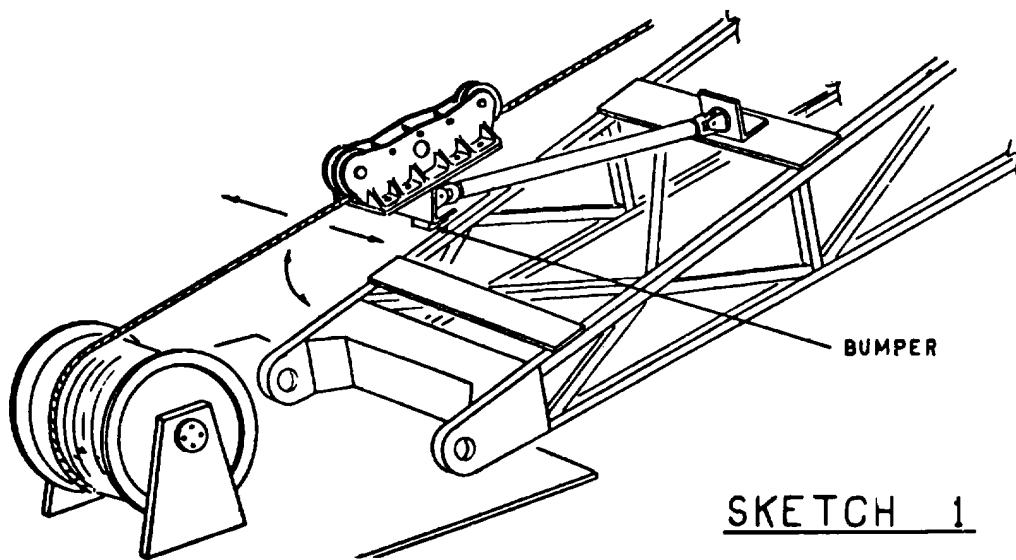
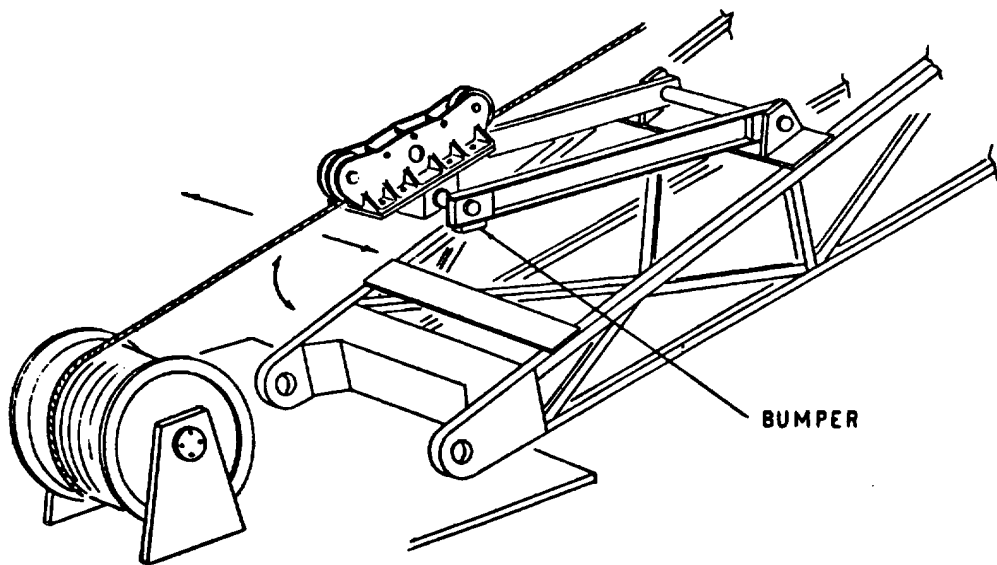
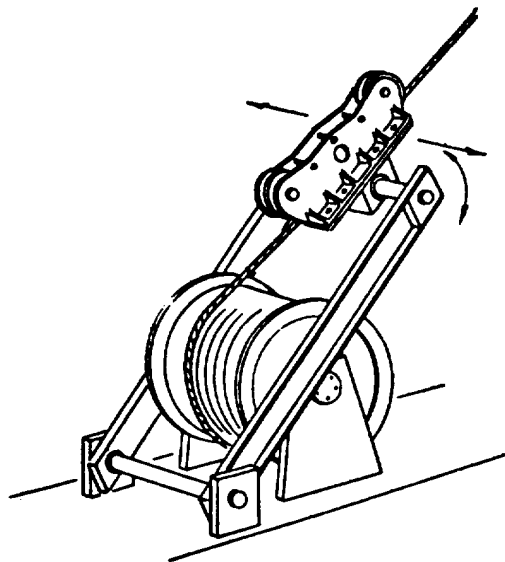

SKETCH 1

NOTE:- As the electrical supply required to operate this is a single wire, ground return circuit, it is essential that the Control Box be bonded to the frame to ensure a good ground. Should the Control Box be mounted directly onto a fibreglass cab then a separate ground wire **MUST** be fitted. **DO NOT RELY ON GROUNDING THROUGH THE CAPILLARY TUBE AND DRIVE CABLES ALONE.**

#### INSTALLING THE LOAD CELL IN THE DYNAMOMETER.

Pass the Load Cell carefully from the Control Box to the Dynamometer, ensuring that there are no sharp bends or kinks in the capillary tube and that it will not be damaged by any adjacent moving part.

Lift the center pulley and "U"-shaped block in the Dynamometer and slide the Load Cell into position so that it locates on its dowel in the Dynamometer.

IMPORTANT:- It is essential that the platform on which the Load Cell rests and also the mounting face and loading platen on the Load Cell are completely clean and free of grit when installing the Cell.

Secure the Load Cell to the Dynamometer with the two Allen head screws provided - which must be fully tightened.

NOTE:- Ensure that the Load Cell is correctly located before tightening these screws and that there is no "daylight" under the Cell.

Clip the Capillary to the structure at regular intervals along its length, especially adjacent to the Dynamometer so that the Load Cell does not have to support the weight of the hanging capillary. If the Dynamometer is on a "swinging arm" frame, ensure that there is enough slack on the capillary to accommodate the movement of the Dynamometer, looping the capillary if necessary. Also be sure there is sufficient slack in the capillary so that it will not be stretched tight around the boom foot when booming.

#### INSTALLING THE BOOM FOOT FITTING.

This assembly must be mounted in such a manner that the pulley center lays on the exact center of the boom foot pin.

A steel angle bracket is bolted to this assembly. This bracket may be welded to suitable spacers so that the center of the pulley is over the center of the boom foot pin. Keep welding clear of the area surrounding the terminating holes and slots.

Care must be taken to ensure this assembly does not foul any part of the boom or boom foot when the boom is raised or lowered.

At the extreme end of the lever arm, which is bolted to the pulley, is a turnbuckle which terminates in a small angle bracket. This bracket is welded or clamped to the boom, the turnbuckle being at right angles to the lever arm. Spacers may be needed when mounting this bracket to ensure that there is no strain on the arm during its operation. The turnbuckle is desired for adjustment purposes at a later stage.

The pulley contains alternative tapped holes, allowing the lever arm to be mounted at the required angle. Additionally, the cast bracket, when removed from the shaft, can be replaced the reverse way. Thus the assembly may be used at either the left or right hand boom foot with the cable exit either to the rear or downwards. It is most essential to ensure that during the total boom movement, the cable remains on the opposite side of the pulley, away from the bracket. As a guide, the cable should be directly opposite the bracket when the boom is at 45° to the horizontal.

Should it not be suitable to mount this assembly directly on the center line of the boom foot pin, it is possible to position it so that the level arm is parallel to but some distance away from, the boom. In this case the turnbuckle must be replaced by an arm, of adjustable length, set to the same dimension as the distance between the center of the boom foot pin and the center of the pulley. The dimension between the boom foot pin and the mounting position of this new arm on the boom must be identical with the operating length of the existing lever arm. In this way, a parallelogram is formed ensuring that the movement of the lever arm is identical to that of the boom.

On some machines, where the boom foot pin is securely fastened to the boom (and hence rotates with the boom), the pulley may be attached directly to the boom foot pin.

#### INSTALLING THE FLEXIBLE DRIVE CABLES.

Position the boom so that it is truly horizontal. Rotate the pulley at the rear of the Control Box until the actuating arm within the box is also truly horizontal. A setting hole is provided in the actuating arm which lines up with a hole in the back face of the Control Box. A 3/16" diameter rod of suitable length may now be used to lock this arm in position while the drive cable is fitted.

Now, refer to Sketch 2. Determine the routing for the boom foot cable and install deflecting pulleys where required. Run the cable and install the solderless nipples at both Sheaves. Tighten the solderless nipple at the boom foot sheave. Tension the spring about 2". Tighten the solderless nipple at the control box after ascertaining that every part is in equal tension.

REMOVE THE 3/16" ROD LOCKING THE ACTUATING ARM otherwise damage will occur during booming.

INSTALLING THE ALARM UNIT AND ELECTRICAL WIRING.

The alarm unit consists of a bell, a red light and an amber light. These must be mounted in such a position that it is plainly audible and visible to the crane operator.

Bolt the bell in position in the crane cab using the two holes provided. Mount the lights either on the bell or at any place where they are readily visible.

Remove the plastic cover from the connection box at the Control Box revealing the terminal strip. Connect one wire from the BLACK terminal to the Bell and Red light. The other terminal of the bell and red light should be connected to ground. Connect from the purple terminal to the amber warning light. (Other side of light to ground again).

Connect one more wire from the RED terminal at the Control Box to the live side of the crane's electrical supply by way of a 2-amp fuse.

Depress the test button to check functioning of the circuit. The Bell should ring and the Red light should light.

REFER TO WIRING DIAGRAM. FIG. 1.

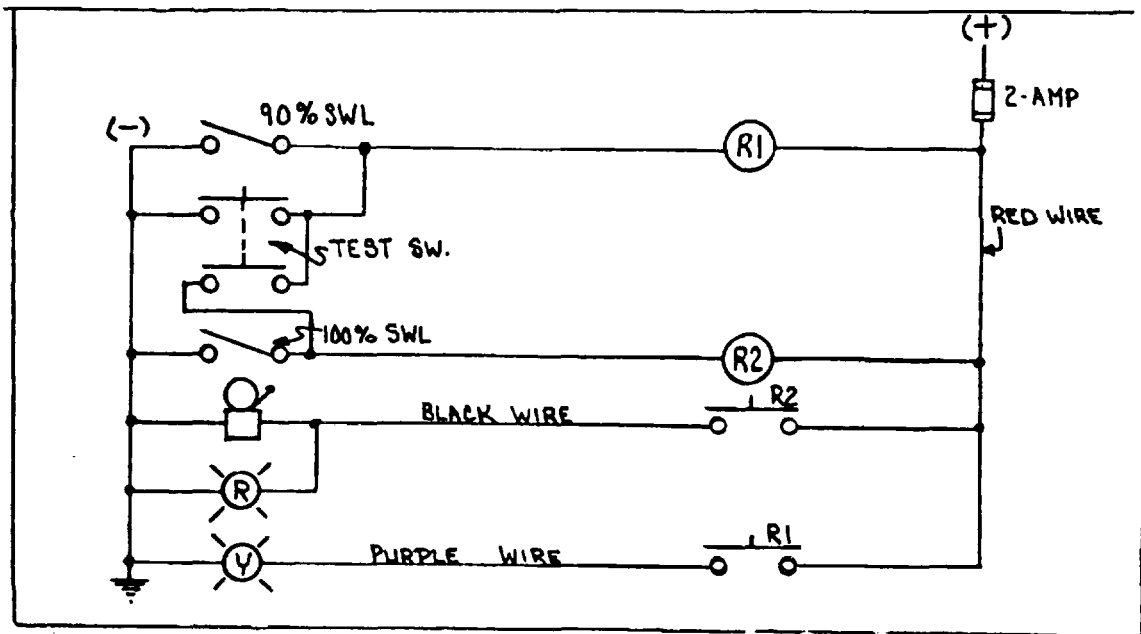



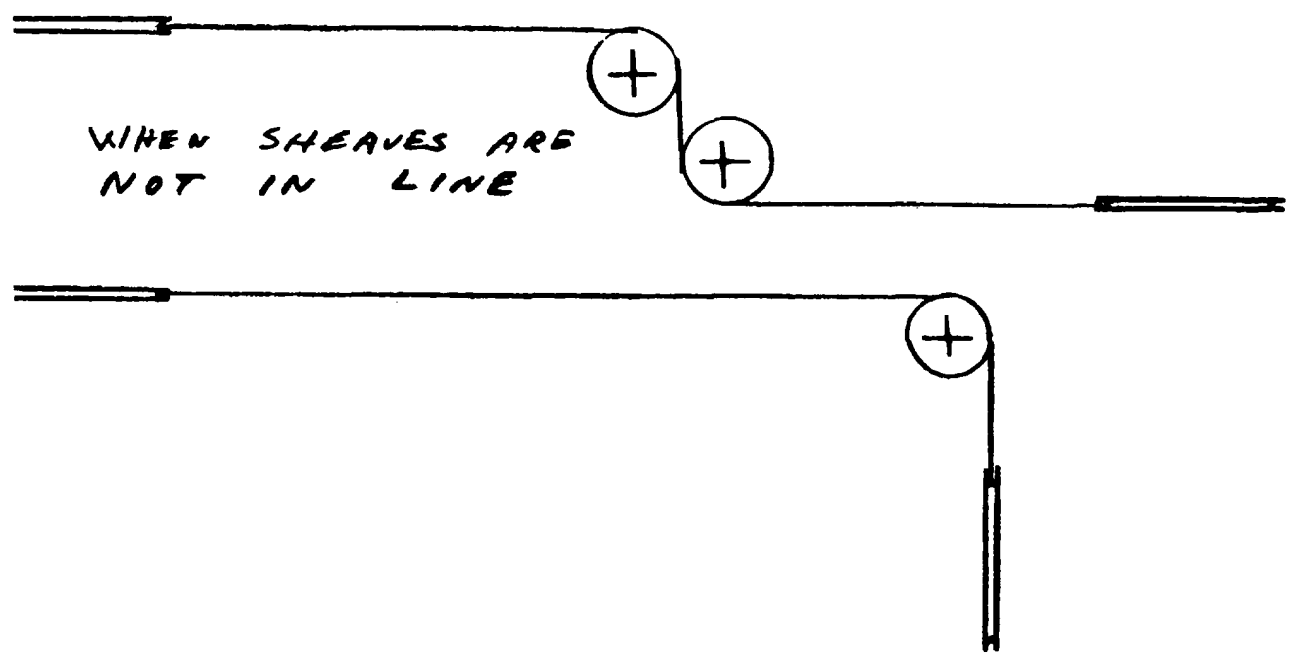
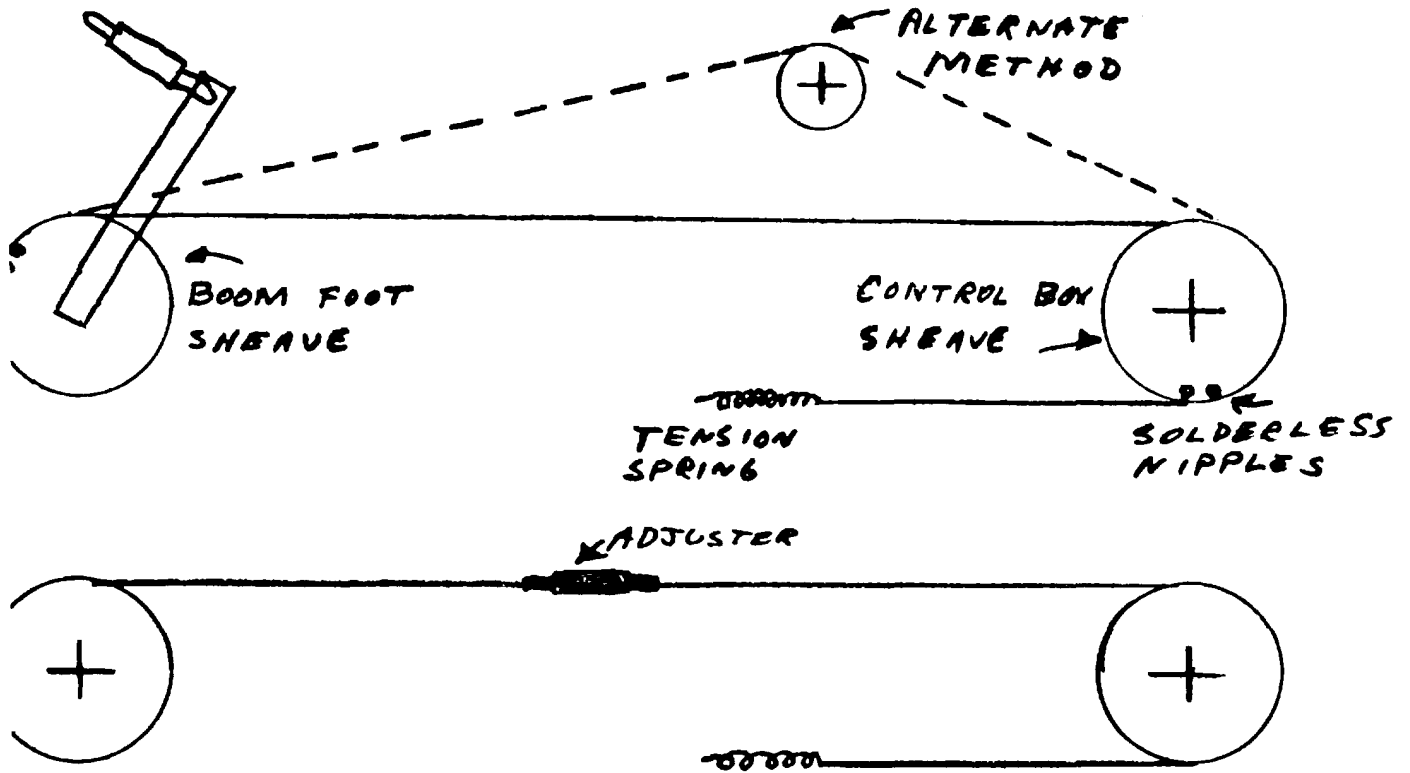

SKETCH 2

## CALIBRATION AND SETTING INSTRUCTIONS, MODELS 4, 5 & 6.

### CALIBRATING THE DYNAMOMETER.

1. Remove the cam from the Control Box and rotate the cam mounting in a counter clockwise direction so that the RED pointer is moved to the extreme right-hand side of the scale.
2. Set the BLACK pointer to read zero with the hook block resting on the ground, (Adjuster at top right-hand side of Indicator dial).
3. Rig a convenient number of parts of line, set the scale of the indicator so that the correct number of parts appear in the window on the dial. (Adjuster at top left-hand side of dial).
  - a. Hoist the maximum possible known weight within scale for that particular reeving.
5. Set the Dynamometer by rotating the long hexagonal nut in the center of the Black dial after slackening the locknut on the opposite side of the Dynamometer just sufficient to allow the long nut to be turned with a wrench. Turn this nut and shaft until the correct load reading is obtained on the black pointer in the Control Box. Tighten the locknut, lower the load so that the block is at rest and recheck the zero reading (which may have to be readjusted). Hoist the load again and recheck the black pointer reading, readjusting the Dynamometer, if necessary. Repeat this procedure until a consistently accurate reading is obtained. It is wise to "exercise" the system 5 or 6 times to be sure of the readings.

Using a 1/1" diameter drill, drill through the Black dial on the Dynamometer from the opposite side of the center block using the guide hole provided. Place the locking pin, attached to the chain, through this hole.

### SETTING THE RED POINTER READING AT THE CONTROL BOX.

- a. Rig the crane with a convenient length of boom, preferably short, and reeve the hoist rope to suit the length of boom chosen.
- b. Turn the adjuster on the dial of the Control Box so that the correct number of parts shows in the window on the dial.
- c. Fit the correct cam to the Control Box, i.e., marked with the boom length, number of parts of line and outrigger condition, (see "Operators Instructions-Adjustments") ensuring that the cam is correctly located on its boss and with the follower pin in the cam slot.

d. Hoist a known load equal to the S.W.L. at approximately half the maximum radius available for that boom length.

e. Boom OUT until this radius is obtained, using a steel tape to measure the distance NOT the crane radius indicator or Control Box radius scale (if fitted).

f. Check the RED pointer reading at the Control Box. This should indicate the Safe Working Load for that particular radius.

If this reading is incorrect the angle of the Actuating Arm in the Control Box must be adjusted by means of the turn- buckle or adjustable arm (see "Installing the Boom Foot Fitting"), until the RED pointer reading is correct. If the Boom Foot pulley is of the type with no adjustment, then this correction must be made by means of the nipple on the drive.

g. When a correct reading is obtained, boom IN until well within the working radius and then boom OUT against the tape to that radius and check the RED pointer again. Repeat this until a correct reading is obtained, adjusting the turnbuckle (or flexible drive) if necessary.

h. This procedure should be repeated at both minimum and maximum radii, hoisting the S.W.L. for each of these radii, when it should be found that only a very slight adjustment of the turnbuckle or (flexible drive) may be required at the minimum radius setting. All settings are now complete and the Indicator should be accurately set for all boom lengths.

If radius scales are fitted, these are automatically corrected by the preceding adjustments made to correct the RED pointer on the Load Indicator Scale.

It will now be found that the Amber light will light at 90% S.W.L. and the Red light will light and the Alarm will ring at 100% S.W.L.

## MODELS 4T, 5T and 6T.

### ADDITIONAL INSTALLATION INSTRUCTIONS FOR TELESCOPIC CRANE UNITS.

These instructions are additional to those given for Models 4, 5 and 6 in Data Sheets. The complete instructions given for those models apply also to units for use on Telescopic Boom Cranes.

The telescopic action of the boom must be transmitted to the Control Box to give a true indication of the working radius, as well as the Safe Working Load for that radius, as the boom extends or retracts.

The additional parts supplied are as follows:-

1. Spring Recoil Drum.
2. Stainless Steel Wire Cord. (0.080" dia.)
3. Rotary Flexible Drive.

Certain brackets and pulleys. are also required, according to the type of crane although the general method of installation is common on all Telescopic Cranes on which the Weighload Model 4T, 5T or 6T Indicator is fitted.

### INSTALLING THE SPRING MOTOR RECOIL DRUM.

The most suitable position for this drum assembly is on the superstructure under the boom hinge, mounted so that the wire cord, stowed on the drum periphery, can be passed up the entire boom without hindrance or severe deflection. (see "Installing the Boom Wire Cord"). The other factor governing the position of the Drum Assembly is the routing of the Rotary Flexible Drive from the Drum Gear Box to the Control Pox (see "Installation of Rotary Flexible Drive").

Care must be taken that the Drum Assembly is clear of all obstructions, especially the boom hoist cylinders, during operation.

When the most suitable position has been ascertained, the Drum Assembly can be bolted in position with 1/2" dia. bolts, either directly to the crane structure or to a subplate specially made for the purpose.

If it is necessary to reverse the rotation of the spring, this is achieved as follows:-

- a. Remove all screws from the large cover on the spring housing and carefully lift off the cover.
- b. If the spring is Not fitted with a retaining band, slide a suitable band over the outside diameter to retain it in its present shape, winding the drum to tighten the spring to allow this band to be fitted.

- c. Allow drum to unwind and lift the banded spring out of its housing.
- d. Slacken the screw retaining the stepped arbor, lift it off, turn it over and refit. Tighten the screw, ensuring that it locates in the indentation in the shaft.
- e. Turn the spring over and refit, passing outer eye over the anchor post and locating the inner end of the spring in the arbor recess. (Check that ratchet now works in required direction).
- f. Remove the special band, if this was not originally fitted, and replace cover and screws.

If it was found necessary to reverse the spring rotation, it will also be necessary to change the rotation of the Gear Box output shaft to which the Rotary Flexible Drive is attached. It is essential that, when looking on the end of the slotted output shaft on the Control Box, the shaft must rotate counter-clockwise when tension is being applied to the spring. This direction of rotation should be checked before installation continues. The reversing of the output shaft direction is as follows:

1. The output shaft is retained in the gear box by the bronze bearing which is screwed into the box. Unscrew this bearing to remove it, with the shaft.
2. Unscrew the bronze hexagon nut which forms a thrust cap for this shaft.
3. Screw this hexagon cap into the gear box hole from which the output shaft was removed.
  - a. Screw the bronze bearing and output shaft assembly into the gear box hole from which the cap was removed.

NOTE:- The gear box is mounted in a clamp bolted to the Drum Bracket and is held by a pinch bolt in the clamp. Slackening this pinch bolt allows the gear box to be rotated so that the output direction is as required.

IMPORTANT:- After slackening this pinch bolt, ensure that the gear box is pushed hard against its shoulder in the clamp before re-tightening the pinch bolt. Ensure that the bronze bearings and thrust cans are fully tightened in the gear box housing and also the pinch bolt is fully tightened.

## INSTALLING THE STAINLESS STEEL WIRE CORD.

The object of this cord is to rotate the Recoil Drum as the boom is telescoped, thus measuring the length of boom extended at all times.

The most suitable path for this cord is along the outside side of the boom anchored, at its free end, to the extreme end of the final telescoping section, Not to the manual section. The anchorage should be of the spring, shock absorber type to reduce the snatch on the cable when telescoping commences. Another anchorage may be needed (Point section extended and jib cams are cut for angle ratings. When these cams are used, boom extension wire must be fastened at a point 3 foot back of the normal position. This will bring the wire to the base section of boom and reel will not extend with the boom. Ratings are then proportioned to angle.)

Suitable cleats should be provided along the boom to provide adequate guiding and protection of the cord.

At the root section, adjacent to the boom hinge, one or two deflector pulleys may be required to direct the cord to the Recoil Drum. These pulleys should be as free running as possible, preferably on needle roller bearings. Careful positioning of the deflector pulley, or pulleys, will reduce the error caused during booming to negligible limits although, it will be found that the optimum position for the pulley is, as near as possible, directly on the center of the boom hinge pin.

It is also important to ensure that the cord does not come out of the groove of the pulley when the boom is fully derricked in. Moving the Recoil Drum forward will improve this condition but, if necessary, the cord may be passed once round the pulley to keep it in engagement.

The deflector pulley should be far enough away from the Recoil Drum to allow the cord to coil correctly on the drum without "bunching". Introducing shims under the Drum mounting to tilt the assembly will assist the coiling should difficulty be met.

## TO SET THE DRUM TENSION AND BOOM CORD.

1. Before assembling the Boom Cord to the Recoil Drum, rotate the drum periphery until it is fully wound up (spring solid). Apply a suitable sprag.
2. Fully extend the boom. The manual extension may be in or out. (Outriggers should be out).
3. Attach the Boom Cord to the periphery of the Recoil Drum, passing the end through the hole in the periphery and securing it with a solderless nipple within the periphery. Two holes are provided to suit the direction of the rotation of the drum.

4. Rotate the drum one revolution to relieve the spring from its solid state and then wind two coils of cord around the periphery, coiling them close to the side of the drum. Sprag the drum against accidental rotation.

5. Pass the boom wire over the deflector pulley/s and through the cleats on the boom to an anchorage provided at the last powered section.

6. Fully retract the boom checking the operation of the drum during the whole operation. The spring tension on the drum must hold the boom cord taut at all boom extensions. If the boom cord is wrapped one turn around a deflector pulley, it must be examined during the operation. If "scuffing" occurs, this can be improved by reversing the coil, i.e., "right-over- left" instead of "left-over-right".

7. Check the direction of rotation of the output shaft in the gear box of the Recoil Drum. When looking on the end of the slotted shaft, the shaft MUST rotate counter-clockwise as the boom is telescoped OUT. (See "Installing the Spring Motor Recoil Drum").

#### INSTALLING THE ROTARY FLEXIBLE DRIVE, AND SETTING.

These drives are supplied in various lengths to suit the individual types of crane. The length chosen should ensure that the path of the drive is as natural as possible and with- out sharp bends. When installed it should be clipped in place to support it and provide protection against other moving parts on the superstructure. Both ends, at the Control Box and Recoil Drum, should be supported so that the weight of the drive is not hanging on the end couplings.

Do not tightly clip the drive at the Control Box end as the conduit must be allowed to rotate through approx. 90°.

To install and set, proceed as follows:-

a. Fully extend the boom. The manual section may be in or out. (Outriggers should be out).

b. Connect the Rotary Flexible Drive to the Gear Box out- put shaft on the Recoil Drum, by locating the tongue on the Flexible Drive in the slot in the output shaft. Fully tighten the screwed retaining sleeve.

b. By hand, rotate the squared shaft protruding from the center of the pulley shaft at the rear of the Control Box, until the bronze nut in the actuating arm within the Control Box, is registered against the maximum boom length, i.e., when the cursor mark on the nut lines up the maximum length on the actuating arm scale.

d. Connect the driven end of the Rotary Flexible Drive to the squared shaft at the back of the Control Pox and fully tighten the screwed retaining sleeve.

Check the operation of this drive, especially that the direction of the nut in the actuating arm is correct, i.e., the nut should move toward the center hub of the arm when the boom is retracted.

All settings are now complete and reference must be made to Data Sheets. (Installation Instructions) for general calibration and testing.

**2-1-22**



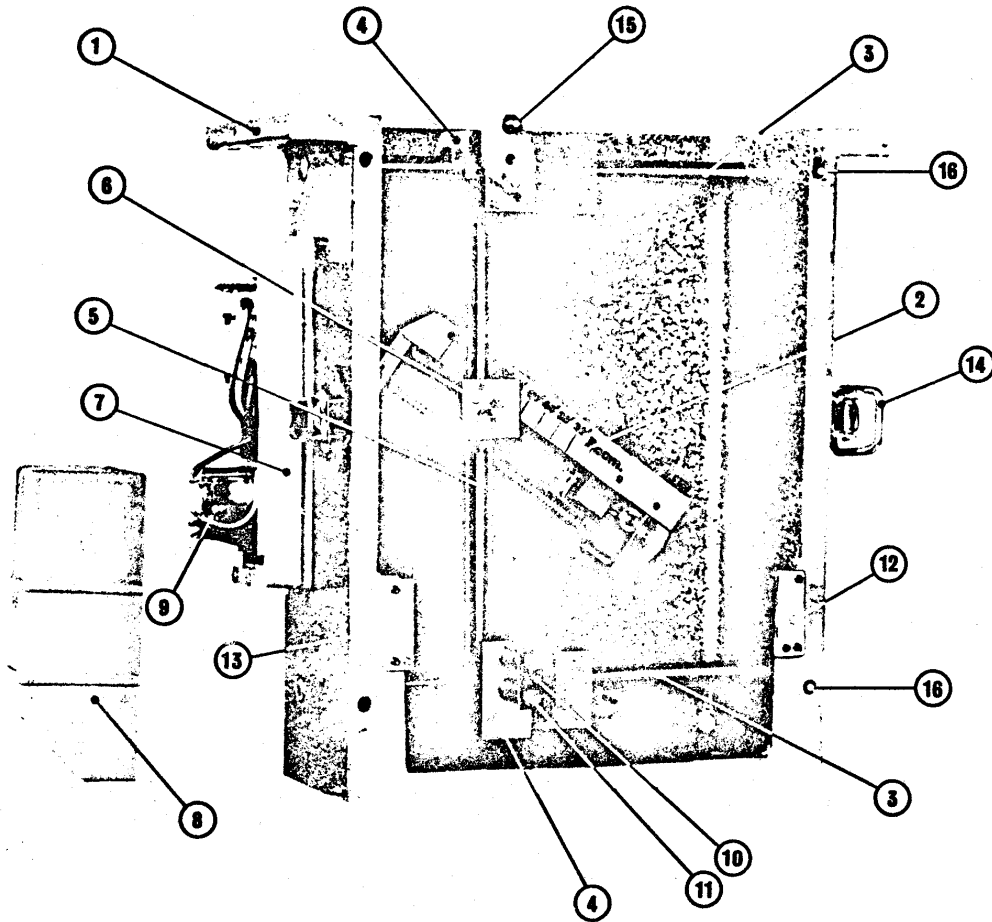

**TELESCOPIC CONTROL BOX  
MECHANICAL ASSEMBLY**

- |                             |                                 |
|-----------------------------|---------------------------------|
| 1. Case                     | 9. Relay                        |
| 2. Telescopic Actuating Arm | 10. Radius Pointer & Screws     |
| 3. Slide Bar                | 11. Packing Tubes               |
| 4. Slide Block              | 12. Radius Plate Housing (R.H.) |
| 5. Actuating Bar            | 13. Radius Plate Housing (LH.)  |
| 6. Actuating Block          | 14. Toggle Fastener             |
| 7. Relay Base               | 15. Cam Follower                |
| 8. Relay Cover              | 16. Grub Screw                  |

IMPORTANT

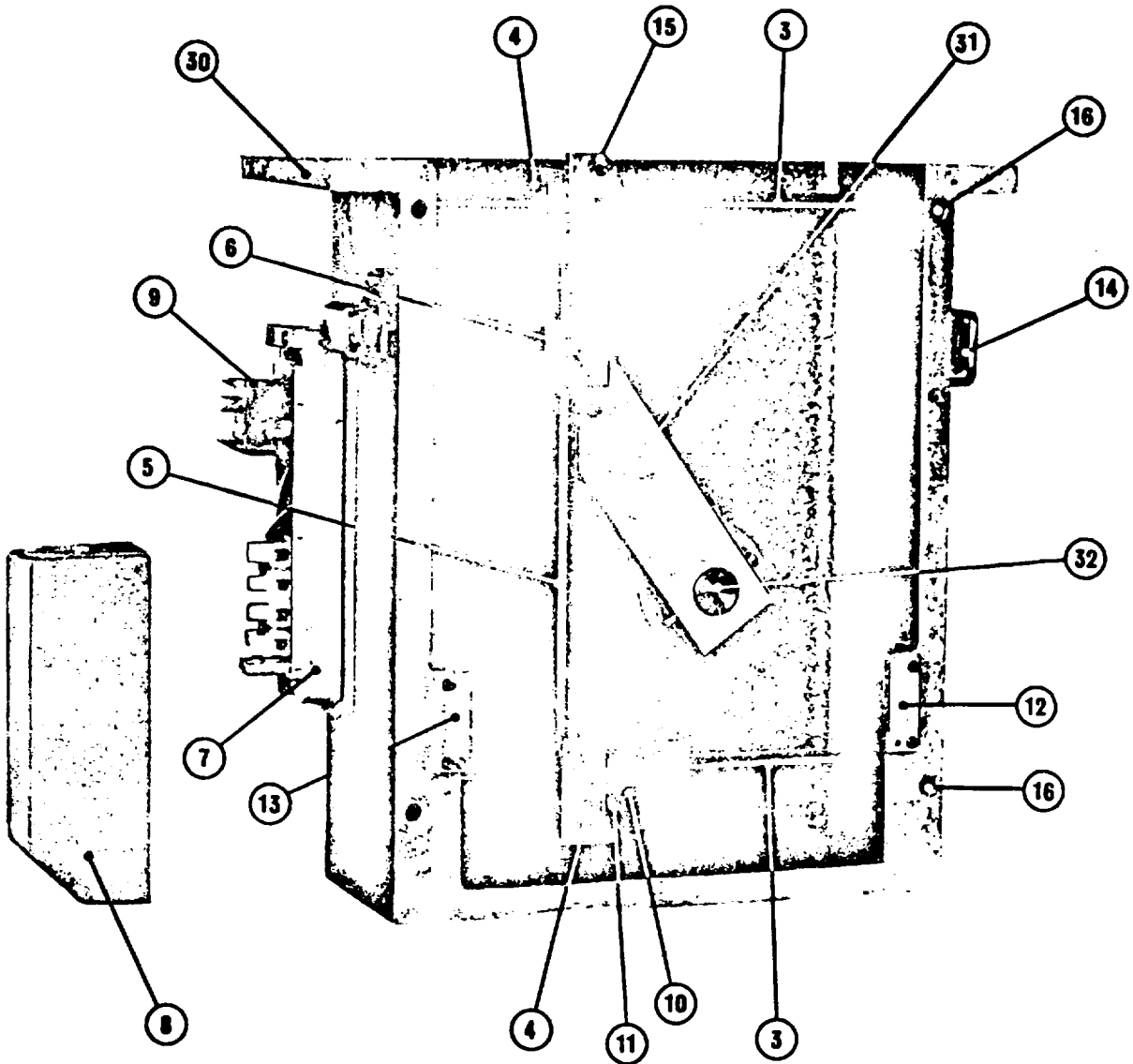

**STRUT JIB CONTROL BOX  
MECHANICAL ASSEMBLY**

- |                            |                                 |
|----------------------------|---------------------------------|
| 3. Slide Bar               | 12. Radius Plate Housing (R.H.) |
| 4. Slide Block             | 13. Radius Plate Housing (L.H.) |
| 5. Actuating Bar           | 14. Toggle Fastener             |
| 6. Actuating Block         | 15. Cam Follower                |
| 7. Relay Base              | 16. Grub Screw                  |
| 8. Relay Cover             | 30. Case                        |
| 9. Relay                   | 31. Actuating Arm               |
| 10. Radius Pointer         | 32. Pivot Pin                   |
| 11. Packing Tubes & Screws |                                 |

**IMPORTANT**

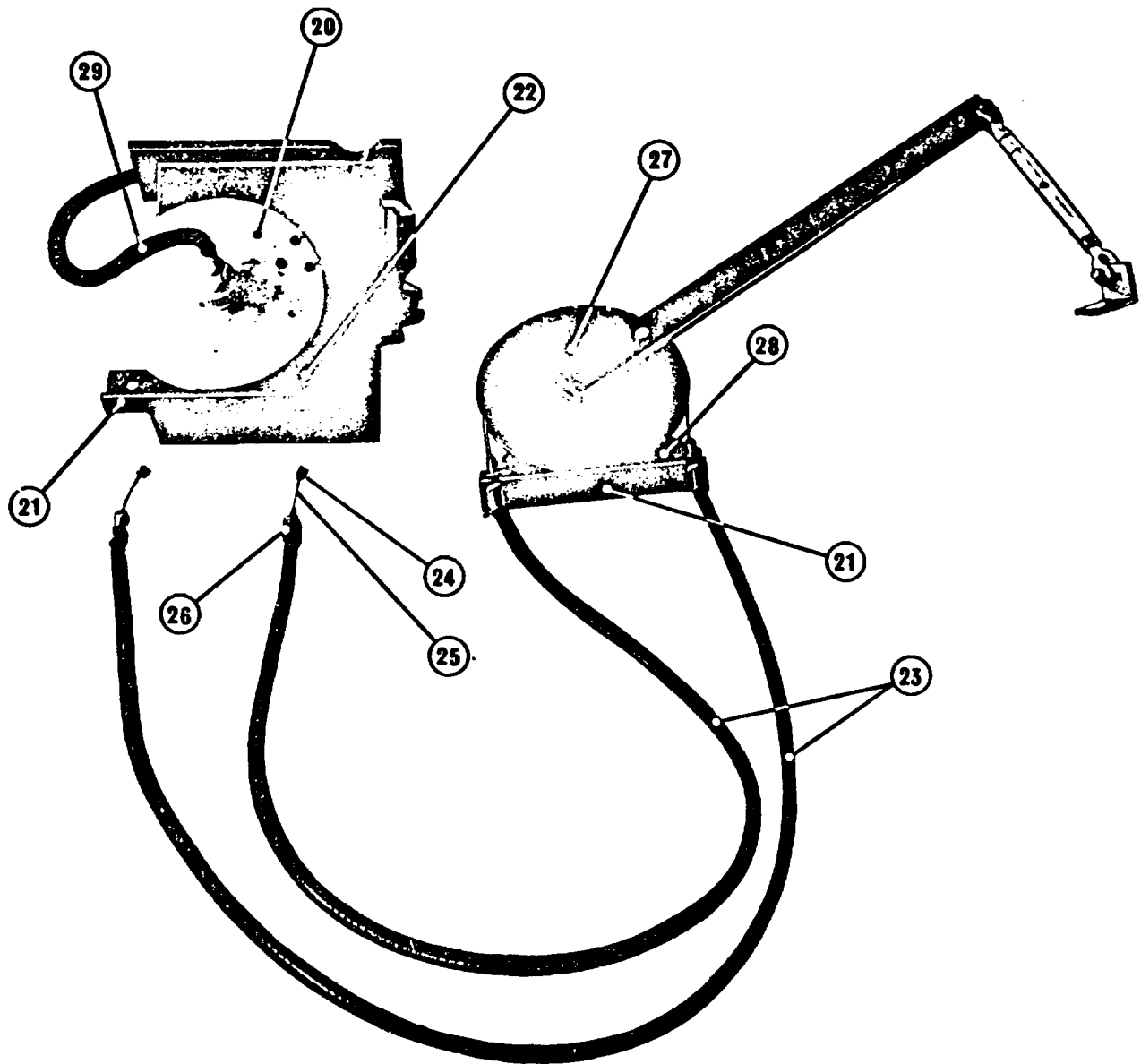

**TELESCOPIC CONTROL BOX  
DRIVE ASSEMBLIES**

- |                          |                                 |
|--------------------------|---------------------------------|
| 20. Driven Pulley        | 25. Flexible Drive Cable        |
| 21. Anchor Bracket       | 26. Adjusting Stop              |
| 22. Anchor Bracket Bolts | 27. Drive Pulley                |
| 23. Conduit              | 28. Bearing Bracket             |
| 24. Trunnion             | 29. Rotary Flexible Drive Shaft |

**IMPORTANT**

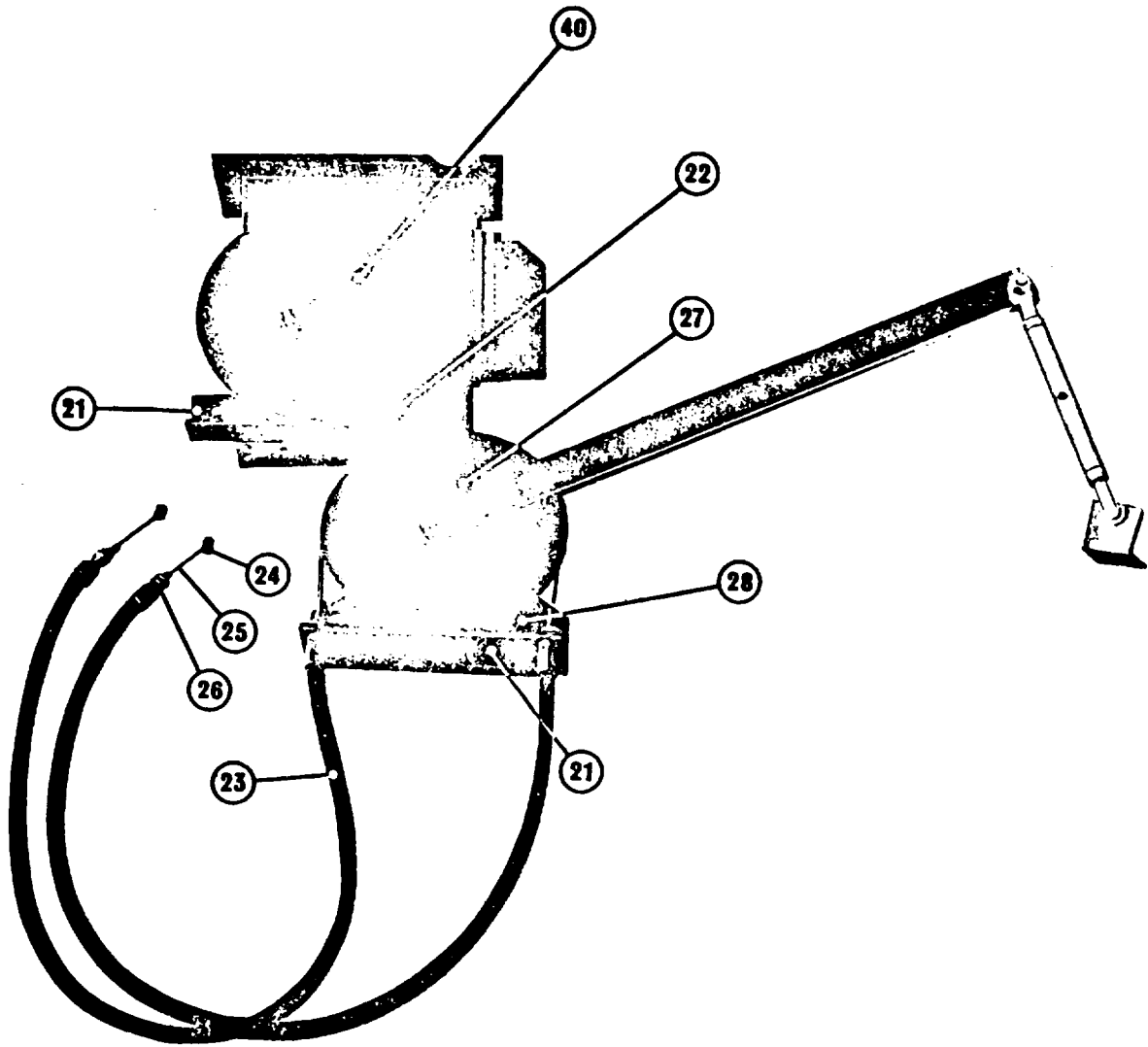

**STRUT JIB CONTROL BOX  
DRIVE ASSEMBLIES**

- |                         |                    |
|-------------------------|--------------------|
| 21 Anchor Bracket       | 26 Adjusting Stop  |
| 22 Anchor Bracket Bolts | 27 Drive Pulley    |
| 23 Conduit              | 28 Bearing Bracket |
| 24 Trunnion             | 40 Driven Pulley   |
| 25 Flexible Drive Cable |                    |

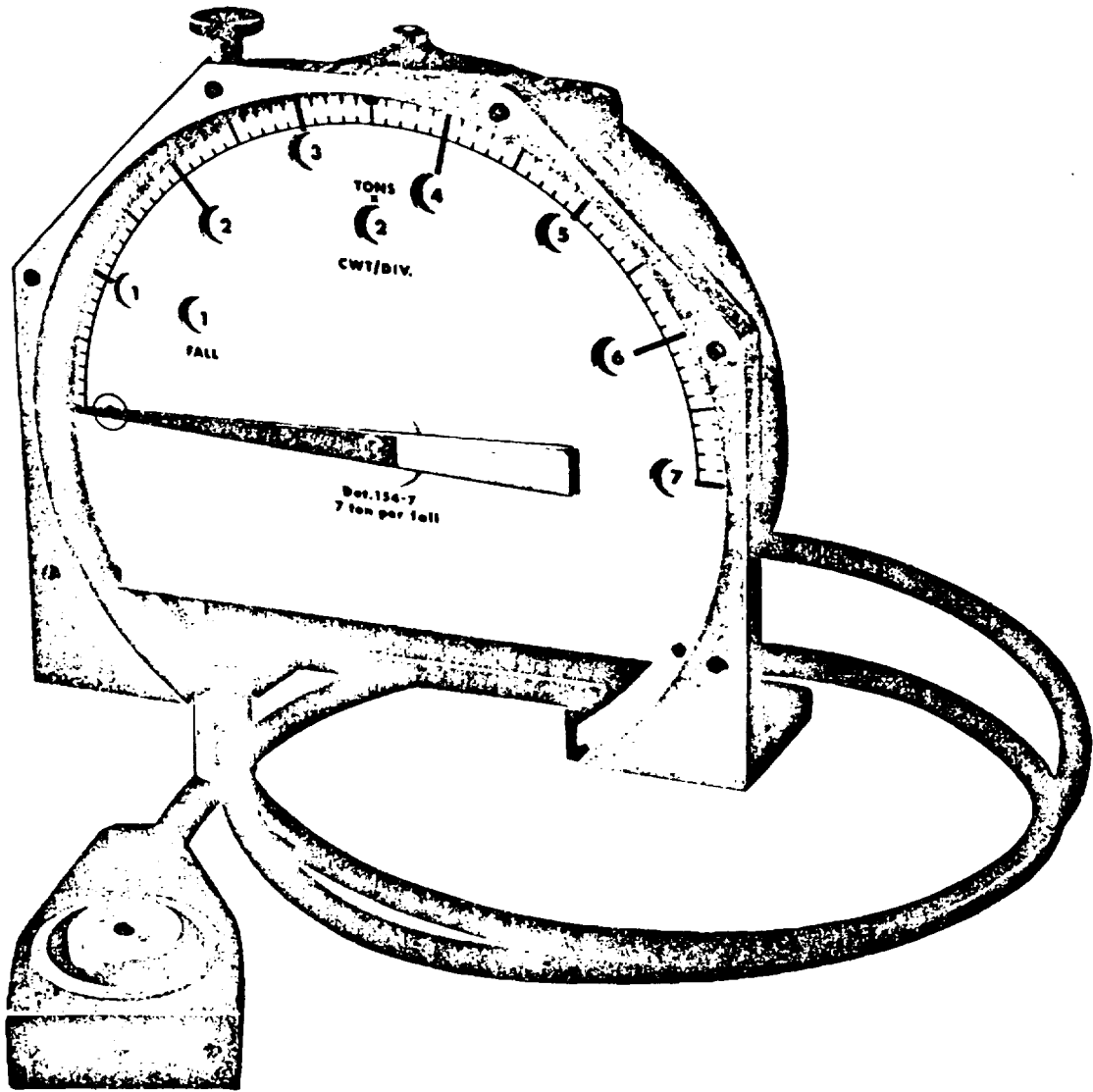

INDICATOR & LOAD CELL ASSEMBLY  
REFERENCE 35

2-1-27

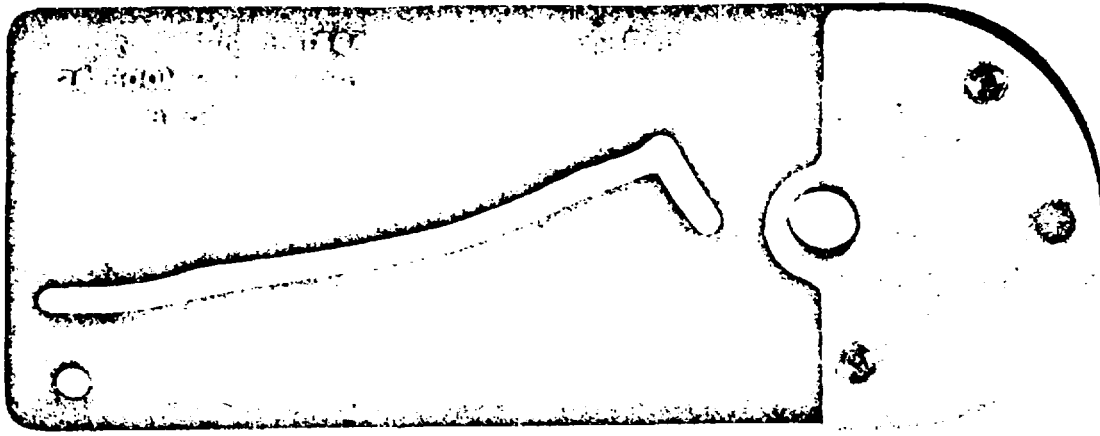

**REF 36**

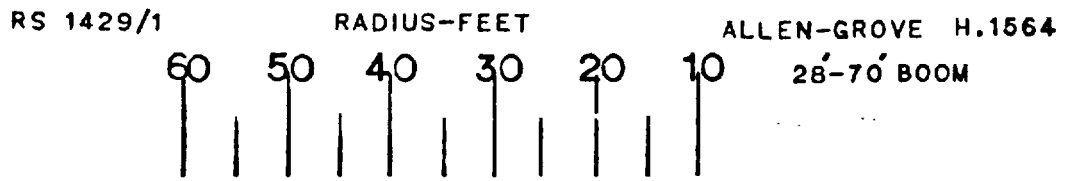

**REF 37**

**CAM ASSEMBLY  
REFERENCE 36 (SPECIFY DUTY)**

**RADIUS SCALE  
REFERENCE 37 (SPECIFY BOOM LENGTH)**

2-1-28

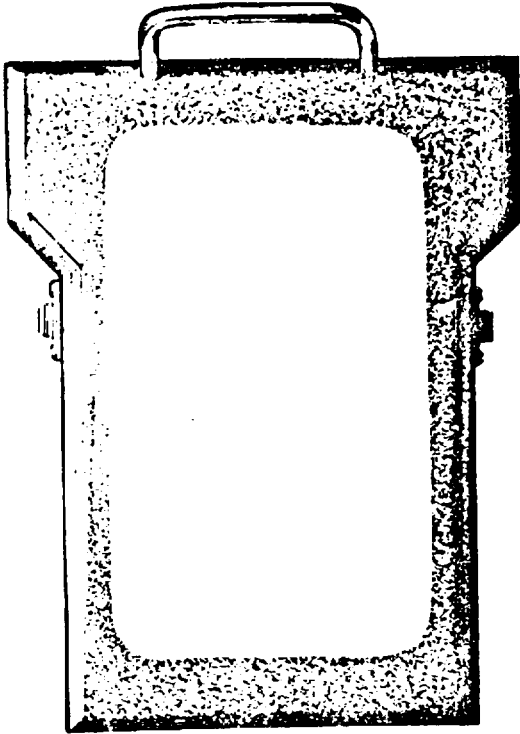

**REFERENCE 38**

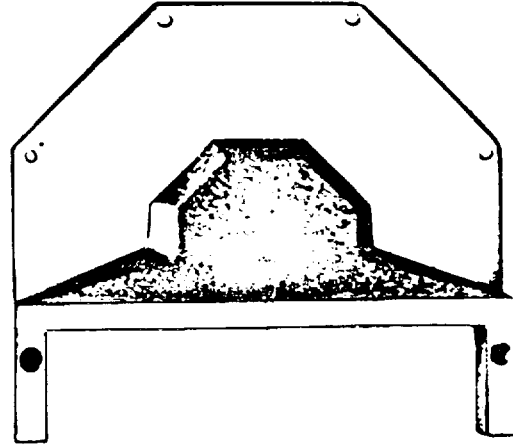

**REFERENCE 39**

**DOOR ASSEMBLY  
REFERENCE 38**

**TOP COVER ASSEMBLY  
REFERENCE 39**

**2-1-29**

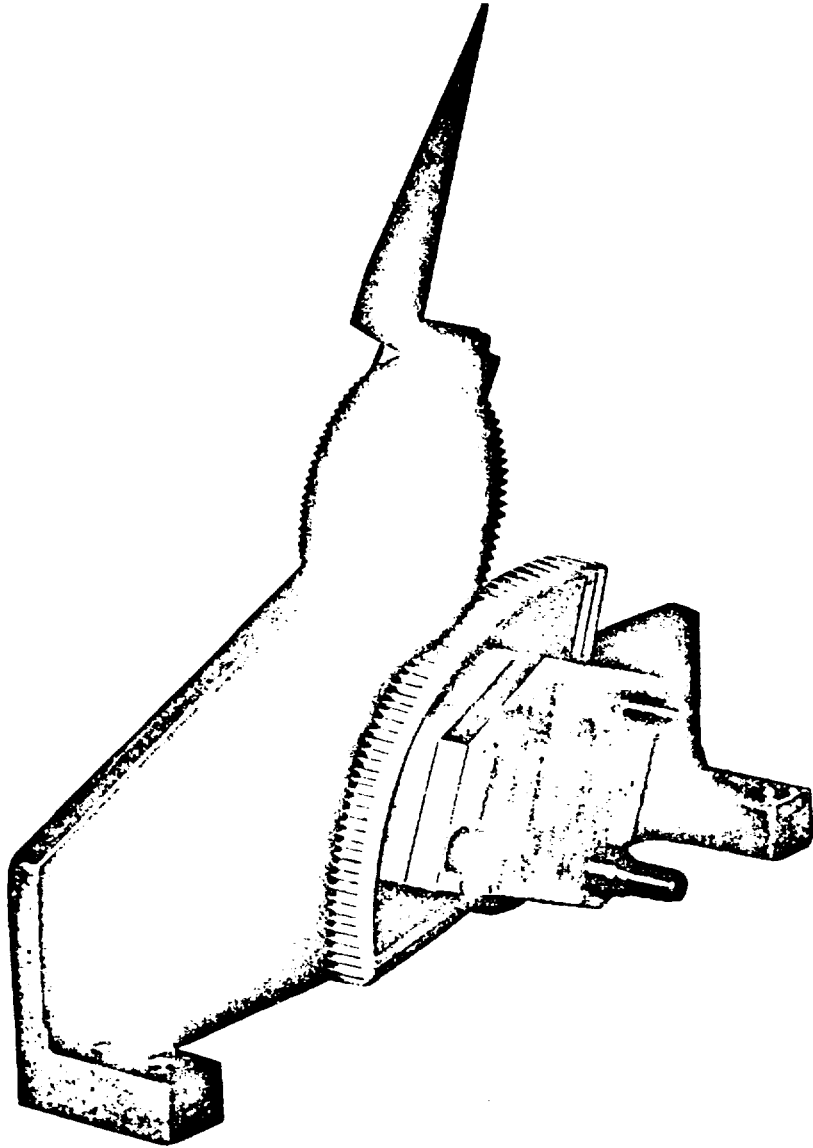

GEAR PLATE ASSEMBLY  
REFERENCE 44

2-1-30



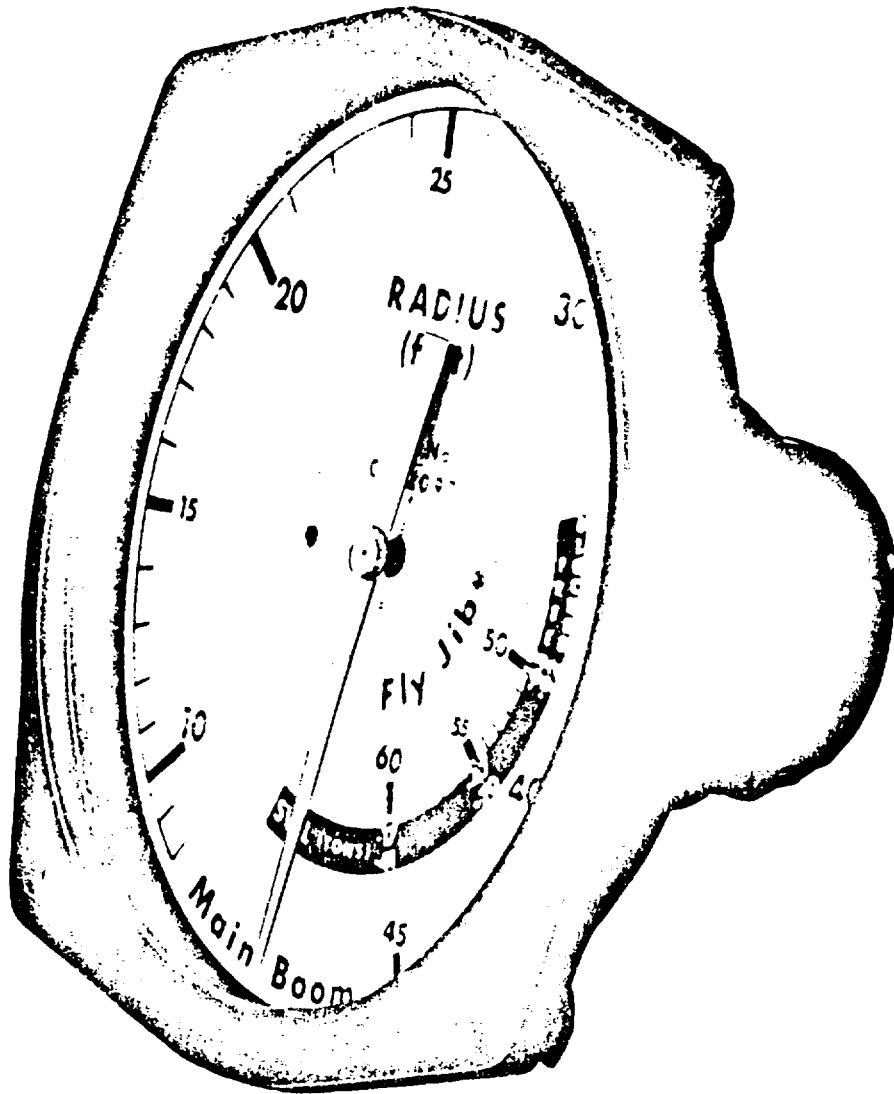

REMOTE RADIUS INDICATOR 12V or 24V  
REFERENCE 57

IMPORTANT

2-1-31

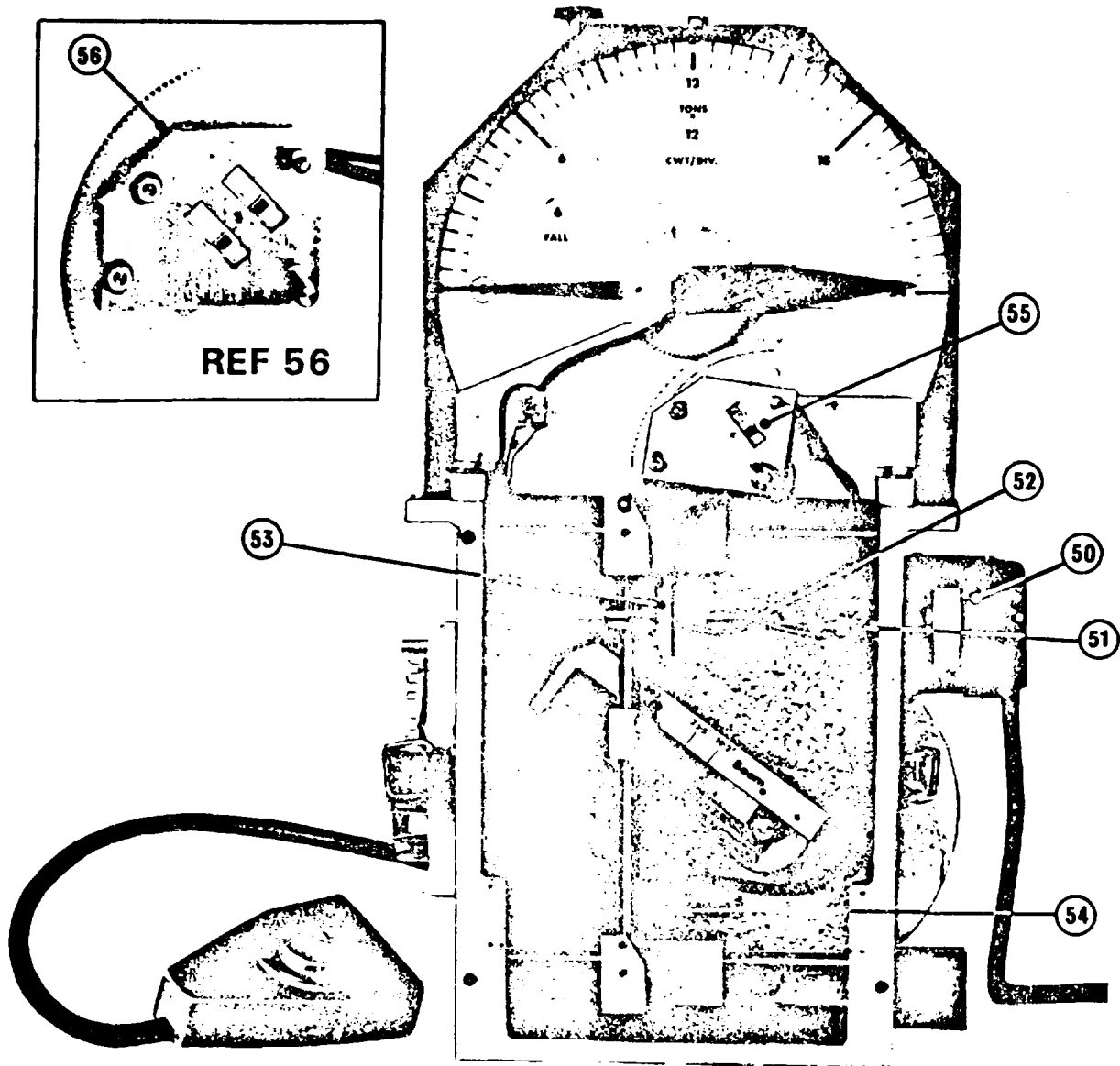

**SPECIAL REFINEMENTS**  
**(A) REMOTE RADIUS INDICATOR UNIT**  
**(B) SLEW AND DERRICK LIMIT INTERLOCKS**

- |                                  |  |
|----------------------------------|--|
| 50 Radius Transmitter 12v or 24v | 54 Derrick Limit Switch  |
| 51 Drive Coupling                | 55 Special Segment Assembly<br>c/w Derrick Limit<br>Interlock Switch |
| 52 Spiral Drive Strip            |  |
| 53 Nut Bracket                   |  |

**REFERENCE 56 (INSERT)**

Special Segment Assembly c/w Derrick and Slew Limit Interlock Switches.

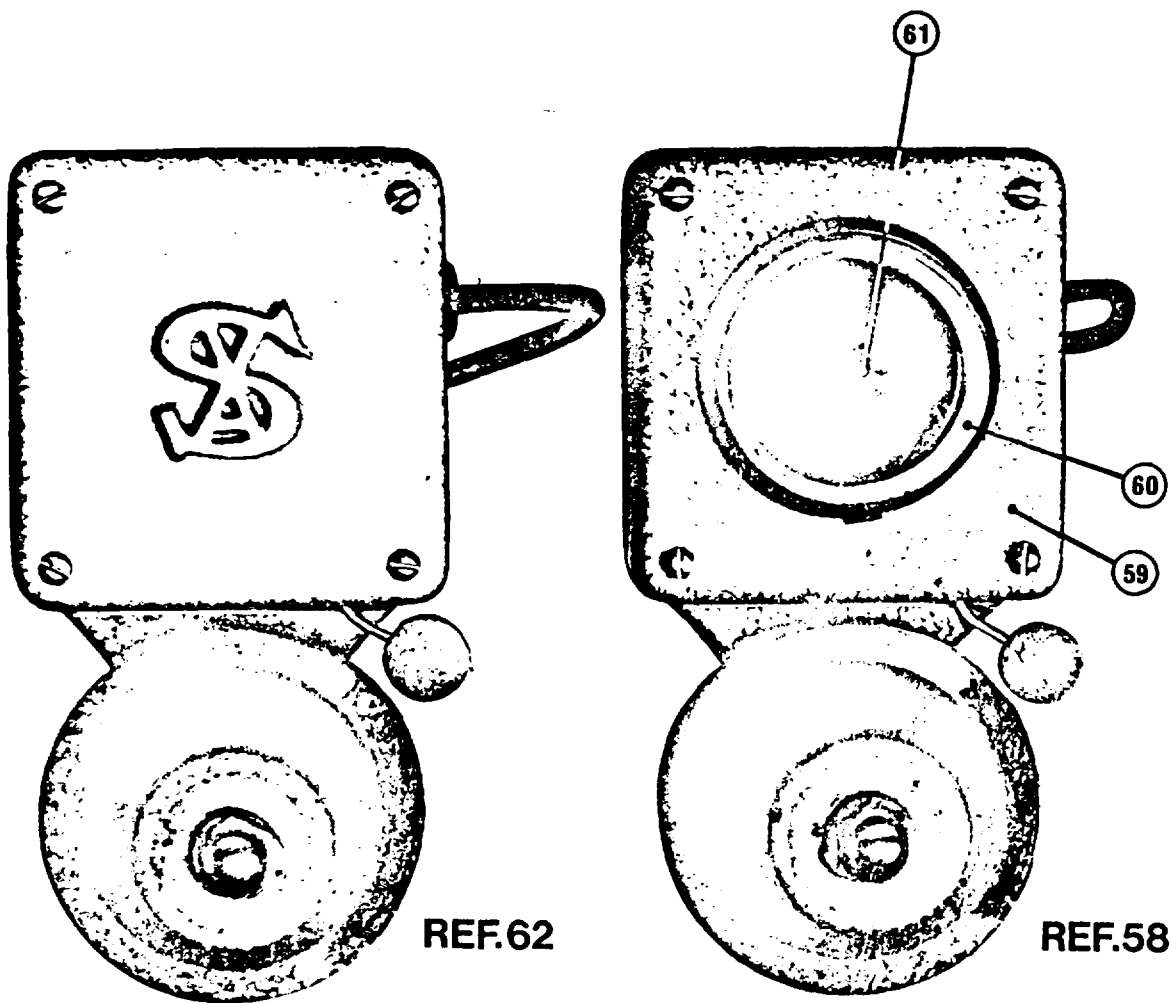

**BELL AND LIGHT WARNING BOX  
REFERENCE 58. 6V,12V OR 24V**

59. Bell Unit Complete, including  
Lamp Base.

60. Lamp Glass & Bezel  
61. Festoon Bulb

**BELL WARNING BOX  
REFERENCE 62. 6V,12V OR 24V**

**IMPORTANT**

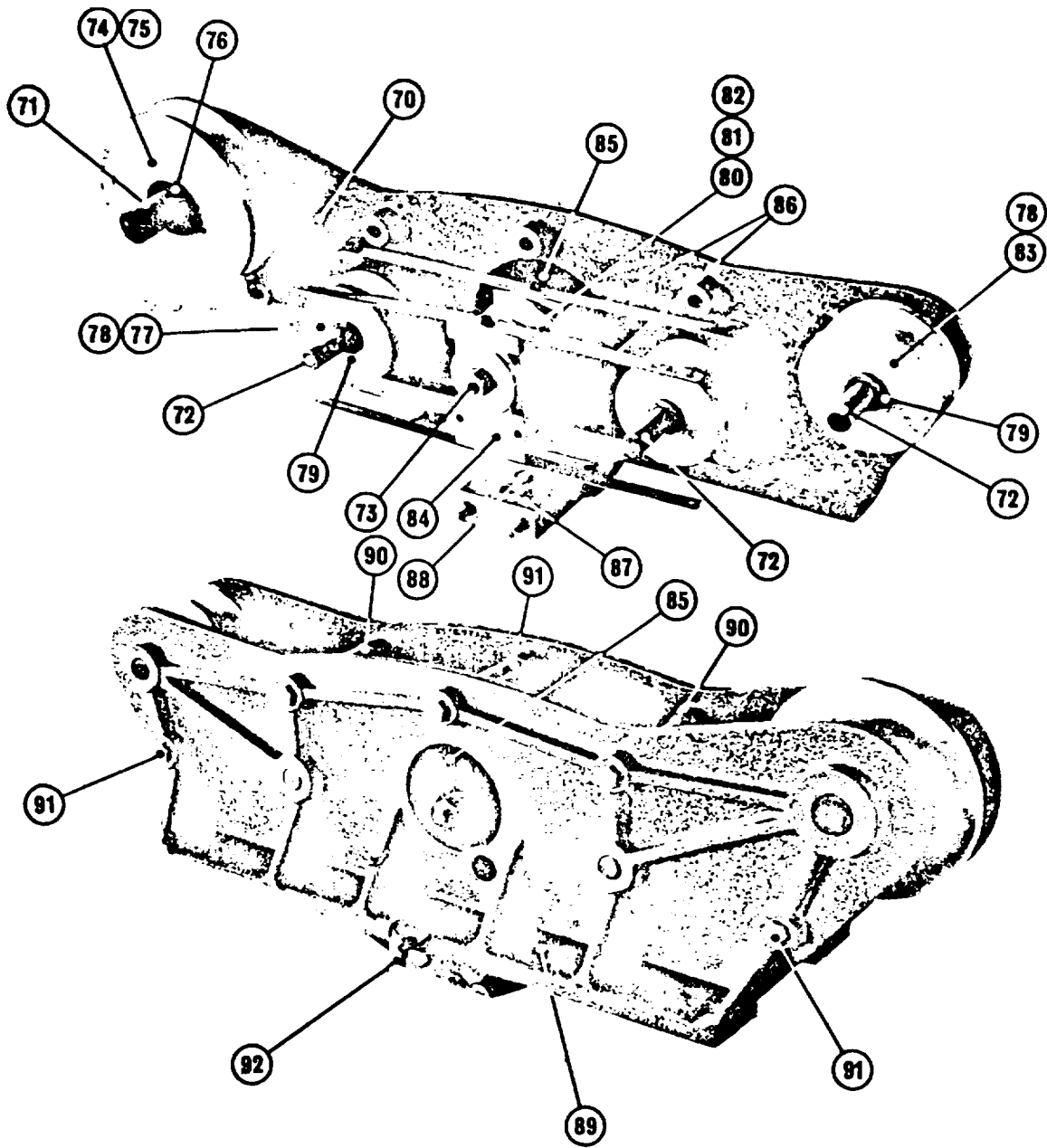

**DYNAMOMETER**

- |                                   |                                  |
|-----------------------------------|----------------------------------|
| 70 Sideplate (L.H.)               | 82 Loading Roller Thrust Washers |
| 71 Drum End Spindle               | 83 Sheave End Roller             |
| 72 Roller Spindle                 | 84 Loading Fork Assembly         |
| 73 Eccentric Spindle              | 85 Reeving Dial                  |
| 74 Drum End Roller                | 86 Flexible Strip                |
| 75 Drum End Roller Bearings       | 87 Loading Plate                 |
| 76 Drum End Roller Thrust Washers | 88 Locator                       |
| 77 Centre Roller                  | 89 Sideplate (R.H.)              |
| 78 Centre Roller Bearings         | 90 Spacer (Centre Roller)        |
| 79 Centre Roller Thrust Washers   | 91 Spacer (Standard)             |
| 80 Loading Roller                 | 92 Lockpin                       |
| 81 Loading Roller Bearings        |                                  |

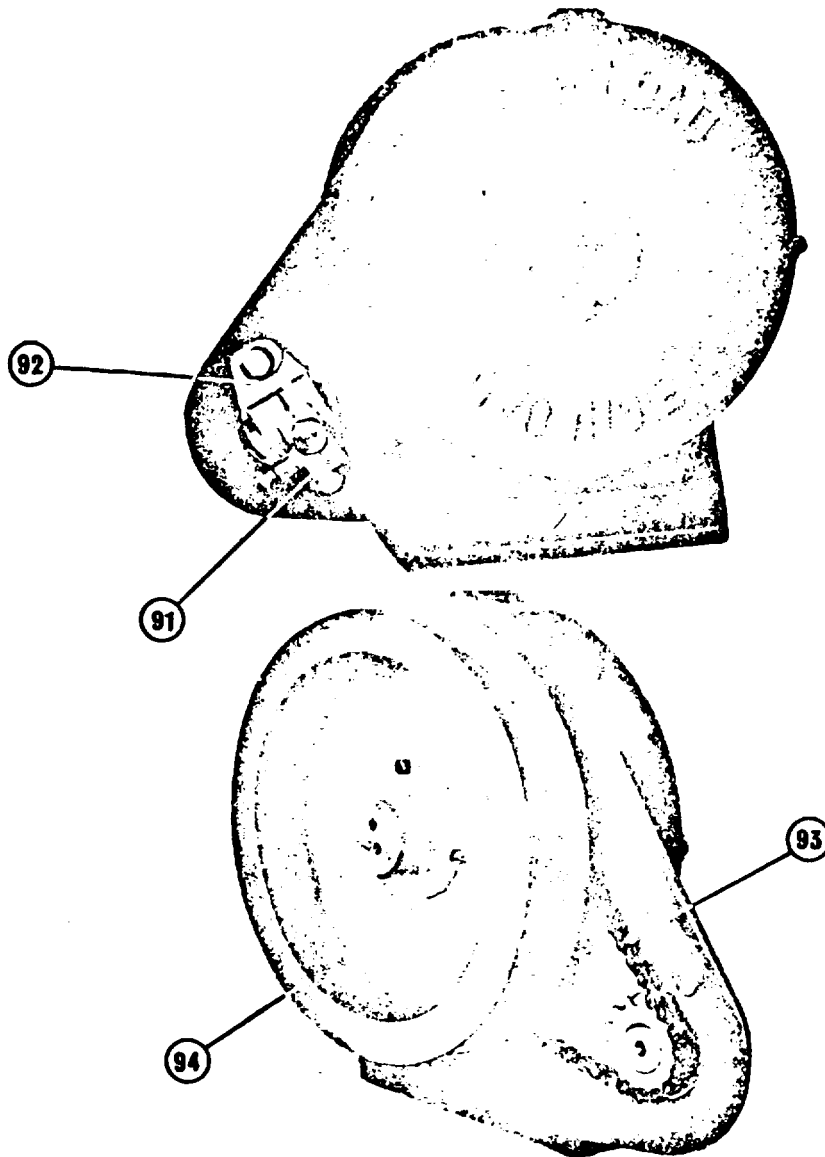

**RECOIL DRUM ASSEMBLY  
REFERENCE 90**

91 Gear Box  
92 Gear Box Clamp

93 Chain  
94 Periphery

**IMPORTANT**

**2-1-35/(2-1-36 (blank))**

**PART THREE**

**SUPPLEMENTAL MAINTENANCE AND REPAIR PARTS INSTRUCTIONS**

## TABLE OF CONTENTS

			<b>Page No.</b>
Section	I	INTRODUCTION	
Paragraph	1-1	Scope	3-1-1
	1-2	MILSTRIP Requisition Identification and Control	3-1-1
	1-3	Maintenance Forms and Records	3-1-2
Appendix	1-A	Non-NSN, MILSTRIP Requisition for CCE, Sample Format	3-1-3
	1-B	NSN, MILSTRIP Requisition for CCE, Sample Format	3-1-4
Section	II	MAINTENANCE SUPPORT PLANNING DATA	
Paragraph	2-1	Purpose	3-2-1
	2-2	Description	3-2-1
	2-3	Procurement Status	3-2-2
	2-4	MOS Requirements	3-2-2
	2-5	Logistics Assistance (AR 700-4)	3-2-2
	2-6	Maintenance Concept	3-2-2
	2-7	Maintenance Allocation Chart	3-2-3
	2-8	Modifications	3-2-3
	2-9	Equipment Improvement Recommendations (EIRs)	3-2-3
	2-10	Shipment and Storage	3-2-3
	2-11	Destruction to Prevent Enemy Use	3-2-3
	2-12	Basic Issue Item List	3-2-3
	2-13	Special Tools and Equipment	3-2-3
	2-14	Maintenance and Operating Supplies	3-2-3
	2-15	Maintenance Forms and Records	3-2-3
	2-16	Warranty	3-2-4
Appendix	2-A	Maintenance Allocation Chart	3-2-11
	2-B	CCE Manufacturer's Field Campaign and Modification Procedures	3-2-33
	2-C	Basic Issue Item List and Items Troop Installed or Authorized List	3-2-35
	2-D	Maintenance and Operating Supply List (CCE)	3-2-39
	2-E	Preventive Maintenance Checks and Services	3-2-43

Section	III	REPAIR PARTS SUPPLY	Page No.
Paragraph	3-1	General	3-3-1
	3-2	Prescribed Load List (PLL)	3-3-1
	3-3	Authorized Stockage List (ASL)	3-3-1
	3-4	Requisitioning Repair Parts	3-3-1
	3-5	Submitting Requisitions	3-3-2
	3-6	DA Equipment Publications	3-3-2
Appendix	3-A	Prescribed Load List (PLL) Authorized Stockage List (ASL)	3-3-3



## **SECTION I INTRODUCTION**

### **1-1. SCOPE**

The instructions in Part 3 are for:

- a. The use of the personnel to whom the end item is issued.
- b. Maintenance personnel responsible for maintaining and/or repairing the end item.
- c. Supply personnel responsible for requisitioning and stockage of repair parts.

### **1-2. MILSTRIP REQUISITION IDENTIFICATION AND CONTROL**

- a. Parts Requisition Identification and Control.

(1) Since only limited repair parts will be initially provisioned, it is necessary to provide a method for supplying parts which were not initially provisioned. When necessary to come to the wholesale level for supply, all non-NSN requisitions (CONUS or Overseas) will be directed through Defense Automatic Address System (DAAS) to DCSC for supply. Visibility of these non-NSN items will be maintained, NSN's obtained, and the items stocked when warranted by sufficient demands.

(2) Identification and control of CCE crane requisitions will be by a combination of project and weapon system codes. Where applicable in accordance with existing procedures, CCE crane requisitions will follow the Direct Support System (DSS). Both a CCE (DSS) project code and a unique weapon system code have been assigned to the CCE crane. The purpose and intended use of the CCE (DSS) project code is to enable DSA to identify the end item contract and manufacturer for supply action of non-NSN parts that DSA will take in support of the CCE crane. National stock numbered parts will be requisitioned using the standard supply system and applicable assigned DSS codes or in the case of a non-DSS unit, the normal supply channels. The appropriate weapon system code will be used on every parts requisition (NSN or non-NSN). Entry of the weapon system code will provide supply management information to the Logistic Intelligence File (LIF) for the CCE crane.

(1) CCE (DSS)

CODE

DEFINITION

XDY  
(USAREUR)

Indicates the requisition is in support of the CCE Crane and designates parts shipments to the East Coast Consolidation/Containerization Point (CCP) (New Cumberland Army Depot).

XDM  
(USARPAC)

Indicates the requisition is in support of the CCE Crane and designates parts shipments to the West Coast Consolidation/Containerization Point (Sharpe Army Depot).

XDP  
(CONUS)  
(USARAL)  
(USARSO)

Indicates the requisition is in support of the CCE Crane but will be treated as non-DSS. parts shipments will be made directly from Depot/Vendor to requisitioners.

(2) Weapon System Designator Code (WSDC)

"7Y" is the WSDC assigned to the crane.

(3) Distribution Code.

Code "F" will be cited in Card Column 54 for all CONUS only requisitions. All OCONUS will cite the applicable code as cited in AR 725-50.

c. MILSTRIP Requisition Card Column Entries.

- (1) NSN Requisitions: See Appendix 1-B for Card Column entries.
- (2) Non-NSN Requisitions: See Appendix i-A for Card Column entries.

d. Requisitioning and Flow of Requisitions.

- (1) NSN Requisitions: See paragraph 3-4 , titled "Requisitioning of Repair Parts.
- (2) Non-NSN Requisitions: See paragraph 3-4 , titled "Requisitioning of Repair Parts.

**1-3. MAINTENANCE FORMS AND RECORDS**

DA Forms and Procedures used for the equipment maintenance will be those prescribed in Section II, paragraph 2-12,

## APPENDIX 1-A

Card Column	Description of Data	Mandatory Entry for CCE
1-3	Document Identifier Code	A & B - CONUS A & 2 - Overseas
4-6	Routing Identifier Code	
7	Media/Status Code	
8-22	FSCM and Part Number	
23-24	Unit of Issue	
25-29	Quantity	
30-43	Document Number	
44	Demand Code	
45-50	Supplementary Address	
51	Signal Code	
52-53	Fund Code	
54-56	Distribution Code CC-54	"F" for CONUS; see AR 725-50 for OCONUS
CC-55-56	*Weapons System Code	
57-59	Project Code	
60-61	Priority Code	
62-64	Required Delivery Date	* Will not be assigned.
65-66	Advice Code	
67-69	Blank	
70	Identification code applicable to entry in cc 71-80. A - Technical order or Technical Manual. B - End Item Identification C - Noun Description D - Drawing or Specification No.	
71-80	Reference Identification	Identification of reference specified in cc 70.

Sample Format - MILSTRIP requisition for CCE (Non-NSN)

TAO72414

### APPENDIX 1-B

DD FORM 1348m 1 MAR 74 EDITION OF 1 APR 71 MAY BE USED

REQ. IDENT.	PRT. IDENT.	F.S.C.	STOCK NUMBER	UNIT	QUANTITY	REQUISITION DATE	SERIAL	SUPPLEMENTARY ADDRESS	FUND	DISTRIB. PROJ.	PRIORITY	VARIABLE DATA ELEMENTS
DOCUMENT IDENTIFIER	ROUTING IDENTIFIER	F.S.C.	STOCK NUMBER	UNIT	QUANTITY	REQUISITION DATE	SERIAL	SUPPLEMENTARY ADDRESS	FUND	DISTRIB. PROJ.	PRIORITY	VARIABLE DATA ELEMENTS
ENTIRE DATA												
DOCUMENT NUMBER												
DOCUMENT IDENTIFIER												
ROUTING IDENTIFIER												
STOCK NUMBER												
UNIT												
QUANTITY												
REQUISITION DATE												
SERIAL												
SUPPLEMENTARY ADDRESS												
FUND												
DISTRIB. PROJ.												
PRIORITY												
VARIABLE DATA ELEMENTS												
DOCUMENT IDENTIFIER CODE												
REMARKS												
ADVISE												
RI - TO												
FUND												
DISTRIB. PROJ.												
PRIORITY												
VARIABLE DATA ELEMENTS												
DOCUMENT IDENTIFIER CODE												

<u>Card Column</u>	<u>Description of Data</u>	<u>Mandatory Entry for CCE</u>
1-3	Document Identifier Code	A Q, A - CONUS A Q, 1- Overseas
4-6	Routing Identifier Code	
7	Media/Status Code	
8-22	NSN	
23-24	Unit of Issue	
25-29	Quantity	
30-43	Document Number	
44	Demand Code	
45-50	Supplementary Address	
51	Signal Code	
52-53	Fund Code	
54-56	Distribution Code CC-54	"F" for CONUS; see AR 725-50 for OCONUS * Weapons System Code
	CC-55-56	
57-59	Project Code	
60-61	Priority Code	
62-64	Required Delivery Date	* Will not be assigned.
65-66	Advice Code	

Sample Format - MILSTRIP requisition for CCE (NSN)

TAO72415

**SECTION II**  
**MAINTENANCE SUPPORT PLANNING DATA**

**2-1. PURPOSE**

The crane is a truck mounted, hydraulic operating crane of 25-ton capacity used for the construction tasks of lifting, pile-driving and clamshell operation.

**2-2. DESCRIPTION**

Part 3 covers a commercial diesel-engine-driven, 8 x 4, truck mounted, full revolving hydraulic operating crane of 25-ton capacity. The crane is an "off-the-shelf" item of the latest model of the standard product used in the civilian construction industry. The crane consists essentially of eight wheels, four rear wheel drive, four front wheel steer, pneumatic-tired, diesel-engine-powered carrier. The carrier is equipped with a full continuous 3600 revolving superstructure with cab, and a full power hydraulic telescoping boom. The boom is capable of extending to a radius of 72 feet when in a horizontal position. The crane carrier is equipped with a main and auxiliary transmission, clutch and selective gears that provide 20 forward and 4 reverse speeds. The crane engine has a 12 volt electrical system, and is equipped with a charging alternator with a rating of 35 amperes. The crane is the manufacturer's latest standard model which has been produced and marketed for a minimum period of one year and meets the requirements set forth in the item description. The category of maintenance for the crane will be in accordance with the Maintenance Allocation Chart (MAC). (See Appendix 2-A). Refer to paragraph 3-4 for requisitioning of repair parts and support. The intended uses are as follows:

a. Intended Use.

The crane is intended for use in a wide variety of construction and rehabilitation missions.

- (1) Roads
- (2) Airfields
- (3) Pipeline Systems
- (4) Structures and Utilities
- (5) Heliports
- (6) Railroads
- (7) Bridges
- (8) Port, Beach and Marine, POL Facilities

b. Construction Tasks.

- (1) Lifting
- (2) Pile-Driving
- (3) Clamshell

**2-3. Procurement Status:** The procurement contract number is DSA700-73-C-9003. is a multi-year contract for a total of 330 Cranes in FY72 and FY73.

**2-4. MOS Requirements:**

- a. Operator: Crane operator, MOS62F30.
- b. Organizational: Engineer equipment repairman MOS62B20.
- c. Direct/General Support: Engineer equipment repairman, MOS62B30 Special Electrical/Electronic Repairman MOS35E20.

**2-5. Logistics Assistance (AR 700-4):** US Army Tank-Automotive Materiel Readiness Command's field maintenance technicians stationed at CONUS and OCONUS installations are available to furnish on-site training and/or technical assistance. When training or technical assistance is required, contact the appropriate Logistics Assistance Office (LAO) listed in Appendix B, AR 700-4.

**2-6. Maintenance Concept:**

- a. Operator/Crew Maintenance: Operator and crew maintenance is limited to daily preventive maintenance services.
- b. Organizational Maintenance: Organizational maintenance consists of scheduled preventive maintenance services, minor repairs and adjustments.
- c. Direct Support Maintenance: Direct support maintenance consists of all the repairs required to restore an unserviceable end item of assembly to a serviceable condition.
- d. General Support Maintenance: General Support Maintenance exceeds the capability of Direct Support Maintenance.
- e. Depot Maintenance:
  - (1) Depot Maintenance will overhaul items of equipment, assemblies and components for return to supply stocks and in accordance with normal Army maintenance procedures.
  - (2) The Government may enter into an overhaul and/or repairs contract with crane manufacturer when determined to be more economical or feasible.

- (3) The Maintenance Expenditure Limit is depicted in TB 43-0002-28.
- (4) Mission essentiality: None
- (5) Maintenance Allocation Chart (MAC)

**2-7. Maintenance Allocation Chart (MAC):** See Appendix 2-A. Units may exceed their authorized scope and function in the MAC when approved by the Support Maintenance Commander.

**2-8. Modifications:** Modifications will be accomplished by the end item manufacturer after TARCOM approves the field campaign or modification plan.

See Appendix 2-B.

**2-9. Equipment Improvement Recommendations (EIR):** Equipment Improvement Recommendations will be submitted in accordance with TM 38-750.

**2-10. Shipment and Storage:** Refer to the Operating Instructions and Service Manual, and TB 740-97-2.

**2-11. Destruction to Prevent Enemy Use:** Refer to TM 750-244-3 for instructions governing destruction of equipment to prevent enemy use.

**2-12. Basic Issue Item List (BIL):** See Appendix 2-C.

**2-13. Special Tools and Equipment:** See Section III of Appendix 2-A.

**2-14. Maintenance and Operating Supplies:** See Appendix 2-D for a list of maintenance and operating supplies required for Initial operation.

**2-15. Maintenance Forms and Records:**

a. Operational Records: Operational records (DA Form 2400 and 2401) are optional any may be utilized at the discretion of the using organization.

b. Maintenance Records:

- (1) DA Form 2402, Exchange Tag.
- (2) DA Form 314, Preventive Maintenance Schedule and Record.
- (3) DA Form 2404, Equipment Inspection and Maintenance Worksheet.
- (4) DA Form 2405, Maintenance Request Register.
- (5) DA Form 2407, Maintenance Request.

c. Historical Records:

- (1) DA Form 2408, Equipment Logbook Assembly.
- (2) DA Form 2408-1, Equipment Daily and Monthly Log.
- (3) DA Form 2408-5, Equipment Modification Record.

- (4) DA Form 2408-9, Equipment Control Record.
- (5) DA Form 2408-10, Equipment Component Register.
- (6) DA Form 2408-14, Uncorrected Fault Record.

**2-16. WARRANTY**

a. The contractor warrants the supplies furnished under this contract as described on the warranty decal and cited on the warranties in the equipment manual.

b. Procedures.

(1) Selection of exhibits. When it has been determined that a component, part, or assembly of an end item under warranty is defective because of design deficiency or poor workmanship in production, the defective component, part of assembly will be identified as a warranty claim exhibit. Claim actions are initiated at organizational, direct and general support, and depot levels.

(2) Use of DA Form 2402. In warranty claim cases, organizational, direct support, general support, and depot maintenance activities will tag all warranty claim exhibits with a DA Form 2402. The DA Form 2402 will be used as an exchange tag to identify items being held for warranty claim exhibits. In each case, the tag will be marked "Warranty Exhibit." The exchange tag consists of four sections:

(a) Section 1 remains with the item (to assure identification) until the item is repaired and used. It identifies the tagged item as "Serviceable" after repair.

(b) Sections 2, 3, and 4 serve as receipts. Usually, section 4 is a receipt for the unit, section 3 the battalion level, and section 2 for support activities. (All sections are not always required.) When used as a receipt, the date and signature of the individual accepting the item will be entered on the reverse side of the section used.

(c) When an unserviceable item is immediately exchanged for a tagged serviceable item, the receipt portion of the card is not used.

c. Preparation.

- (1) The unserviceable part or assembly will be identified by making entries in DA Form 2402 blocks as follows:
  - (a) Block 1. Enter the support agency where the item is to be exchanged.
  - (b) Block 2. Enter calendar date the item was prepared for exchange.
  - (c) Blocks 3, 11 and 15. Enter unit or organization originating the exchange.



(d) Block 4. Enter national stock number, or manufacturer's part number when an NSN has not been assigned to the defective part or assembly with the priority designator (PD) assigned by unit or organization listed in block 3. Unit commander, or acting unit commander, will place his signature in the upper right margin of the form when PD 01 through n8 is used.

(e) Blocks 12, 16 and 20. Enter national stock number of the defective part or assembly.

(f) Blocks 5, 19 and Item. Noun nomenclature sections 1, 2, 3 and 4; e.g., carburetor generator, starter, etc.

(g) Block 6. Enter a "W" in the "EIR Exhibit" space.

(h) Blocks 8, 13, 17 and 21. Enter the nomenclature, and manufacturer (if applicable) of the end item from which the item was removed.

(i) Block 9. Model of the equipment from which the item was removed; e.g., M151A1, UHID, AN/GRC-46, if applicable.

(j) Blocks 10, 14, 18 and 22. Enter the end item serial number from which the item was removed.

(k) Date submitted (calendar) block on sections 2, 3 and 4. Enter date item is received for exchange.

(l) Block 23. Date of manufacture or last overhaul.

(m) Block 24. Name of manufacturer or overhaul activity.

(n) Block 25. Place "X" in the space which best identifies when failure was detected.

(o) Block 26. Place "X" in the space which best identifies first indication of trouble.

(p) Block 27. Utilizing the information on DA Form 24n4, describe briefly and clearly the failure; e.g., carburetor will not adjust for idle.

(2) If immediate exchange is not possible, the bottom portion of the tag is detached by the support unit and furnished to the customer as a receipt. Upon availability of a serviceable like item, the receipt tag is exchanged for the serviceable item.

#### **NOTE**

In those cases in which the support agency cannot provide a serviceable item to the supported organization within a time frame compatible with the priority designator (PD), the support agency will place a requirement on the supply system in accordance with local procedures.

(3) Block 7 will be completed by the individual making the repair.

(4) DA Form 2402 used to identify warranty claim exhibits are completed as described above, the preprinted control number of the applicable DA Form 2407 is entered in block 27.

(5) If applicable, serial number of the unserviceable DX item will be entered in block 27.

d. Disposition.

(1) When a part or component, to which DA Form 2402 has been attached, is installed on an item of equipment or disposed of, the form will be destroyed.

(2) Sections of this form, used as a receipt, will be destroyed after the exchange transactions are completed.

(3) When used to identify a warranty claim exhibit, section 1 of DA Form 2402 will remain attached to the exhibit until there is no further requirement.

e. Preparation of DA Form 2407.

(1) DA Form 2407 will be used to submit warranty claim action for end items. When components, parts or assemblies are identified as being defective and are covered by manufacturer's warranty; and to obtain reimbursement for maintenance man-hours expended in replacing the defective items. End items under warranty are identified by a decal plate. All warranty actions settled or unsettled will be reported to the national level. For warranties settled locally the DA Form 2407 will contain a statement in Block 35 "For information only."

(2) The organizational, direct and general support maintenance and depot activities will prepare the DA Form 2407 as follows:

- (a) Heading. Enter a "W" in the EIR space and control number in the space provided.
- (b) Block 1a. Enter the name of the organization submitting the report.
- (c) Block 1b. Enter the location of the unit initiating the request, units overseas enter APO only.
- (d) Block 1c. Enter the unit identification code of the unit identified in block 1a.
- (e) Block 2. Enter serial number of the end item.
- (f) Block 3. Enter the noun nomenclature of equipment for which the form was initiated.

- (g) Block 4. Leave blank.
- (h) Block 5. Enter the model designation of equipment for which the form was initiated. If the item has no model designation, leave blank.
- (i) Block 6. Enter the National Stock Number of equipment listed in block 3. When completing this form for bulk items having multiple NSN's, leave blank.
- (j) Block 7. Enter the symbol of the maintenance activity performing the maintenance. No entry shall be made in the "yes" or "no" blocks.
- (k) Block 8. Enter the appropriate utilization code.
- (l) Block 9. Place a 'V' or an "X" in the "yes" block if the item is a DA directed sampling item. For all other equipment, place a " " or an "X" in the "no" block.
- (m) Block 10. Enter the hour reading (rounded to the nearest hour) from the hour meter. If not applicable, leave blank.
- (n) Block 11. Enter the mileage reading (rounded to the nearest mile) from the odometer. If not applicable, leave blank.
- (o) Block 12.. Leave blank.
- (p) Block 13. Leave blank.
- (q) Block 14. Enter a 'V' or an "X" in the space provided to indicate when the failure was detected. Exception. Leave blank if no failure is involved, or DA directed sampling items organizational maintenance.
- (r) Block 15. Place a "K" or an "X" in the space provided that most accurately describes the condition at time of first indication of trouble. Exception. Leave blank if block 14 was left blank, or DA directed sampling items organizational maintenance.
- (s) Block 16. Enter "Warranty Claim Actions."
- (t) Block 20, column d. Enter noun identifying the part or assembly.
- (u) Block 20, column e. Enter serial number of the part or assembly.
- (v) Block 20, column g. Enter the number of man-hours required for the task of replacing the defective part. Use the appropriate TB time schedule guide, if available, otherwise record actual man-hours used.
- (w) Block 20, column h. Enter NSN of defective part, or manufacturer's part number when NSN has not been assigned.

- (x) Block 20, columns i, j and k. Self-explanatory.
- (y) Block 201. Self-explanatory.
- (z) Block 20m. Multiply the value of block 201 by \$6.00 and enter the product in block 20m.
- (aa) Block 20n. Self-explanatory.
- (bb) Block 23. Enter signature of the individual authorized to submit DA Form 2407.
- (cc) Block 30. Place check in space provided for "ROUTINE-"
- (dd) Block 31. Enter a " " or an "X" in space for "other" and state under "remarks" in block 35 "Replace Defective Part."
- (ee) Block 32. Enter organization submitting the report.
- (ff) Block 33. Enter National Stock Number of defective part or assembly.
- (gg) Block 34. Enter nomenclature of defective part or assembly.
- (hh) Block 35. Enter the complete telephone number (autovon/ commercial with area code) of the originator on the first line of this block. State in clear terms all factors which contributed to the failure, include date the part failed; the contract number and date warranty period began; USA registration number of the end item, if applicable; complete accounting classification for unit to be credited for cost of labor expended; the MILSTRIP document number and supplementary address of the unit which is to receive disposition instructions and notice of favorable claim actions.

(3) Support activities. Maintenance activities in support of organizational maintenance are the responsible points of contact between the originator of warranty claim actions and the national maintenance point, which serves as the DA representatives with the contractor in warranty matters.

#### **NOTE**

In certain instances, the originating organization and the support activity are one and the same.

As such, support and depot maintenance activities will establish the following procedures for processing and disposing of warranty claim actions.

(a) Non-direct exchange (DX) claim items. When the defective component part or assembly is not a DX item, the originating organization will prepare and submit a completed DA Form 2402 (with exhibit) and DA Form 2407 (as prescribed herein) to the support maintenance activity. The support maintenance activity will process DA Form 2407 as follows:

1. Copy #1. Destroy.
2. Copies #2 and #5. Forward to appropriate NMP for disposition instructions.
3. Copy #3. Retain at support maintenance level for a period of 180 days (including exhibit, and DA Form 2402) unless disposition instructions are not received, follow-up will be made with the responsible NMP.
4. Copy #4. Receipted copy #4 is authorization for immediate replacement action by the claim originator through supply channels. The copy #4 will be retained for a period not to exceed 180 days, or until notice has been received that the claim has been honored.

(b) Direct Exchange (DX) claim items. When the defective component, part or assembly is a DX item, the organization initiating the claim action will follow the procedures prescribed for non-DX items, except as follows:

1. The activity operating the DX facility will initiate replacement action for supported organizations using copy #4, as described above, to obtain replacement action.
2. Normal DX replacement actions will be made by the DX facility for like serviceable items in stock, pending completion of claim action.

(c) Final processing of approved claims. Support or depot maintenance activities are responsible to assure expeditious handling of all warranty claim actions. This includes processing of approved claims back to the originator whose supplementary address and MILSTRIP document number appear in block 35, DA Form 2407; and the processing of funds reimbursed for costs of labor required to replace defective components, parts or assemblies.

**3-2-9 / (3-2-10 blank).**

## APPENDIX 2-A

## MAINTENANCE ALLOCATION CHART

## Section I. INTRODUCTION

**2-A-1. General**

a. This section provides a general explanation of all maintenance and repair functions authorized at various maintenance categories.

b. The Maintenance Allocation Chart (MAC) in section II designates overall authority and responsibility for the performance of maintenance functions on the identified end item or component. The application of the maintenance functions to the end item or component will be consistent with the capacities and capabilities of the designated maintenance categories.

c. Section III lists the tools and test equipment (both special tools and common tool sets) required for each maintenance function as referenced from section II.

d. Section IV contains supplemental instructions and explanatory notes for a particular maintenance function.

**2-A-2. Maintenance Functions.** Maintenance functions will be limited to and defined as follows:

a. *Inspect.* To determine the serviceability of an item by comparing its physical, mechanical, and/or electrical characteristics with established standards through examination (e.g., by sight, sound, or feel).

b. *Test.* To verify serviceability by measuring the mechanical, pneumatic, hydraulic, or electrical characteristics of an item and comparing those characteristics with prescribed standards.

c. *Service.* Operations required periodically to keep an item in proper operating condition, i.e., to clean (including decontaminate, when required), to preserve, to drain, to paint, or to replenish fuel, lubricants, chemical fluids, or gases.

d. *Adjust.* To maintain or regulate, within prescribed limits, by bringing into proper or exact position, or by setting the operating characteristics to specified parameters.

e. *Aline.* To adjust specified variable elements of an item to bring about optimum or desired performance.

f. *Calibrate.* To determine and cause corrections to be made or to be adjusted on instruments or test, measuring, and diagnostic equipments used in precision measurement. Consists of comparisons of two instruments, one of which is a certified standard of known accuracy, to detect and adjust any discrepancy in the accuracy of the instrument being compared.

g. *Remove/Install.* To remove and install the same item when required to perform service or other maintenance functions. Install may be the act of emplacing, seating, or fixing into position a space, repair part, or module (component or assembly) in a manner to allow the proper functioning of an equipment or system.

h. *Replace.* To remove an unserviceable item and install a serviceable counterpart in its place. "Replace" is authorized by the MAC and is shown as the third position of the SMR code.

i. *Repair.* The application of maintenance service<sup>1</sup>, including fault location/troubleshooting<sup>2</sup>, removal/installation, disassembly/assembly<sup>3</sup> procedures, and maintenance actions<sup>4</sup> to identify troubles and restore serviceability to an item by correcting specific damage, fault, malfunction, or failure in a part, subassembly, module (component or assembly), end item, or system.

j. *Overhaul.* That maintenance effort (service/action) prescribed to restore an item to a completely serviceable/operational condition as required by maintenance standards in appropriate technical publication (i.e., DMWR). Overhaul is normally the highest degree of maintenance performed by the Army. Overhaul does not normally return an item to like-new condition.

<sup>1</sup> Service inspect, test, service, adjust, aline, calibrate, and/or replace.

<sup>2</sup> Fault locating/troubleshooting The process of investigating and detecting the cause of equipment malfunctioning; the act of isolating a fault within a system or unit under test (UUT).

<sup>3</sup> Disassembly/assembly encompasses the step-by-step taking apart (or breakdown) of a spare/functional group coded item to the level of its least componency identified as maintenance significant (i.e., assigned an SMR code) for the category of maintenance under consideration.

<sup>4</sup> Action - welding, grinding, riveting, straightening, facing, remachining, and/or resurfacing.

*k. Rebuild.* Consists of those services/actions necessary for the restoration of unserviceable equipment to a like-new condition in accordance with original manufacturing standards. Rebuild is the highest degree of materiel maintenance applied to Army equipment. The rebuild operation includes the act of returning to zero those age measurements (hours/miles, etc.) considered in classifying Army equipment/components.

### **2-A-3. Explanation of Columns in the MAC, Section II**

*a. Column 1, Group Number.* Column 1 lists functional group code numbers, the purpose of which is to identify maintenance significant components, assemblies, subassemblies, and modules with the next higher assembly. End item group number shall be "00".

*b. Column 2, Component/Assembly.* Column 2 contains the names of components, assemblies, subassemblies, and modules for which maintenance is authorized.

*c. Column 3, Maintenance Function.* Column 3 lists the function to be performed on the item listed in Column 2. (For detailed explanation of these functions, see paragraph 2-A-2).

*d. Column 4, Maintenance Category.* This column specifies the average total man-hours required to do the job. For example, if it takes two people five hours to complete the job, the figure would be ten. This figure represents the time required to perform the job at the lowest indicated category of maintenance and restore the item to a serviceable condition. It includes disassembly, troubleshooting, quality assurance and assembly. The symbol designations for the various maintenance categories are as follows:

- C - Operator or Crew
- O - Organizational Maintenance
- F - Direct Support Maintenance
- H - General Support Maintenance
- D - Depot Maintenance

*e. Column 5, Tools and Equipment.* Column 5 specifies by code, those common tool sets (not individual tools) and special tools, TMDE, and support equipment required to perform the designated function.

*f. Column 6, Remarks.* This column shall, when applicable, contain a letter code, in alphabetical order, which shall be keyed to the remarks contained in Section IV.

### **2-A-4. Explanation of Columns in Tool and Test Equipment Requirements, Section III**

*a. Column 1, Reference Code.* The tool and test equipment reference code correlates with a code used in the MAC, Section II, Column 5.

*b. Column 2, Maintenance Category.* The lowest category of maintenance authorized to use the tool or test equipment.

*c. Column 3, Nomenclature.* Name or identification of the tool or test equipment.

*d. Column 4, National Stock Number.* The National stock number of the tool or test equipment.

*e. Column 5, Tool Number.* The manufacturer's part number.

### **2-A-5. Explanation of Columns in Remarks, Section IV**

*a. Column 1, Reference Code.* The code recorded in column 6, Section II.

*b. Column 2, Remarks.* This column lists information pertinent to the maintenance function being performed as indicated in the MAC, Section II.

**Section II. MAINTENANCE ALLOCATION CHART**

(1) GROUP NUMBER	(2) COMPONENT ASSEMBLY	(3) MAINTENANCE FUNCTION	(4) MAINTENANCE LEVEL					(5) TOOLS AND EQUIPMENT	(6) REMARKS
			C	O	F	H	D		
01	ENGINE								
0100	Engine Assembly	Inspect Test Service Replace Repair Overhaul		0.1  0.2	2.0  16.0 2.0		60.0		
0101	Crankcase, Block, Cylinder Head Engine Block	Inspect Replace Repair Overhaul				0.5 20.0 1.0 30.0			
	Cylinder Head	Inspect Replace Repair Overhaul			6.0	1.0 2.0 12.0			
0102	Crankshaft	Inspect Replace Repair				1.0 10.0 6.0			
	Bearings, Main	Inspect Replace				1.0 10.0			
	Pulley	Inspect Replace		0.2					
0103	Flywheel Assembly	Inspect Replace Repair			4.0 0.2 4.0		1.5		
	Flywheel Housing	Inspect Replace Repair				0.1 4.0 1.0			
	Gear, Spur	Inspect Replace				0.1 1.5			
0104	Pistons, Connecting Rods	Inspect Replace Repair				1.0 8.0 2.0			
	Bearings and Rings	Inspect Replace Repair				1.0 8.0 8.0			
0105	Valves, Camshafts and Timing System Valves, Springs and Guides Rocker Arms	Inspect Replace Inspect Replace Repair		0.5	0.5 6.0 1.0	4.0			
	Covers and Gasket, Rocker Arm and Side Covers	Inspect Replace Repair		0.2 1.0 1.0					
	Camshaft, Bearings, Timing Gears	Inspect Replace Repair			1.0	10.0 2.0			



**Section II. MAINTENANCE ALLOCATION CHART**

(1) GROUP NUMBER	(2) COMPONENT ASSEMBLY	(3) MAINTENANCE FUNCTION	(4) MAINTENANCE LEVEL					(5) TOOLS AND EQUIPMENT	(6) REMARKS
			C	O	F	H	D		
01 0106	ENGINE - CONTINUED Engine Lubrication System Dipstick  Filter, Oil  Housing, Oil Cooler  Pan, Oil  Pump, Oil  Element, Oil Filter	Inspect	0.1						
		Replace		0.1					
		Service		1.0					
		Replace		1.0					
		Repair		0.5					
		Inspect		0.1					
		Test			2.0				
		Replace			2.0				
		Repair				4.0			
		Inspect		0.2					
		Replace			1.0				
		Inspect			0.2				
		Replace			4.0				
		Repair				2.0			
		Service		0.2					
Replace	0.5								
0108	Manifolds	Inspect			0.2				
		Replace			2.0				
0121	Compressor, Air	Inspect		0.2					
		Replace		3.0					
		Repair			3.0				
	Shafts and Adapter	Inspect			0.2				
		Replace			4.0				
		Replace			4.0				
02 0200	CLUTCH Clutch Assembly	Replace			4.0				
		Repair			4.0				
0202	Clutch Release Mechanism Pedal, Linkage	Inspect		0.2					
		Adjust		0.5					
		Replace			1.0				
	Yoke and Bearing	Inspect			4.0				
		Replace			2.0				
		Replace			2.0				
0207	Hydraulic Clutch System Cylinders, Hydraulic, Master	Replace			2.0				
		Repair			1.0				
03 0301	FUEL SYSTEM Carburetor, Fuel Injector Nozzle Assembly, Fuel Injector	Test			2.0				
		Adjust			0.5				
		Replace			3.0				
		Repair				1.0			
		Repair				1.0			

**Section II. MAINTENANCE ALLOCATION CHART**

(1) GROUP NUMBER	(2) COMPONENT ASSEMBLY	(3) MAINTENANCE FUNCTION	(4) MAINTENANCE LEVEL					(5) TOOLS AND EQUIPMENT	(6) REMARKS
			C	O	F	H	D		
03	FUEL SYSTEM-- CONTINUED								
0302	Fuel Pumps Gearshaft and Gear Assembly	Test Replace Repair			1.0 1.0		2.0		
0304	Air Cleaner Filter, Air  Housing, Air Cleaner	Service Replace Service Replace Repair	0.5  0.2	1.0  0.5 1.0					
0305	Supercharger, Blower, Turbocharger  Housing Assembly, Air Inlet	Inspect Replace Repair  Replace		0.5	4.0 4.0		2.0		
0306	Tanks, Lines, Fittings, Headers Tank, Fuel  Lines and Fittings	Inspect Service Replace Repair  Inspect Replace		0.1 0.2	1.0 1.0				
0308	Engine Speed Governor and Controls Housing, Governor  Engine Speed Governor	Replace Repair  Inspect Adjust Replace Repair	0.1	1.0			1.0 2.0		
0309	Fuel Filters Filter, Element, Fluid	Service Replace		0.2 1.0					
0311	Engine Starting Aids Hardware, Starting Aid	Inspect Replace		0.1 0.5					
0312	Accelerator, Throttle or Choke Controls Pedal and Valve	Inspect Replace Repair		0.1 0.5 0.5			4.0		

Change 3 3-2-15

**Section II. MAINTENANCE ALLOCATION CHART**

(1) GROUP NUMBER	(2) COMPONENT ASSEMBLY	(3) MAINTENANCE FUNCTION	(4) MAINTENANCE LEVEL					(5) TOOLS AND EQUIPMENT	(6) REMARKS
			C	O	F	H	D		
04	EXHAUST SYSTEM								
0401	Muffler and Pipes Exhaust Pipes and Muffler	Inspect Replace Repair	0.1	2.0 2.0					
05	COOLING SYSTEM								
0501	Radiator, Evaporative Cooler, or Heat Exchanger Radiator Assembly	Inspect Test Service Replace Repair	0.2 0.1		0.5 2.5 2.0				
0502	Cowling, Deflectors, Air Ducts, Shrouds, Etc. Shrouds, Radiator	Inspect Replace	0.1		0.2				
0503	Water Manifold, Headers, Thermostats and Housing Gasket Thermostat, Housing and Housing Gasket Hoses, Radiator	Inspect Replace Inspect Replace	0.2	0.2 1.0					
0504	Water Pump	Inspect Replace Inspect Replace Repair	0.2	2.0 0.5 1.5	2.0				
0505	Fan Assembly Bearings, Shaft and Pulley Blade, Fan	Service Replace Inspect Replace		0.1 0.1	2.5 0.5				
06	Belt, Fan/Water Pump Drive	Inspect Replace	0.1	0.5					
0601	ELECTRICAL SYSTEM Alternator	Test Replace Repair		0.2 1.0	3.0				
	Alternator Drive Belts	Inspect Adjust Replace	0.1	0.2 0.5					
0602	Regulator, Voltage	Test Adjust Replace Repair		0.3 0.2 0.5	2.0				

**Section II. MAINTENANCE ALLOCATION CHART**

(1) GROUP NUMBER	(2) COMPONENT ASSEMBLY	(3) MAINTENANCE FUNCTION	(4) MAINTENANCE LEVEL					(5) TOOLS AND EQUIPMENT	(6) REMARKS
			C	O	F	H	D		
06	ELECTRICAL SYSTEM- CONTINUED								
0603	Starting Motor	Test Replace		0.2 2.0					
	Brushes	Replace			2.0				
	Solenoid	Test Replace		0.2 1.0	0.5				
0606	Engine Safety Controls Switches and Solenoid, Engine Shut Off	Test Replace		0.2 0.4					
0607	Instrument or Engine Control Panel								
	Switches and Gages and Meters	Inspect Replace	0.1	0.5					
	Lights and Lamps	Inspect Test Replace	0.1	0.2 0.2					
	Panel and Wiring	Inspect Replace		0.2	8.0				
	Control Box, Outtrigger	Repair Replace Repair		0.3	1.0 2.0				
0608	Fuses	Test Replace		0.2 0.5					
0609	Lights	Inspect Test Replace	0.1	0.2 0.5					
0610	Sending Units and Warning Switches								
	Transmitters and Switches	Inspect Replace		0.2 0.5					
	Back-Up Warning and Indicator Box	Replace Repair		0.5 0.5					
0611	Horn, Siren Horn and Horn Button	Inspect Test Replace	0.1	0.1 1.0					
0612	Batteries, Storage	Inspect Test Service Replace	0.1	0.2 0.5	1.0				
	Cables, Battery	Inspect Service Replace	0.1	0.5 1.0					

Change 3 3-2-17

**Section II. MAINTENANCE ALLOCATION CHART**

(1) GROUP NUMBER	(2) COMPONENT ASSEMBLY	(3) MAINTENANCE FUNCTION	(4) MAINTENANCE LEVEL					(5) TOOLS AND EQUIPMENT	(6) REMARKS
			C	O	F	H	D		
06	ELECTRICAL SYSTEM - CONTINUED								
0612	Batteries, Storage - Continued Box, Battery	Inspect Service Replace	0.1 1.0	1.0					
0613	Chassis Wiring Harness	Replace Repair			2.0 0.5				
07	TRANSMISSION								
0700	Transmission Assembly Main Transmission	Inspect Service Replace Repair Overhaul		0.2 0.2	16.0	10.0 20.0			
	Auxiliary Transmission	Inspect Service Replace Repair Overhaul		0.2 0.2	10.0	14.0 18.0			
0701	Transmission Shafts Synchronizers, Shafts and Gears	Inspect Replace				0.5 18.0			
0704	Transmissions Top Cover Assembly Forks, Shifter Cover and Rods	Inspect Adjust Replace		0.5 1.0	4.0				
	Tower, Rod and Bracket	Inspect Adjust Replace Repair		0.5 1.0	4.0 2.0				
	Cover Assembly, Clutch	Inspect Service Adjust	0.2		0.5				
0705	Gear Shift, Vacuum Booster and Controls	Inspect Replace Repair		0.1	0.5 2.0				

Change 3 3-2-18

**Section II. MAINTENANCE ALLOCATION CHART**

(1) GROUP NUMBER	(2) COMPONENT ASSEMBLY	(3) MAINTENANCE FUNCTION	(4) MAINTENANCE LEVEL					(5) TOOLS AND EQUIPMENT	(6) REMARKS
			C	O	F	H	D		
09	PROPELLER, PROPELLER SHAFTS, UNIVERSAL JOINTS, COUPLER AND CLAMP ASSEMBLY								
0900	Propeller Shafts	Inspect Replace		0.2	1.5				
	Universal Joints	Inspect Service Replace	0.2	0.2 1.5					
10 1000	FRONT AXLE Front Axle Assembly	Inspect Service Replace		0.2 0.2	5.0				
11	REAR AXLE								
1100	Rear Axle Assembly	Inspect Service Replace		0.2 0.2	5.0				
1102	Differential	Inspect Replace Repair Overhaul				0.5 2.0 4.0 6.0			
	Shaft Assemblies	Replace Repair				1.0 1.0			
12 1202	BRAKES Service Brakes Brake Shoe Assemblies	Inspect Adjust Replace Repair		1.0 1.0	12.0 2.0				
1208	Air Brake System Hoses, Lines, Fittings	Inspect Replace		0.1 0.5					
	Chamber, Brakes	Inspect Adjust Replace Repair		0.1 4.0 0.5	0.6				
	Valves, Brake	Inspect Replace Repair		0.1 0.8	0.8				
	Reservoir, Air	Inspect Service Replace	0.1 0.1	2.0					

Change 3 3-2-19

**Section II. MAINTENANCE ALLOCATION CHART**

(1) GROUP NUMBER	(2) COMPONENT ASSEMBLY	(3) MAINTENANCE FUNCTION	(4) MAINTENANCE LEVEL					(5) TOOLS AND EQUIPMENT	(6) REMARKS
			C	O	F	H	D		
13	WHEELS AND TRACKS								
1311	Wheel Assembly Hub and Drum Assemblies	Inspect Replace Repair		0.1	0.5 4.0				
1313	Tires, Tubes, Tire Chains Tires	Inspect Service Replace Repair	0.1	0.2 4.0 2.0					
14	STEERING								
1401	Mechanical Steering Gear Assembly Column, Steering  Tie Rod Assembly  Steering Wheel	Replace Repair Inspect Adjust Replace Inspect Replace	0.1		8.0 3.0 1.0 2.0				
1407	Power Steering Gear Assembly	Inspect Service Replace Repair	0.1 0.2		1.0 1.0				
1410	Hydraulic Pump or Fluid Motor Assembly Pump, Power Steering	Inspect Test Service Replace Repair	0.1	0.2 0.1	0.5	1.0			
1411	Filter, Fluid Hoses, Lines, Fittings	Replace Inspect Replace	0.1	1.0 0.5		1.0			
1412	Hydraulic or Air Cylinders Cylinder, Steering	Inspect Test Replace Repair	0.2	0.2	1.0 1.5				
1414	Steering System Valves Steering Valve	Inspect Replace Repair		0.1	0.5 1.0				

Change 3 3-2-20

**Section II. MAINTENANCE ALLOCATION CHART**

(1) GROUP NUMBER	(2) COMPONENT ASSEMBLY	(3) MAINTENANCE FUNCTION	(4) MAINTENANCE LEVEL					(5) TOOLS AND EQUIPMENT	(6) REMARKS
			C	O	F	H	D		
15	FRAME, TOWING ATTACHMENT AND DRAWBAR								
1501	Superstructure Crane	Replace				16.0			
1502	Counterweight	Replace		2.0					
1503	Pintles and Towing Attachments	Inspect Replace Repair	0.2	0.2 0.2					
1504	Spare Wheel Carrier and Tire Lock	Inspect Replace Repair	0.2	1.0 0.5					
16	SPRINGS AND SHOCK ABSORBERS								
1601	Springs	Inspect Service Replace	0.2	0.2					
1605	Torque, Radius, and Stabilizer Rods Torque Arms	Inspect Service Replace		0.1 0.1					
18	BODY, CAB, HOOD AND HULL								
1801	Body, Cab and Hood Assemblies Cab Assembly	Inspect Replace Repair		0.5		16.0			
	Door Assembly, Cab	Inspect Replace Repair	0.1	0.5	5.0				
	Control Panel	Inspect Replace Repair		0.2	0.5 8.0 2.0				
1802	Outriggers, Fenders, Running Boards, Glass	Inspect Service Replace Repair	0.1 0.1		8.0	4.0			
	Float, Outrigger	Inspect Service Replace Repair	0.1	0.1	2.0 1.5				
		<b>Change 3 3-2-21</b>							



**Section II. MAINTENANCE ALLOCATION CHART**

(1) GROUP NUMBER	(2) COMPONENT ASSEMBLY	(3) MAINTENANCE FUNCTION	(4) MAINTENANCE LEVEL					(5) TOOLS AND EQUIPMENT	(6) REMARKS
			C	O	F	H	D		
18	BODY, CAB, HOOD AND HULL - CONTINUED								
1806	Upholstery, Seats and Carpets Seat Assemblies	Inspect Replace Repair	0.1	1.0	1.0				
20	HOIST, WINCH, CAPSTAN, WINDLASS, POWER CONTROL UNIT, AND POWER TAKE-OFF								
2001	Hoist, Capstan, Windlass, Crane or Winch Assembly Winch Assembly	Replace Repair			8.0 4.0				
	Pump, Winch, Auxiliary	Replace Repair			6.0 4.0				
	Motor, Hydraulic Winch	Replace Repair			6.0 4.0				
	Valve, Main and Auxiliary Winch Control	Replace Repair			6.0 4.0				
22	BODY, CHASSIS, AND HULL ACCESSORY ITEMS								
2202	Accessory Items Mirror Assemblies	Inspect Replace Repair	0.1	0.5 0.5					
	Air Horn and Reflectors	Inspect Replace	0.1	0.5					
	Windshield Wiper Assembly	Inspect Replace Repair	0.1	0.5 2.0					
	Wiper Motor	Inspect Replace	0.1	0.5					
	Heater, Personnel	Inspect Replace Repair	0.2	4.0	2.0				
	Defroster	Inspect Replace	0.2	4.0					
2210	Data Plates and Instruction Holders Data Plates, Labels and Decals	Inspect Replace	0.1	0.2					

Change 3-2-22

Section II. MAINTENANCE ALLOCATION CHART

(1) GROUP NUMBER	(2) MAINTENANCE COMPONENT ASSEMBLY	(3) FUNCTION	(4) MAINTENANCE LEVEL TOOLS AND					(5) EQUIPMENT	(6) REMARKS
			C	O	F	H	D		
24	HYDRAULIC AND FLUID SYSTEMS								
2401	Pump and Motor Pump Drive Assembly	Inspect Test Replace Repair		0.1 0.2	4.0 3.0				
2402	Manifold and/or Control Valves Hydraulic Control Valves	Inspect Replace Repair		0.2	2.0 2.0				
2403	Hydraulic Controls and/or Manual Controls Lever Assemblies, Control, Hydraulic	Inspect Service Replace Repair		0.1 0.2	2.0 2.0				
2406	Strainers, Filters, Lines and Fittings, Etc. Hydraulic Lines and Fittings Filter, Oil Hydraulic	Inspect Replace Inspect Service Replace Repair		0.2 1.0 0.1 0.2 0.5 1.0					
2407	Hydraulic Cylinders	Inspect Service Replace Repair		0.2 0.2	4.0 6.0				
2408	Liquid Tanks or Reservoirs Reservoir Inspect	Service Replace Repair	0.2	0.1	2.0 2.0				
47	GAGES, WEIGHING AND MEASURING DEVICES								
4701	Instruments Speedometer and Cable	Test Replace		0.1 0.5					
4702	Gages, Mountings, Lines, and Fittings Indicators and Gages Replace	Inspect	0.1	1.0					
		<b>Change 3 3-2-23</b>							

Section II. MAINTENANCE ALLOCATION CHART

(1) GROUP NUMBER	(2) MAINTENANCE COMPONENT ASSEMBLY	(3) FUNCTION	(4) MAINTENANCE LEVEL TOOLS AND					(5) EQUIPMENT	(6) REMARKS
			C	O	F	H	D		
47	GAGES, WEIGHING AND MEASURING DEVICES - CONTINUED								
4702	Gages, Mountings, Lines, and Fittings - Continued Weigh Load Indicator	Inspect Repair Replace		0.2	2.0 3.0				
74	CRANES, SHOVELS, AND EARTH MOVING EQUIPMENT COMPONENTS								
7411	Crane Dragline or Clamshell Attachments Boom Assembly	Inspect Service Replace Repair		0.5 0.5	20.0	30.0			
	Hook Block	Inspect Service Replace Repair	0.1	0.1 0.5					
	Cables and Ropes	Inspect Replace Repair	0.3	2.0					
	Tagline	Inspect Service Replace Repair	0.1	0.2 1.0 6.0					
	Jib Mount	Inspect Replace Repair		0.1 0.5 2.0					
7413	Pile Drive Attachment Shaft and Plates Replace	Service			0.5 2.0				
7414	Base Deck Slewing Rim Brackets and Covers	Replace Inspect Replace		0.2	3.0	20.0			
7418	Transmission Assembly Transmission, Swing	Replace Repair				20.0 16.0			
		<b>Change 3 3-2-24</b>							

SECTION III. TOOL AND TEST EQUIPMENT REQUIREMENTS

(1) Tool or test equipment ref code	(2 ) Maintenance category	(3) Nomenclature	(4) National stock number	(5) Tool number
	O	Tool Kit Auto Maint: Org Maint Common #1	4910-00-754-0654	SC4910-95CLA74 (19204)
	O	Tool Kit Auto Mech: Light Weight	5180-00-177-7033	SC5180-90-CL-N26 (50980)
	O	Gage, Oil Pressure	4910-00-792-8304	3005456 (61465)
	O	Shop Eqp Auto Maint & Repair Org Suppl No 1 Less Power	4910-00-754-0653	SC4910-95CLA73 (19204)
	O	Shop Eqp Welding Set	4940-00-357-7268	SC3470-95CLA08 (19204)
	O	Tool Set, Veh Full Tracked Supp No 2	4940-00-754-0743	SC4940-95CLA08 (19204)
	O	Multimeter	6625-00-999-7465	SCDL551651 (80063)
	F	Shop Equip Contact Maint Truck Mounted	4940-00-294-9518	MILS45855 (81349)
	F	Shop Equip Gen Purp Repair Semitrlr Mtd	4940-00-287-4894	MILS45538 (81349)
	F	Shop Equip Org Repair Light Truck Mtd	4940-00-294-9516	MILS45537 (81349)
	F	Tool Kit Automotive Fuel and Elec Sys Repair	5180-00-754-0655	SC4910-95CLA50 (19204)
	F	Tool Kit Auto Maint: Org Maint Common #2	4910-00-754-0650	SC4910-95CLA72 (19204)
	F	Tool Kit Master Mech: Equip Maint & Repair	5180-00-699-5273	SC5180-90-CL-N05 (50980)
	F	Wrench Set Socket: 3/4" Drive Hex Type	5130-00-351-5135	A-A-399A (58536)
	F	Wrench Torque: 3/4" Drive 100 - 500 Lb Capacity	5120-00-542-5577	6017F (47805)
	F	Shop Eqp Fuel & Elec Sys Engine	4940-00-754-0714	SC4910-95CLAOI (19204)
	F	Shop Set Fuel & Elec Sys Supp No 2	4940-00-390-7775	SC4910-95CLA65 (19204)
	F	Test Set Dsl ljn	4910-00-317-8265	5910359 (19204)
	F	Shop Eqp Machine Shop Trk Mtd	3740-00-754-0708	SC3470-95CLA02 (19204)
<b>Change 3 3-2-25</b>				

**SECTION III. TOOL AND TEST EQUIPMENT REQUIREMENTS**

(1) Tool or test equipment ref code	(2 ) Maintenance category	(3)  Nomenclature	(4)  National stock number	(5)  Tool number
	F	Tool Kit Machinist	5280-00-511-1950	SC5280-95CLA02 (19204)
	F	Tool Kit Body and Fender Repair	5180-00-754-0643	SC5180-90CLN34 (50980)

**Section IV. REMARKS**

(1) Reference code	(2)  Remarks
	Not Applicable

**Change 3 3-2-26**

APPENDIX 2-B

CCE MANUFACTURER FIELD CAMPAIGNS AND MODIFICATION PROCEDURES

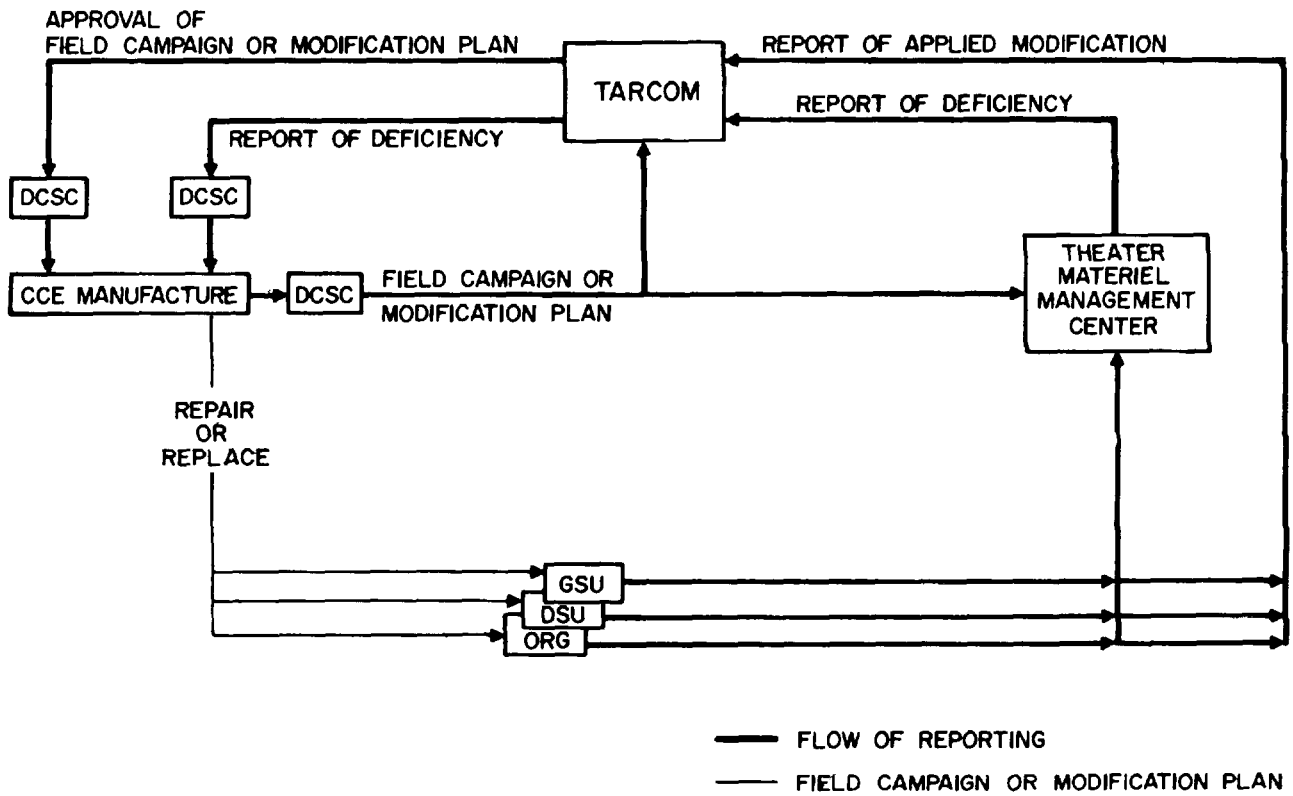

TA072413

**APPENDIX 2-C  
BASIC ISSUE ITEM LIST AND ITEMS  
TROOP INSTALLED OR AUTHORIZED**

**Section I. INTRODUCTION**

1. Scope

This appendix lists basic issue items, items troop installed or authorized which accompany the CCE Crane, and required by the crew/operator for operation, installation, or operator's maintenance.

2. General

This basic issue items, items troop installed or authorized list is divided into the following sections:

a. Basic Issue Items List - Section II. A list, in alphabetical sequence, of items which are furnished with and which must be turned in with the end item.

b. Items Troop Installed or Authorized List - Section III. A list, in alphabetical sequence of items which at the discretion of the unit commander may accompany the end item, but are NOT subject to be turned in with the end item.

3. Explanation of Columns

The following provides an explanation of columns in the tabular list of Basic Issue Items List, Section II, and Items Troop Installed or Authorized, Section III.

a. Source, Maintenance, and Recoverability Code(s) (SMR):

(1) Source Code, indicates the source for the listed item. Source codes are:

Code	Explanation
P	Repair parts, special tools and test equipment supplied from GSA/DSA or Army Supply System and authorized for use at indicated maintenance levels.
P2	Repair parts, special tools and test equipment which are procured and stocked for insurance purposes because the combat or military essentiality of the end item dictates that a minimum quantity be available in the supply system.

(2) Maintenance code, indicates the lowest level of maintenance authorized to install the listed item. The maintenance level code is:

<b>Code</b>	<b>Explanation</b>
-------------	--------------------

Crew/Operator

b. National Stock Number. This column indicates the National stock number assigned to the item and will be used for requisitioning purposes.

c. Description. This column indicates the National item name and any additional description of the item required.

d. Unit of Measure (U/M). A 2 character alphabetic abbreviation indicating the amount or quantity of the item upon which the allowances are based, e.g., ft, ea, pr, etc.

e. Quantity Furnished With Equipment (BIIL only). This column indicates the quantity of an item furnished with the equipment.

f. Quantity Authorized (Items Troop Installed or Authorized Only).

This column indicates the quantity of the item authorized to be used with the equipment.

g. Illustration (BIIL only). This column is divided as follows:

(1) Figure Number. Indicates the figure number of the illustration in which the item is shown.

(2) Item Number. Indicates the callout number used to reference the item in the illustration.

**NOTE**

**Paragraphs 4 and 5 to be used if applicable.**

4. Special Information.

Identification of the usable on codes included in column 3 of this publication are:

Code	Used On
None	None



(1) SMR CODE	(2) NATIONAL STOCK NUMBER	(3) DESCRIPTION	(4) UNIT OF ISSUE UNIT	(5) QTY INC IN UNIT PACK	(6) QTY INC INI EQUIP	(7) QTY FURN WITH	(8) QTY AUTH	(9) ILLUSTRATION	
								(a) FIG NO	(b) ITEM NO
	NONE FOR THE CRANE	3-2-37							

(1) SMR CODE	(2) NATIONAL STOCK NUMBER	(3) DESCRIPTION		(4) UNIT OF MEAS	(5) QUANTITY AUTHOR.			
		REF NO. & MFG CODE	USABLE ON CODE					
		NOTE: The following are overpacked with the crane.						
PC			Adapter: grease gun extension 21Z682 (27315)	EA		1		
PC	7520-00-559-9618		Case, Cotton Duck: MIL-B-11743 (81349)	EA		1		
PC			Gun, Grease: 21Z2 (27315)	EA		1		
PC			Handle: sheel nut wrench 21Z111 (27315)	EA		1		
PC			Hose assembly: grease gun 44Z186 (27315)	EA		1		
PC	7510-00-889-3494		Log Book Binder: MIL-B-43064	EA		1		
PC			Wrench Wheel Nut: 21Z33 (27315)	EA		1		
		NOTE: The following items are authorized but not issued with the crane. Requisition if required.						
PC	4210-00-889-2221		Extinguisher, Fire, Dry Chemical:	EA		1		
PC	5120-00-251-1102		Handle: wheel wrench, 3/4 in, dia 20 in long	EA		1		
		<b>3-2-38</b>						

APPENDIX 2-D

MAINTENANCE AND OPERATING SUPPLIES					
(1) COMPONENT APPLICATION	(2) NATIONAL STOCK NUMBER	(3) DESCRIPTION	(4) QUANTITY REQUIRED F/INITIAL OPERATION	(5) QUANTITY REQUIRED F/8 HRS OPERATION	(6) REMARKS
ENGINE		No. 2-D Diesel Fuel		55 Gallons	
COOLANT		50% Ethylene Glycol. 50% Water	40 Qts.		
ENGINE	9150-00-188-9858	ENGINE OIL MIL-L-2104C OE/HDO 30 - 5 Gallons	18-1/2 Qts.		
	9150-00-242-7603	MIL-L-10295 OES - 5 Gallons			
TRANSMISSION, MAIN	9150-00-754-2635	GEAR OIL MIL-L-2105 GO-90 - 1 Qt.	17 Pints		
	9150-00-905-9100	MIL-L-2105 GO-80 - 1 Qt.			
	9150-00-261-7904	MIL-L-10324 GOS - 1 Qt.			
TRANSMISSION, AUXILIARY	9150-00-754-2635	GEAR OIL MIL-L-2105 GO-90 - 1 Qt. MIL-L-2105 GO-80 - 1 Qt. MIL-L-10324 GOS - 1 Qt.	12 Pints		
		<b>3-2-39</b>			

<b>MAINTENANCE AND OPERATING SUPPLIES</b>					
(1) COMPONENT APPLICATION	(2) NATIONAL STOCK NUMBER	(3) DESCRIPTION	(4) QUANTITY REQUIRED F/INITIAL OPERATION	(5) QUANTITY REQUIRED F/8 HRS OPERATION	(6) REMARKS
FRONT REAR AXLE	9150-00-754-2635	GEAR OIL MIL-L-2105 GO-90 - 1 Qt.	32 Pints		
	9150-00-905-9500	MIL-L-2105 GO-80 - 1 Qt.			
	9150-00-242-7603	MIL-L-10295 OES - 5 Gallons			
REAR REAR AXLE	9150-00-754-2635	GEAR OIL MIL-L-2105 GO-90 - 1 Qt.	28 Pints		
	9150-00-905-9500	MIL-L-10295 GO-80 - 1 Qt.			
	9150-00-242-7603	MIL-L-10295 OES - 5 Gallons			
STEERING GEAR	9150-00-265-9425	HYDRAULIC OIL MIL-L-2104 OE/HDO 10 - 1 Qt.	2-1/2 Qts.		
	9150-00-242-7603	MIL-L-10295 OES - 5 Gallons			
	9150-00-186-6682	MIL-L-46152 LUBE OIL - 1 Qt.			
	9150-00-985-7231	MIL-L-46152 2075 TH - 1 Qt.			
	9150-00-966-8830	MIL-H-46001B, Type 1 HYD FLUID - 5 Gallons			

<b>MAINTENANCE AND OPERATING SUPPLIES</b>					
(1) <b>COMPONENT APPLICATION</b>	(2) <b>NATIONAL STOCK NUMBER</b>	(3) <b>DESCRIPTION</b>	(4) <b>QUANTITY REQUIRED F/INITIAL OPERATION</b>	(5) <b>QUANTITY REQUIRED F/8 HRS OPERATION</b>	(6) <b>REMARKS</b>
HYDRAULIC SYSTEM	HYDRAULIC OIL 9150-00-265-9429  9150-00-242-7603  9150-00-985-7233  9150-00-966-8831	200 Gallons MIL-L-2104 OE/HDO 10 - 55 Gallons MIL-L-10295 OES - 5 Gallons MIL-L-17672B 2075 TH - 55 Gallons MIL-H-46001B, Type 1 HYD FLUID - 55 Gallons  <p style="text-align: center;"><b>3-2-41/(3-2-42(blank))</b></p>			

**APPENDIX 2-E****PREVENTIVE MAINTENANCE****CHECKS AND SERVICES (CRANE)****2-E-1. General**

Preventive maintenance is detecting/correcting problems before they happen, or fixing little problems before they become big problems. Table 2-E-1 contains a list of preventive maintenance checks and services to be performed by operator/crew. Table 2-E-2 contains preventive maintenance checks and services to be performed by organizational maintenance personnel. Attention to these checks and services will increase the useful life of the equipment, but every possible problem cannot be covered in the PMCS. Be alert for anything that might cause a problem.

**2-E-2. Maintenance Forms and Records**

Every mission begins and ends with the paperwork. There isn't much of it, but you have to keep it up. The forms and records you fill out have several uses. They are a permanent record of the services, repairs, and modifications made on your equipment. They are reports to maintenance people and to your commander. They are also a checklist for you when you want to know what is wrong with the equipment after its last use, and whether those faults have been fixed. For the information you need on forms and records, see TM 38-750.

**2-E-3. Preventive Maintenance Checks and Services**

- a. Operator/crew shall perform the preventive maintenance checks and services shown in Table 2-E-1.

- (1) Do your (B) Preventive Maintenance just before you operate the equipment. Pay attention to the Cautions and Warnings.

- (2) Do your (D) Preventive Maintenance during operation. During operation means to monitor the crane and its related components while it is actually being operated.

- (3) Do your (A) Preventive Maintenance right after operating the equipment. Pay attention to the Cautions and Warnings.

- (4) Do your (W) Preventive Maintenance weekly.

- (5) Do your (M) Preventive Maintenance once a month.

- b. Organizational maintenance personnel shall perform the preventive maintenance checks and services shown in Table 2-E-2.

- (1) Do the (Q) checks and services once every three months.

- (2) Do the (S) checks and services twice each year, or once every six months.

- (3) Do the (A) checks and services once each year.
- (4) Do the (B) checks and services once every two years.
- (5) Do the (H) checks and services at the hour interval listed.
- (6) Do the (MI) checks and services when the mileage of the vehicle reaches the amount listed.

**WARNING**

**Drycleaning solvent, SD-2 used to clean parts, is potentially dangerous to personnel and property. Do not use near open flame or excessive heat. Flash point of solvent is 1380.**

c. Make cleanup a part of your preventive maintenance. Dirt, grease, oil, and debris may cover up a serious problem. Wipe off excess grease and spilled oil.. Use drycleaning solvent (SD-2) to clean metal surfaces.. Use soap and water when you clean rubber or plastic material.

d. Watch for and correct anything that might cause a problem with the equipment. Some things you should watch for are:

- (1) Bolts, nuts, and screws that are loose, missing, bent, or broken.
- (2) Welds that are bad or broken.
- (3) Electric wires and connectors that are bare, broken, or loose.
- (4) Hoses and fluid lines that leak, or show signs of damage or wear.

e. You should know how fluid leaks affect the status of your equipment. Learn and be familiar with the following definitions of the types/ classes of leakage. Remember - when in doubt, notify your supervisor!

Leakage Definitions for PMCS are:

Class I Seepage of fluid (indicated by wetness or discoloration not great enough to form drops.

Class II Leakage of fluid great enough to form drops but not enough to cause drops to drip from the item being checked/inspected.

Class III Leakage of fluid great enough to form drops that fall from the item being checked/inspected.

**CAUTION**

Equipment operation is allowable with minor leakage (class I or II). Of course consideration must be given to the fluid capacity in the item/system being checked/inspected. When in doubt, notify your supervisor.

Class III leaks should be corrected before releasing equipment for operation.

- f. If the crane doesn't work properly and you can't see what is wrong, refer to troubleshooting instructions.



Table 2-E-1. Operator/Crew Preventive Maintenance Checks and Services  
CRANE

OPERATOR/CREW PREVENTIVE MAINTENANCE CHECKS AND SERVICES							
B - BEFORE      D - DURING      A - AFTER      W - WEEKLY      M - MONTHLY							
ITEM NO	INTERVAL					ITEM TO BE INSPECTED PROCEDURE:CHECK FOR AND HAVE REPAIRED, FILLED, OR ADJUSTED AS NEEDED	EQUIPMENT IS NOT READY/AVAILABLE IF:
	B	D	A	W	M		
						<p align="center"><b>NOTE</b></p> <p>Perform weekly as well as before PMCS if: A. You are the assigned operator, but have not operated. the crane since the last weekly. B. You are operating the crane for the first time: 1. Make the following walk around checks: (Exterior of vehicle)</p> <p>* a. Check for evidence of leakage (oil, hydraulic fluid) on or under the crane. '  * b. Visually check for loose, missing or damaged parts.</p> <p>Instruments Check for normal operating readings for the instruments as follows:</p> <p>a. Engine Oil Pressure .....40 - 60 PSI b. Engine Water Temperature ..... 160° - 185°F c. Voltmeter..... 12.8 - 13.. V d. Hydraulic Oil Temperature ..... 700 - 200 F</p> <p>3. Control Levels and Pedals Check for proper operation</p> <p>4. Hoisting Cables Inspect for stretch, wear and damage</p> <p align="center"><b>3-2-46</b></p>	<p>Class III leakage is evident.</p> <p>Pressure/temperature gages not within ranges specified</p> <p>Improper operation</p> <p>Six broken wires in one rope lay, or three wires in one strand of one rope lay, or four percent of total number of wires in rope, in length of one rope lays (TB 43-0142)</p>

Table 2-E-1, Operator/Crew Preventive Maintenance Checks and Services --CONTINUED  
CRANE

OPERATOR/CREW PREVENTIVE MAINTENANCE CHECKS AND SERVICES							
B - BEFORE      D - DURING      A - AFTER      W - WEEKLY      M - MONTHLY							
ITEM NO	INTERVAL					ITEM TO BE INSPECTED PROCEDURE:CHECK FOR AND HAVE REPAIRED, FILLED, OR ADJUSTED AS NEEDED	EQUIPMENT IS NOT READY/AVAILABLE IF:
	B	D	A	W	M		
5.	*					Boom Assembly Inspect for cracks, bends and damage. Check boom point for cracks and damaged sheaves.	Bent or broken boom.
6.	*					Hook Block Inspect for cracks and damaged sheaves.	Cracked or deformed sheaves.
7.				•		Hydraulic Fluid Reservoir Add fluid to full mark on dipstick.	
<b>3-2-47</b>							

Table 2-E-1. Operator/Crew Preventive Maintenance Checks and Services --CONTINUED  
CARRIER

OPERATOR/CREW PREVENTIVE MAINTENANCE CHECKS AND SERVICES							
B - BEFORE      D - DURING      A - AFTER      W - WEEKLY      M - MONTHLY							
ITEM NO	INTERVAL					ITEM TO BE INSPECTED PROCEDURE:CHECK FOR AND HAVE REPAIRED, FILLED, OR ADJUSTED AS NEEDED	EQUIPMENT IS NOT READY/AVAILABLE IF:
	B	D	A	W	M		
						<p style="text-align: center;"><b>NOTE</b></p> <p>Perform weekly as well as before PMCS's if: A. You are the assigned operator, but have not operated carrier since the last weekly. B. You are operating the carrier for the first time.</p>	
1.	*			*		<p>Make the following walk around checks: (Exterior of vehicle)</p> <p>a. Check for evidence of leakage (oil, fuel, hydraulic fluid or coolant) on or under the carrier.</p> <p>b. Check tires for damage or low pressure. (Correct pressure is 75 PSI).</p> <p>c. Check for loose, missing or damaged parts.</p>	Class III leakage is evident: (No fuel leakage allowed)
2.	*					<p>Radiator Check coolant level. Fill to overflow.</p>	Class III leakage is evident.
3.		Belts		*		<p>Inspect fan, alternator, air compressor, steering pump, and water pump belts for frayed or deteriorated condition.</p>	Belt is missing or broken.
4.		Batteries		*		<p>Check level of electrolyte. If low, fill with clean water (distilled if possible) to the split ring. In freezing weather, run engine at least 15 minutes after adding water. (See TM</p>	
<b>3-2-48</b>							

Table 2-E-1. Operator/Crew Preventive Maintenance Checks and Services-CONTINUED  
CARRIER

OPERATOR/CREW PREVENTIVE MAINTENANCE CHECKS AND SERVICES							
B - BEFORE      D - DURING      A - AFTER      W - WEEKLY      M - MONTHLY							
ITEM NO	INTERVAL					ITEM TO BE INSPECTED PROCEDURE:CHECK FOR AND HAVE REPAIRED, FILLED, OR ADJUSTED AS NEEDED	EQUIPMENT IS NOT READY/AVAILABLE IF:
	B	D	A	W	M		
5.		*				Instruments a. Engine Water Temperature ..... 1600 - 1850F b. Engine Oil Pressure ..... 40 - 60 PSI c. Voltmeter..... 12.8 - 13.8V d. Air Pressure ..... 105 - 120 PSI e. Tachometer..... 2600 RPM	Pressure/temperature gages not within proper range.
6.		*				Lights Check for proper operation.	
7.		*				Brakes Check for proper operation.	Stopping ability impaired.
8.		*			*	Windshield Wiper a. Inspect blade and arm for damage and deterioration. b. Check for proper operation.	
9.	*	*				Outriggers a. Check for damage. b. Check for proper operation.	Inoperative or class III leakage.
10.				*		Air Reservoir a. Check safety valve for proper operation. b. Drain water and sediment.	Safety valve inoperative.
11.	*					Engine Check oil level, add oil to full mark on dipstick.	

Table 2-E-1. Operator/Crew Preventive Maintenance Checks and Services --CONTINUED  
CARRIER

OPERATOR/CREW PREVENTIVE MAINTENANCE CHECKS AND SERVICES							
B - BEFORE      D - DURING      A - AFTER      W - WEEKLY      M - MONTHLY							
ITEM NO	INTERVAL					ITEM TO BE INSPECTED PROCEDURE:CHECK FOR AND HAVE REPAIRED, FILLED, OR ADJUSTED AS NEEDED	EQUIPMENT IS NOT READY/AVAILABLE IF:
	B	D	A	W	M		
12.		*				Controls Check each control for proper operation.	Improper operation.
13.				•		Air Cleaner • Check for cleanliness, replace element if excessively dirty.  3-2-50	

Table Z-E-2. ORGANIZATIONAL PREVENTIVE MAINTENANCE CHECKS AND SERVICES  
CRANE

ITEM NO	INTERVAL						ITEM TO BE INSPECTED PROCEDURE:CHECK FOR AND HAVE REPAIRED, FILLED, OR ADJUSTED AS NEEDED	EQUIPMENT IS NOT READY/AVAILABLE IF:
	Q	S	A	B	H	NI		
1.					200		<p style="text-align: center;"><b>NOTE</b></p> <p style="text-align: center;"><b>Perform operator/crew PMCS prior to or in conjunction with organizational PMCS.</b></p> <p>Torque mounting bolts on slewing ring to 550 pounds foot after each 200 hours of operation. Hoses and Tubing</p> <p style="text-align: center;"><b>3-2-51</b></p>	
2.						<ul style="list-style-type: none"> <li>• Check for leaks, damage and deterioration.</li> </ul>		

Table Z-E-2. ORGANIZATIONAL PREVENTIVE MAINTENANCE CHECKS AND SERVICES  
CRANE

ITEM NO	INTERVAL						ITEM TO BE INSPECTED PROCEDURE:CHECK FOR AND HAVE REPAIRED, FILLED, OR ADJUSTED AS NEEDED	EQUIPMENT IS NOT READY/AVAILABLE IF:
	Q	S	A	B	H	NI		
1.	*						<p style="text-align: center;"><b>NOTE</b></p> <p><b>Perform operator/crew PMCS prior to or in conjunction with organizational PMCS.</b></p> <p>Cooling System</p> <ul style="list-style-type: none"> <li>a. Inspect hoses and lines for damage, leaks, restrictions, and deterioration.</li> <li>b. Use hydrometer to measure coolant system freezing point. Add antifreeze as required to protect coolant system to lowest expected ambient temperature.</li> <li>c. Inspect radiator for leaks and cleanliness.</li> </ul> <p>Fuel System</p> <ul style="list-style-type: none"> <li>a. Check for leaks.</li> <li>b. Change filters after 160 engine hours..</li> <li>c. Drain sediment and water from fuel tank.</li> </ul> <p>Air Cleaner</p> <p>Disassemble, clean, replace filter and reassemble.</p> <p>Brakes</p> <p>Check for proper operation and adjust or replace linings as required.</p> <p>Engine Clutch</p> <ul style="list-style-type: none"> <li>a. Check for proper operation, adjust if required.</li> <li>b. Check master cylinder hydraulic fluid level</li> </ul> <p>Engine</p> <ul style="list-style-type: none"> <li>a. Change oil and filters after 160 engine hours.</li> <li>b. Adjust or replace belts as required.</li> <li>c. Clean crankcase breather.</li> </ul> <ul style="list-style-type: none"> <li>• d. Inspect and clean blower screen.</li> </ul> <p style="text-align: center;"><b>3-2-52</b></p>	
2.	*				160			
3.	*							
4.	*							
5.	*							
6.	*				160			

Table 2-E-2. ORGANIZATIONAL PREVENTIVE MAINTENANCE CHECKS AND SERVICES -CONTINUED  
CARRIER

ITEM NO	INTERVAL						ITEM TO BE INSPECTED PROCEDURE:CHECK FOR AND HAVE REPAIRED, FILLED, OR ADJUSTED AS NEEDED	EQUIPMENT IS NOT READY/AVAILABLE IF:
	Q	S	A	B	H	NI		
7.	*						Batteries Check for corrosion and damage.	
8.	*						Air System Check for leaks damage and deterioration.	
9.	*						Power Steering/Outrigger Filter Inspect and clean.	
10.	*						Hydraulic Tank Clean breather.  <b>3-2-53/(3-2-54 (blank))</b>	



### Section III REPAIR PARTS SUPPLY

#### 3-1. General:

- a. The basic policies and procedures in AR 710-2 and AR 725-5n are generally applicable to repair parts management for CCE items.
- b. Manufacturer's parts manuals are furnished with CCE items instead of Department of the Army Repair Parts and Special Tool List (RPSTL).
- c. National Stock Numbers (NSN's) are initially assigned only to PLL/ ASL parts and major assemblies, i.e., engines, transmissions, etc. Additional NSNs are assigned by the supply support activities as demands warrant.
- d. Automated Processing (AUTODIN) of Federal Supply Code for Manufacturers (FSCM) part number requisitions, without edit for matching NSNs and exception data, is authorized.
- e. Proper use of Direct Support Systems (DSS) project codes and weapon systems designator codes on parts requisitions is essential.
- f. Repair parts are available from commercial sources for CONUS units and may be purchased locally in accordance with AR 710-2 and AR 735-110.
- g. Initial Prescribed Load List (PLL) and Authorized Stock List (ASL) will be distributed by Tank-Automotive Materiel Readiness Command (TARCOM), DRSTA-MVB.

3-2. Prescribed Load List (PLL): The PLL distributed by TARCOM is an estimated 15 days supply recommended for initial stockage at organizational maintenance. Management of PLL items will be governed by the provisions of AR 710-2 and local command procedures. An initial stock of PLL parts will be shipped to OCONUS units before shipment of the end item. Selection of PLL parts for shipment to OCONUS units is based upon the receiving command's recommendations after their review of the TARCOM prepared list. Organizations and activities in CONUS will establish PLL stocks through normal requisitioning process.

3-3. Authorized Stockage List (ASL): The ASL distributed by TARCOM is an estimated 45 days supply of repair parts for support units and activities. An initial stock of ASL parts will be shipped to designated support units OCONUS before shipment of the end items. The parts shipped will be selected according to the recommendations of the receiving commands, after they have reviewed the initial list distributed by TARCOM. Support units and activities in CONUS will establish ASL stocks through normal requisitioning process.

#### 3-4. Requisitioning Repair Parts.

- a. Using Units/Organizations: Requisitions (DA Form 2765 Series) will be prepared according to AR 710-2 and local command directives. All requisitions will have the Weapons System Designator Code "74" (Interim Change 5-1, AR 710-2 per DA Message, DALO-SMS 091400Z Jan 78) entered in the 2nd and 3rd positions of block 18. Units in CONUS will use Project Code "BGW" in block 19. Units OCONUS will enter in block 19 Project Code "JZC", Appendix H.

b. Support Units and Activities:

(1) General: All MILSTRIP requisitions (DD Form 1348 Series) prepared for repair parts support of CCE items will include distribution and Project Codes, see Appendixes I, J and K.

(2) Distribution Code: Supply customers in CONUS will use code "F" in column 54. Customers OCONUS will use the appropriate code from Appendix P, paragraph P-3a(1) AR 725-50. Weapons System Designator Code (DA Message DALO-SMS,091400Z Jun 78) will be entered in card columns 55 and 56 of all requisitions.

(3) Project Codes: The applicable Project Code will be entered in card columns 57-59 of requisitions for NSN parts, whether CONUS or OCONUS customers. Project Code "BGW" will be used by CONUS customers when requisitioning part numbered parts. Supply customers OCONUS will use Project Code "JZC" for part numbered parts.

3-5. Submitting Requisitions:

a. Using Units and Organizations will submit DA Form 2765 Series requisitions to designated support units or activities in accordance with local procedures.

b. Support units and activities will forward MILSTRIP requisitions for NSN part through the Defense Automated Addressing System (DAAS) to the Managing Supply Support Activity. Requisitions for part numbered parts will be forwarded through DAAS to the Defense Construction Supply Center (DCSC).

NOTE: When the manufacturer's part number and Federal Supply Code for Manufacturer (FSCM) exceed the space in card columns 8 through 22 of A02/AOB requisitions, prepare an A05AOE requisition (DD Form 1348-6) and mail it to Commander, Defense Construction Supply Center, ATTN: DCSC-OSR, Columbus, OH 43215.

3-6. DA Equipment Publications:

a.	Utilization of Construction Equipment	TM5-331B	MAY 68
b.	Safe Use of Cranes, Crane Shovel, and Draglines	TM 385-101	JAN 71
c.	Procedures for Licensing Operators of Construction Equipment	TB600-2	SEP 78

APPENDIX 3-A  
 PRESCRIBED LOAD LIST (PLL)  
 AUTHORIZED STOCKAGE LIST (ASL)

END ITEM: Crane, 25 Ton, Hydraulic			MAKE: P&H		MODEL: MT250				
MFR PART NO: N/A		NSN: 3810-00-018-2021		SERIAL NUMBER RANGE E36080 TO E36199		DATE 28 MAR 78			
SMR CODE	NATIONAL STOCK NUMBER	PART NUMBER	FCSM	PART DESCRIPTION	U/M	QTY OF PARTS REQ'D FOR NO. OF END ITEMS			
						PLL	ASL		
							1-5	1-5	6-20
PAOZZA	4330-00-277-3274	28605A	90005	Cartridge, Filter: Hydraulic Steer	EA	1	3	5	
PAOZZA	2940-00-836-9668	923070	62983	Cartridge, Ftlter: Hydraulic Oil	EA	2	6	10	
PAOZZA	3030-00-088-4643	5133177	72582	Belt Set: Alternator	SE	1	1	2	
PAOZZA	3030-00-982-1208	5134212	72582	Belt Set: Fan	SE	1	1	2	
PAOZZA	2940-00-580-6283	PF132	80659	Element, Filter: Engine Oil	EA	2	6	10	
PAOZZA	2910-00-781-1354	6438840	72582	Element, Filter: Fuel Secondary	EA	1	3	5	
PAOZZA	2910-01-025-6853	6438837	72582	Element: Fuel Strainer Primary	EA	1	3	5	
PAOZZA	6330-00-792-9026	5147994	72582	Gasket: Rocker Arm Cover	EA		6	10	
PAOZZA	2940-00-842-1878	P32	21585	Element: Air Cleaner	EA		2	4	
PAOZZA	6240-00-752-2424	6013	08108	Lamp, Incandescent: Flood Light	EA		3	5	
PAOZZA	6240-00-155-8717	67	08108	Lamp, Incandescent: Clearance	EA		3	5	
PAOZZA	6240J00-295-1184	1034	08108	Lamp Incandescent: Directional	EA		3	5	
PAOZZA	6240-00-889-1799	1157	08108	Lamp, Incandescent: Stop & Tail	EA		3	5	
PAOZZA	6220-00-364-1592	56Z117D1	27315	Headlight, RH	EA		2	4	
PAOZZA	6220-00-364-1593	56Z117D2	27315	Headlight, RH	EA		2	4	
PAOZZA	2910-00-315-9911	5229350	71934	Injector Assy: C50	EA		3	5	
			<b>3-3-3/(3-3-4(blank))</b>						

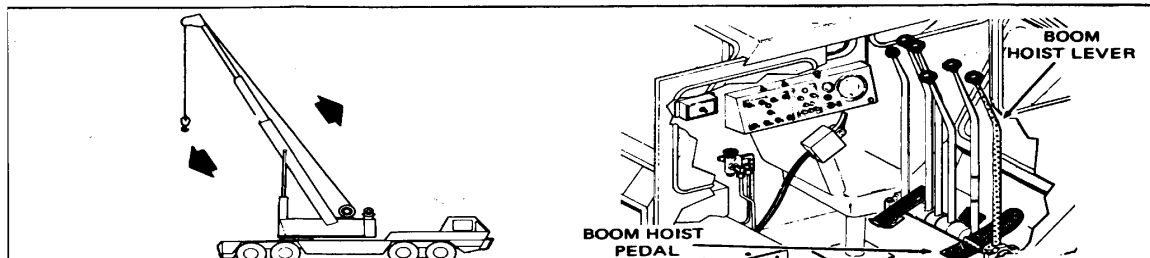

**SETTING BOOM ANGLE.** Position the boom at the proper angle for the load and working conditions. Refer to the rating plate for proper angle. Pull the boom hoist lever (or pedal) back to raise the boom. Push the boom hoist lever (or pedal) forward to lower the boom. Be sure to pay out line from the main and/or auxiliary winch, as required, to prevent the hook block(s) from coming in contact with the boom point.

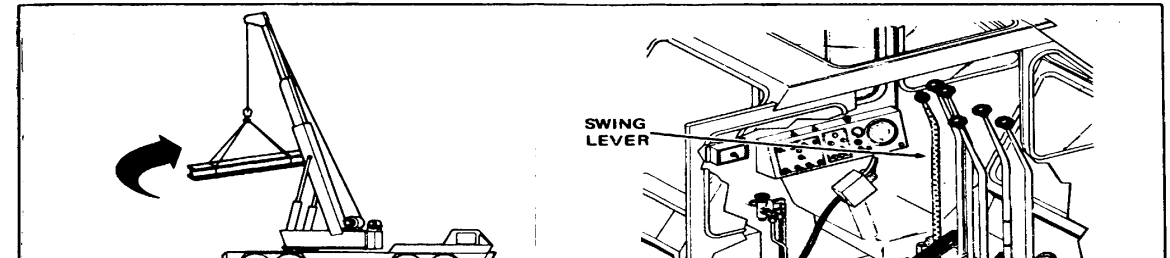

**SWINGING.** Push the swing lever forward to swing the upper to the left. Pull the swing lever back to swing to the right. Depress the swing brake pedal to stop and hold the upper.

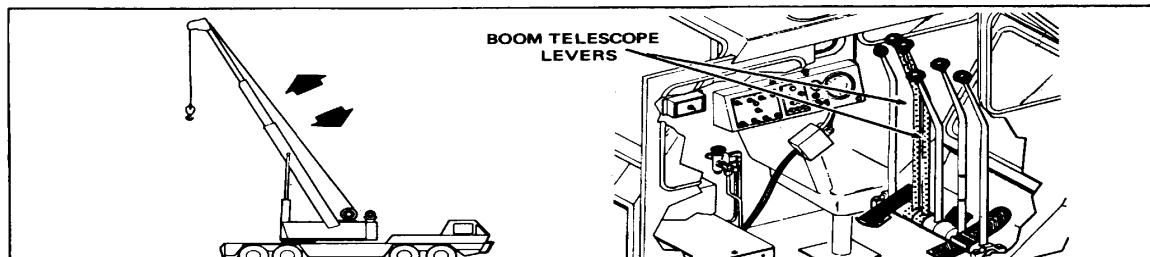

**SETTING BOOM LENGTH.** Push the boom telescope levers forward to extend the boom sections. Pull the boom telescope levers back to retract the boom sections. Be sure the boom sections are extended equally, and do not extend the boom further than required to perform the operation. Be sure to pay out line from the main and/or auxiliary winch, as required, to prevent the hook block(s) from coming in contact with the boom point.

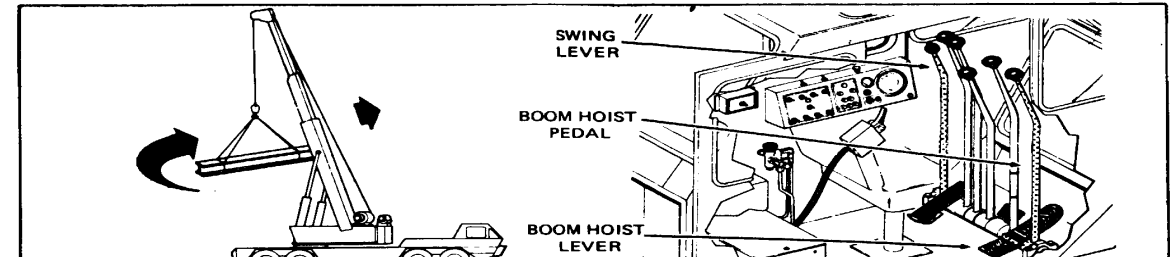

**SPOTTING THE LOAD.** Spotting the load requires accurate control of the boom hoist and swing movements. It takes practice to locate the load at the exact spot without hunting or overshooting. Raise or lower the boom with the boom hoist lever as necessary to accurately locate the load. Never extend the boom out so far that rated load is exceeded. See the rating plate.

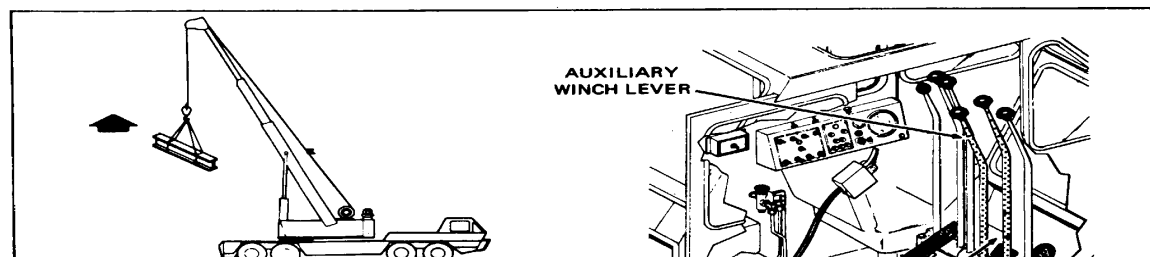

**LIFTING THE LOAD (HOISTING).** Push the main (or auxiliary) winch lever forward to lower the hook block. Attach the load to the hook block, then pull the main (or auxiliary) winch lever back to raise the load.

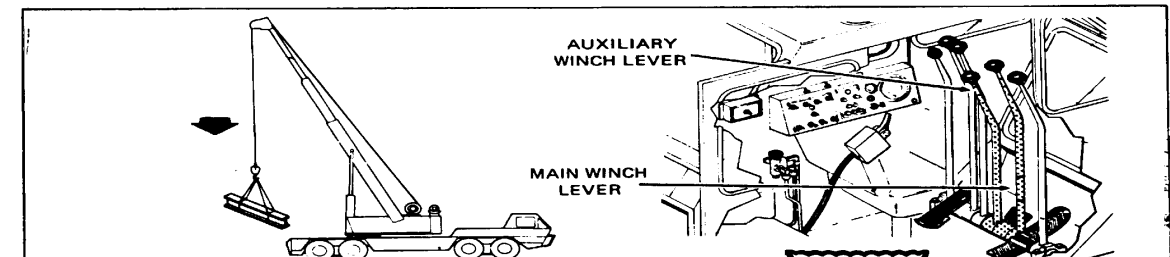

**LOWERING THE LOAD.** The load can be lowered by two methods. Push the main (or auxiliary) winch lever forward, part way, to power down the load. Light loads can be free-fallen by pushing the lever to the extreme forward position.

**CAUTION**  
Return the control lever to the power lowering position slowly to avoid shock loading the winch and winch line.

Figure 2-9. Crane Operating Cycle - P&H Winch

SECTION II

CONTROLS AND OPERATIONS

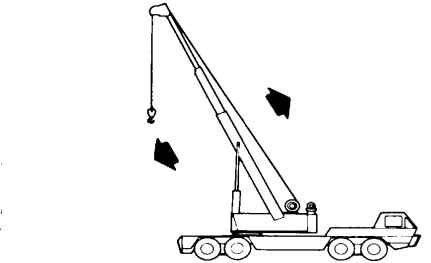
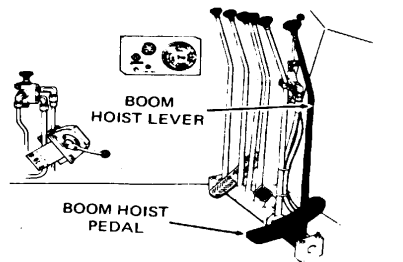
**SETTING BOOM ANGLE.** Position the boom at the proper angle for the load and working conditions. Refer to the rating plate for proper angle. Pull the boom hoist lever (or pedal) back to raise the boom. Push the boom hoist lever (or pedal) forward to lower the boom. Be sure to pay out line from the main and/or auxiliary winch, as required, to prevent the hook block(s) from coming in contact with the boom point.

**SWINGING.** Push the swing lever forward to swing the upper to the left. Pull the swing lever back to swing to the right. Depress the swing brake pedal to stop and hold the upper.

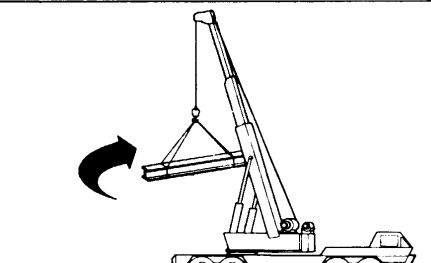
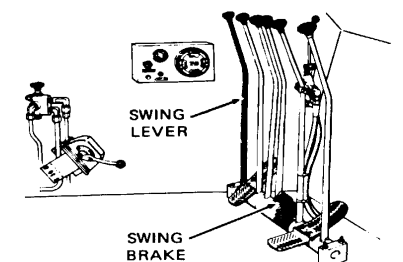
**SETTING BOOM LENGTH.** Push the boom telescope levers forward to extend the boom sections. Pull the boom telescope levers back to retract the boom sections. Be sure the boom sections are extended equally, and do not extend the boom further than required to perform the operation. Be sure to pay out line from the main and/or auxiliary winch, as required, to prevent the hook block(s) from coming in contact with the boom point.

**SPOTTING THE LOAD.** Spotting the load requires accurate control of the boom hoist and swing movements. It takes practice to locate the load at the exact spot without hunting or overshooting. Raise or lower the boom with the boom hoist lever as necessary to accurately locate the load. Never extend the boom out so far that rated load is exceeded. See the rating plate.

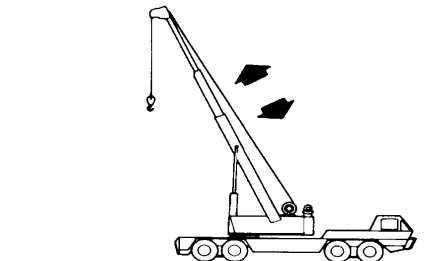
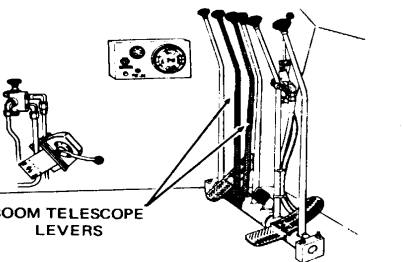
**LIFTING THE LOAD (HOISTING).** Push the main (or auxiliary) winch lever forward to lower the hook block. Attach the load to the hook block, then pull the main (or auxiliary) winch lever back to raise the load.

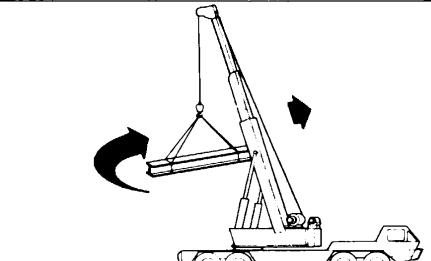
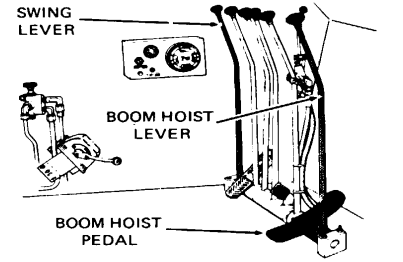
**LOWERING THE LOAD.** The load can be lowered by two methods. Push the main (or auxiliary) winch lever forward to power down the load. Light loads can be free-falled by slowly squeezing the free-fall lever toward the main winch lever.

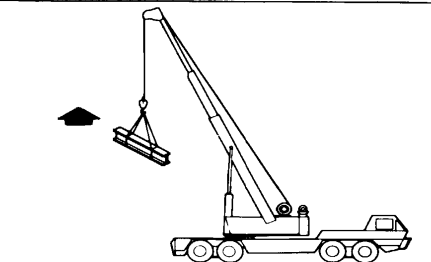
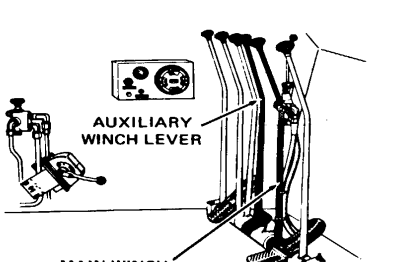
**CAUTION**

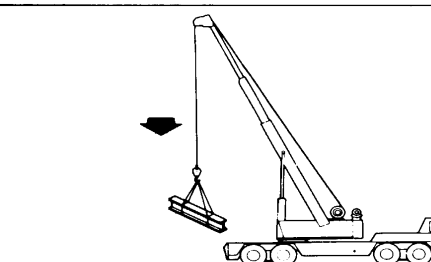
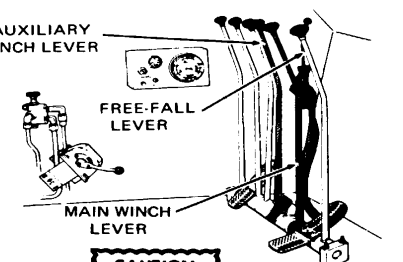
Release the free-fall control lever slowly to avoid shock loading of the main winch and main winch line.

Figure 2-10. Crane Operating Cycle - Gearmatic Winch

SECTION III  
UPPER LUBRICATION CHART

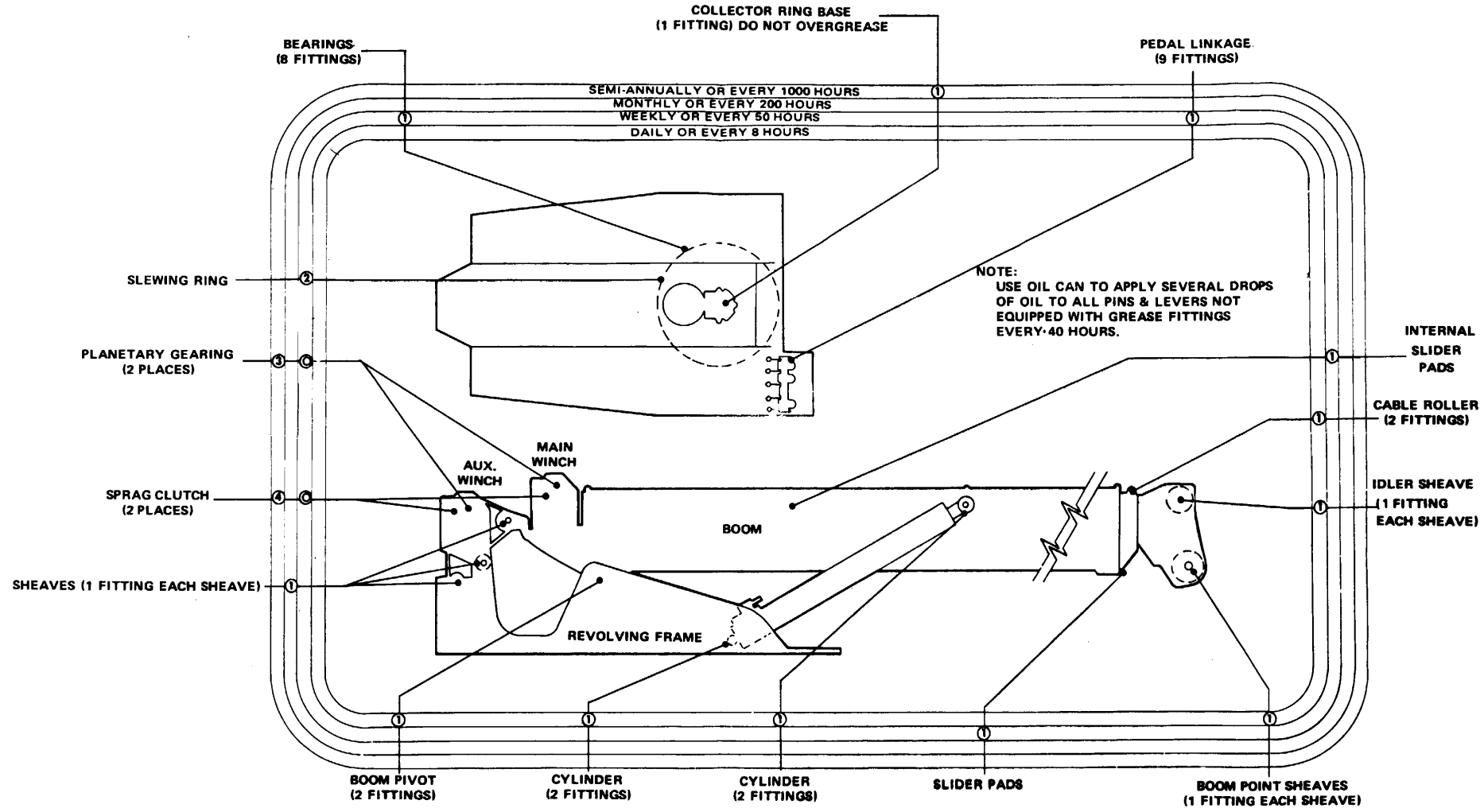

LEGEND  
 ◎ - CHECK FREQUENCY  
 ○ - SERVICE FREQUENCY

LUBRICATION RECOMMENDATIONS						
NO.	LUBRICANT	SYMBOL	P&H NO.	ABOVE 40°F (4°C)	BELOW 40°F (4°C)	
1	MULTI PURPOSE GREASE	MPG		472 C	472 B	
2	OPEN GEAR LUBRICANT	GL	484	ALL SEASONS		
3	GEAR OIL	GO		497C	497 B	
4	POWER TRANSMISSION & GEAR OIL	ATF	494	ALL SEASONS		

Figure 3-1. Upper lubrication Chart (10J827)

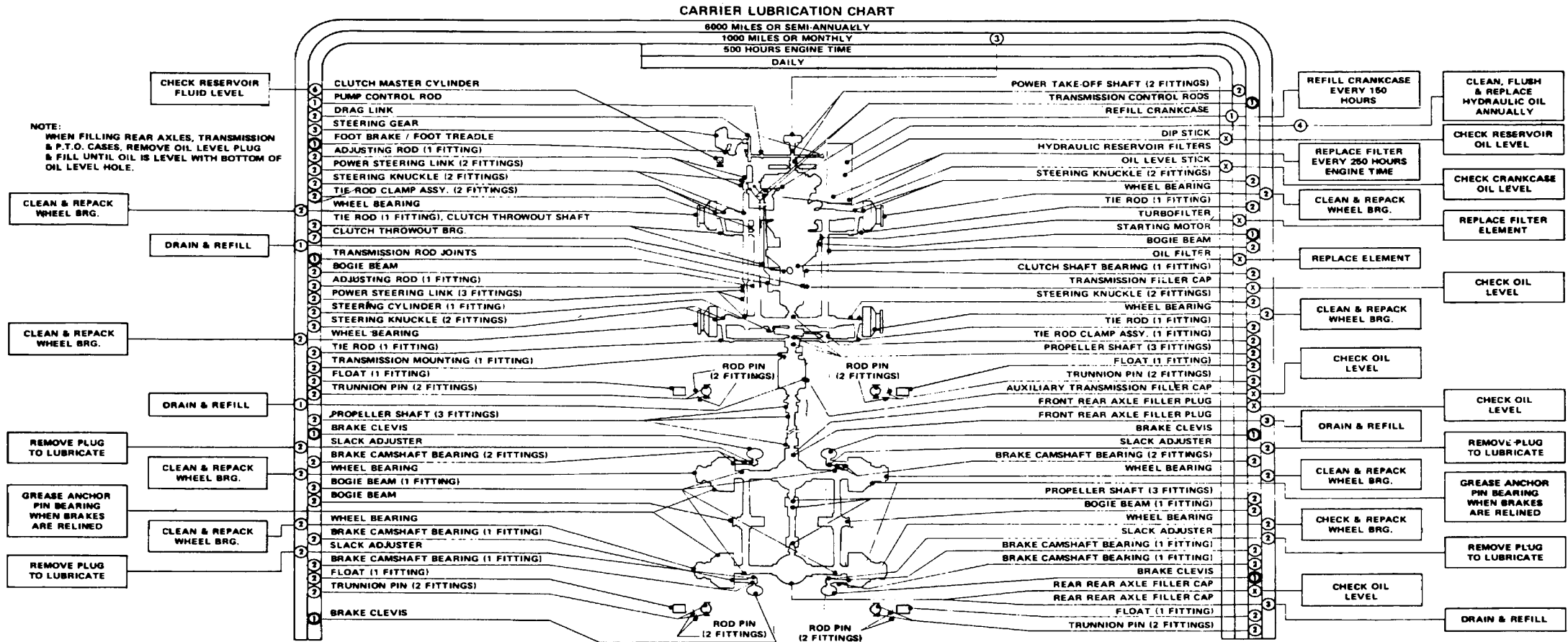

REF. NO.	LUBRICANT	P&H NO.	SEE CHART B
1	MOTOR OIL	451	SEE CHART B
2	MULTI PURPOSE GREASE	472	SEE LUBE SPEC
3	GEAR OIL (EXTREME PRESSURE)	497	BELOW +10 F (+12 C) SAE 80 +32 F to 90 F (0 C to 32 C) SAE 90 ABOVE +90 F (32 C) SAE 140
4	HYDRAULIC OIL	484	SEE LUBE SPEC
5	HEAVY DUTY OIL	486	A.G.M.A. NO. 4
6	USE OIL CAN	451	SEE 1 ABOVE
7	BRAKE FLUID	492	ALL SEASON
8	HIGH TEMP GREASE	476	N.L.G.I. NO. 2

Motor Oil			
P&H 451C, MIL L 2104B, SAE 30 is recommended for year round use when cold starting can be accomplished. Consult Engine Manufacturer for further information.			
DETROIT DIESEL 6V-53N	Total Cooling System	32.5 QTS. (30.75 l)	
AIR TEMP.	P&H NO.	SAE NO.	
Below +10 F (+12 C)	451A	10W	
+10 F to +32 F (+12 F to 0 C)	451B	20 20W	
+32 F to +90 F (0 C to +32 C)	451C	30	
Above +90 F (+32 C)	451E	50	

OIL CAPACITY	U.S. QTS.	OIL CAPACITY	U.S. QTS.
TRANSMISSION-SPICER 6352	8.5 (8.0 l)	INTER-AXLE DIFFERENTIAL	1 (0.9 l)
AUX. TRANS.-SPICER RB341E	6.5 (6.2 l)	POWER TAKE OFF - COTTA	3.5 (3.3 l)
REAR AXLES S.S. H.D.		STEERING GEAR	2.5 (2.4 l)
FRONT	16 (15.1 l)	POWER STEERING	SEE RESERVOIR
REAR	14 (13.2 l)	HYDRAULIC RESERVOIR	800 (757 l)

A 107

Figure 3-2. Carrier Lubrication Chart (105J828-C)

1-3-11/(1-3-12 (blank))

By Order of the Secretary of the Army

Official:

J. C. PENNINGTON  
*Major General, United States Army*  
*The Adjutant General*

E. C. MEYER  
*General, United States Army*  
*Chief of Staff*

Distribution:

To be distributed in accordance with DA Form 12-25B, operator maintenance requirements for cranes: truck mounted.

\*U.S. GOVERNMENT PRINTING OFFICE: 1996 - 406-421/43255





# THE METRIC SYSTEM AND EQUIVALENTS

## WEIGHT MEASURE

1 Centimeter = 10 Millimeters = 0.01 Meters = 0.3937 Inches  
 1 Meter = 100 Centimeters = 1000 Millimeters = 39.37 Inches  
 1 Kilometer = 1000 Meters = 0.621 Miles

## WEIGHTS

1 Gram = 0.001 Kilograms = 1000 Milligrams = 0.035 Ounces  
 1 Kilogram = 1000 Grams = 2.2 lb.  
 1 Metric Ton = 1000 Kilograms = 1 Megagram = 1.1 Short Tons

## LIQUID MEASURE

1 Milliliter = 0.001 Liters = 0.0338 Fluid Ounces  
 1 Liter = 1000 Milliliters = 33.82 Fluid Ounces

## SQUARE MEASURE

1 Sq. Centimeter = 100 Sq. Millimeters = 0.155 Sq. Inches  
 1 Sq. Meter = 10,000 Sq. Centimeters = 10.76 Sq. Feet  
 1 Sq. Kilometer = 1,000,000 Sq. Meters = 0.386 Sq. Miles

## CUBIC MEASURE

1 Cu. Centimeter = 1000 Cu. Millimeters = 0.06 Cu. Inches  
 1 Cu. Meter = 1,000,000 Cu. Centimeters = 35.31 Cu. Feet

## TEMPERATURE

$5/9(^{\circ}\text{F} - 32) = ^{\circ}\text{C}$   
 212° Fahrenheit is equivalent to 100° Celsius  
 90° Fahrenheit is equivalent to 32.2° Celsius  
 32° Fahrenheit is equivalent to 0° Celsius  
 $9/5^{\circ}\text{C} + 32 = ^{\circ}\text{F}$

## APPROXIMATE CONVERSION FACTORS

TO CHANGE	TO	MULTIPLY BY
Inches	Centimeters	2.540
Feet	Meters	0.305
Yards	Meters	0.914
Miles	Kilometers	1.609
Square Inches	Square Centimeters	6.451
Square Feet	Square Meters	0.093
Square Yards	Square Meters	0.836
Square Miles	Square Kilometers	2.590
Acres	Square Hectometers	0.405
Cubic Feet	Cubic Meters	0.028
Cubic Yards	Cubic Meters	0.765
Fluid Ounces	Milliliters	29.573
its	Liters	0.473
arts	Liters	0.946
allons	Liters	3.785
Ounces	Grams	28.349
Pounds	Kilograms	0.454
Short Tons	Metric Tons	0.907
Pound-Feet	Newton-Meters	1.356
Pounds per Square Inch	Kilopascals	6.895
Miles per Gallon	Kilometers per Liter	0.425
Miles per Hour	Kilometers per Hour	1.609

TO CHANGE	TO	MULTIPLY BY
Centimeters	Inches	0.394
Meters	Feet	3.280
Meters	Yards	1.094
Kilometers	Miles	0.621
Square Centimeters	Square Inches	0.155
Square Meters	Square Feet	10.764
Square Meters	Square Yards	1.196
Square Kilometers	Square Miles	0.386
Square Hectometers	Acres	2.471
Cubic Meters	Cubic Feet	35.315
Cubic Meters	Cubic Yards	1.308
Milliliters	Fluid Ounces	0.034
Liters	Pints	2.113
Liters	Quarts	1.057
ers	Gallons	0.264
ms	Ounces	0.035
ograms	Pounds	2.205
Metric Tons	Short Tons	1.102
Newton-Meters	Pounds-Feet	0.738
Kilopascals	Pounds per Square Inch	0.145
ometers per Liter	Miles per Gallon	2.354
ometers per Hour	Miles per Hour	0.621

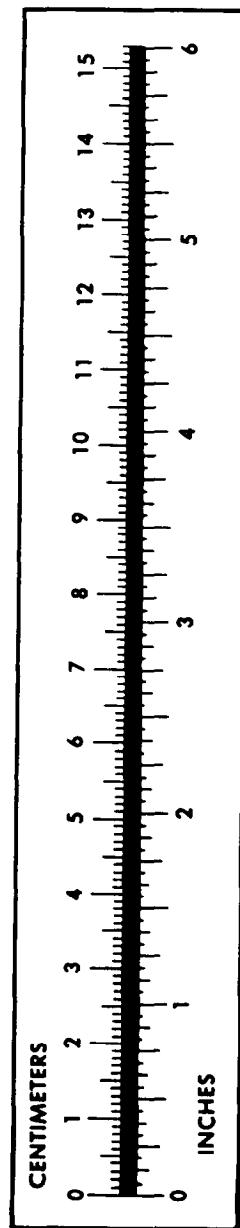

**PIN: 046755-003**